

Stenographer Grade C and D Examination 2023

Roll Number	
Candidate Name	
Venue Name	ARYA MAHILA PG COLLEGE
Exam Date	12/10/2023
Exam Time	9:00 AM - 11:00 AM
Subject	Stenographer Grade C and D Examination 2023

Section : General Intelligence and Reasoning

Q.1 सलमान अपने कार्यालय से चलना शुरू करता है और दक्षिण की ओर 29 km ड्राइव करता है। फिर वह दाएं मुड़ता है और 16 km ड्राइव करता है, फिर से वह दाएं मुड़ता है और 29 km ड्राइव करता है। अंत में वह दाएं मुड़ता है और 13 km ड्राइव करता है। वह एक सीधी रेखा में अपने शुरुआती बिंदु से कितनी दूरी पर है?

- Ans 1. 16 km
 2. 3 km
 3. 13 km
 4. 29 km

Question ID : 264330132111
Option 1 ID : 264330517542
Option 2 ID : 264330517540
Option 3 ID : 264330517539
Option 4 ID : 264330517541
Status : Answered
Chosen Option : 2

Q.2 निम्नलिखित चार अक्षर-समूहों में से तीन किसी निश्चित तरीके से आपस में संगत हैं जबकि कोई एक उनसे असंगत है। असंगत अक्षर-समूह का चयन कीजिए।

- Ans 1. KNS
 2. QTY
 3. BEJ
 4. GLP

Question ID : 26433058005
Option 1 ID : 264330227006
Option 2 ID : 264330227007
Option 3 ID : 264330227004
Option 4 ID : 264330227005
Status : Answered
Chosen Option : 4

Q.3 निम्नांकित श्रृंखला में पैटर्न को जारी रखने के लिए प्रश्नचिह्न (?) को किस आकृति द्वारा प्रतिस्थापित किया जाना चाहिए?

♡	3	Z	7	T	3	B	7	Z	0	T	7	
	B		♡			3			B			?
7	T	0	B	0	Z	0	T	♡	3	♡	Z	

Ans

✗ 1.

7	Z	B
	0	
T	3	♡

✓ 2.

3	0	Z
	7	
♡	T	B

✗ 3.

3	♡	0
	T	
Z	B	7

✗ 4.

T	♡	Z
	7	
0	3	B

Question ID : 264330129597

Option 1 ID : 264330507755

Option 2 ID : 264330507754

Option 3 ID : 264330507756

Option 4 ID : 264330507757

Status : Answered

Chosen Option : 2

Q.4 बिंदु A, बिंदु B से 30 m पूर्व में है। बिंदु C, बिंदु A से 43 m दक्षिण में है। बिंदु C, बिंदु D से 45 m पूर्व में है। बिंदु E, बिंदु D से 14 m दक्षिण में है। बिंदु F, बिंदु E से 35 m पूर्व में है। बिंदु F के सापेक्ष बिंदु B किस दिशा में है?

Ans

✗ 1. पश्चिम

✗ 2. उत्तर-पूर्व

✗ 3. दक्षिण-पश्चिम

✓ 4. उत्तर-पश्चिम

Question ID : 264330131628

Option 1 ID : 264330515614

Option 2 ID : 264330515612

Option 3 ID : 264330515613

Option 4 ID : 264330515611

Status : Answered

Chosen Option : 4

Q.5 दो कथनों के बाद दो निष्कर्ष I और II दिए गए हैं। कथनों को सत्य मानते हुए, भले ही वे सामान्य रूप से ज्ञात तथ्यों से भिन्न प्रतीत होते हों, निर्णय लीजिए कि कौन सा/से निष्कर्ष कथनों का तार्किक रूप से अनुसरण करता/करते है/हैं।

कथन:

कुछ कंबल, रजाई हैं।

कुछ रजाई, चादर हैं।

निष्कर्ष:

I. सभी रजाई, कंबल हैं।

II. सभी कंबल, चादर हैं।

Ans 1. निष्कर्ष I और II दोनों अनुसरण करते हैं

2. केवल निष्कर्ष II अनुसरण करता है

3. केवल निष्कर्ष I अनुसरण करता है

4. न तो निष्कर्ष I अनुसरण करता है और न ही II अनुसरण करता है

Question ID : 264330144954

Option 1 ID : 264330568073

Option 2 ID : 264330568072

Option 3 ID : 264330568071

Option 4 ID : 264330568074

Status : Answered

Chosen Option : 4

Q.6 Select the option that is related to the third word in the same way as the second word is related to the first word.

(The words must be considered as meaningful English words and must not be related to each other based on the number of letters/number of consonants/vowels in the word)

Sack : Jute :: Basket : ?

Ans 1. Bamboo

2. Rayon

3. Marble

4. Cotton

Question ID : 26433070280

Option 1 ID : 264330275596

Option 2 ID : 264330275599

Option 3 ID : 264330275598

Option 4 ID : 264330275597

Status : Answered

Chosen Option : 1

Q.7 उस समुच्चय का चयन करें जिसमें दी गई संख्याएं आपस में उसी प्रकार संबंधित हैं, जिस प्रकार प्रश्न में दिए गए समुच्चय की संख्याएं आपस में संबंधित हैं।
(नोट: संख्याओं को उसके घटक अंकों में विभाजित किए बिना, पूर्ण संख्याओं पर ही गणितीय संक्रियाएँ की जानी चाहिए। जैसे 13 - मान लीजिए 13 पर गणितीय संक्रियाएँ जैसे कि 13 में जोड़ना/घटाना/गुणा करना आदि किया जा सकता है। 13 को 1 और 3 में तोड़कर और फिर 1 और 3 पर गणितीय संक्रियाएँ करने की अनुमति नहीं है।)
(6, 12, 9)
(7, 23, 15)

- Ans 1. (20, 40, 60)
 2. (14, 12, 13)
 3. (15, 7, 8)
 4. (12, 20, 8)

Question ID : 26433087041
Option 1 ID : 264330341807
Option 2 ID : 264330341805
Option 3 ID : 264330341808
Option 4 ID : 264330341806
Status : Not Answered
Chosen Option : --

Q.8 उस विकल्प का चयन करें, जो छठी संख्या से उसी प्रकार संबंधित है, जिस प्रकार पहली संख्या दूसरी संख्या से और तीसरी संख्या चौथी संख्या से संबंधित है।
44 : 4 :: 287 : 7 :: ? : 10

- Ans 1. 570
 2. 810
 3. 890
 4. 639

Question ID : 26433087212
Option 1 ID : 264330342486
Option 2 ID : 264330342485
Option 3 ID : 264330342488
Option 4 ID : 264330342487
Status : Answered
Chosen Option : 2

Prepare 50% Faster

Q.9 दिए गए विकल्पों में से उस आकृति का चयन करें, जो निम्नलिखित शृंखला में प्रश्नचिह्न (?) को प्रतिस्थापित करेगी।

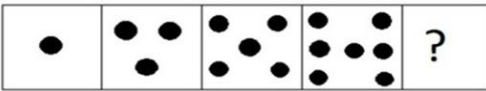

Ans

✓ 1.



✗ 2.

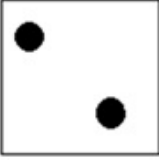

✗ 3.



✗ 4.



Question ID : 26433087163

Option 1 ID : 264330342289

Option 2 ID : 264330342291

Option 3 ID : 264330342290

Option 4 ID : 264330342292

Status : Answered

Chosen Option : 1

ixamBee

Prepare 50% Faster

Q.10 उस विकल्प का चयन करें जिसमें दी गई आकृति सन्निकित है (घुमाने की अनुमति नहीं है)।



Ans

✗ 1.

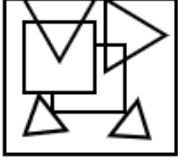

✗ 2.



✓ 3.

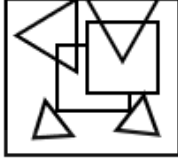

✗ 4.



Question ID : 264330132052

Option 1 ID : 264330517303

Option 2 ID : 264330517306

Option 3 ID : 264330517305

Option 4 ID : 264330517304

Status : Answered

Chosen Option : 3

Q.11 A, B, C, D, E, F और G की लंबाई भिन्न-भिन्न है। A केवल दो व्यक्तियों से लंबा है। D केवल G से छोटा है। F, A से लंबा है, लेकिन B से छोटा है। C, E से छोटा है। E से कितने लोग छोटे हैं?

Ans ✓ 1. एक

✗ 2. तीन

✗ 3. कोई नहीं

✗ 4. चार

Question ID : 264330131655

Option 1 ID : 264330515720

Option 2 ID : 264330515721

Option 3 ID : 264330515719

Option 4 ID : 264330515722

Status : Answered

Chosen Option : 1

Q.12 एक कागज को नीचे दर्शाए गए अनुसार मोड़ा और काटा जाता है। खोलने के बाद यह कैसा दिखाई देगा?

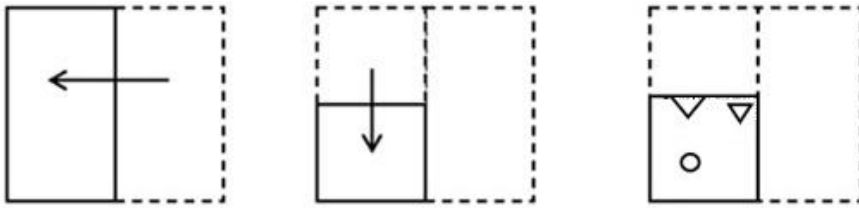

Ans

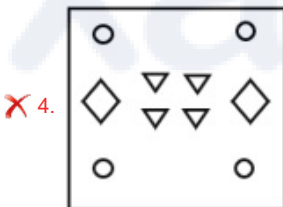
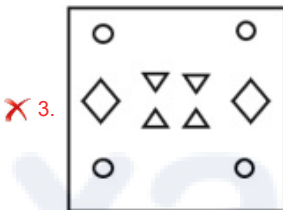
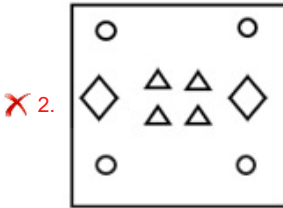
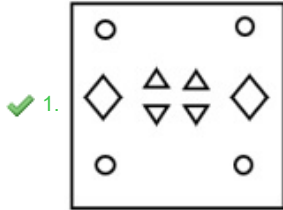

Question ID : 264330106338

Option 1 ID : 264330417654

Option 2 ID : 264330417655

Option 3 ID : 264330417656

Option 4 ID : 264330417653

Status : Answered

Chosen Option : 1

Q.13 दी गई श्रृंखला को पूरा करने के लिए कौन-सा अक्षर-समूह प्रश्नवाचक चिह्न (?) को प्रतिस्थापित करेगा?

TUWA, ?, RISI, QEQU, PAOU

Ans ✗ 1. USEO

✗ 2. UTET

✓ 3. SOUE

✗ 4. SUOE

Question ID : 264330144907

Option 1 ID : 264330567884

Option 2 ID : 264330567883

Option 3 ID : 264330567886

Option 4 ID : 264330567885

Status : Answered

Chosen Option : 3

Q.14 उस विकल्प का चयन करें जो तीसरे शब्द से उसी प्रकार संबंधित है जिस प्रकार दूसरा शब्द पहले शब्द से संबंधित है। (शब्दों को अर्थपूर्ण अंग्रेजी/हिन्दी शब्दों के रूप में माना जाना चाहिए और इन्हें शब्द में अक्षरों की संख्या/व्यंजनों की संख्या/स्वरों की संख्या के आधार पर एक-दूसरे से संबद्ध नहीं किया जाना चाहिए।)

घड़ी : समय :: कंपास : ?

- Ans
- 1. लंबाई
 - 2. दिशा
 - 3. वज़न
 - 4. हृदय दर

Question ID : 26433087284
Option 1 ID : 264330342774
Option 2 ID : 264330342776
Option 3 ID : 264330342773
Option 4 ID : 264330342775
Status : Answered
Chosen Option : 2

Q.15 निम्नलिखित चार अक्षर-समूहों में से तीन किसी निश्चित तरीके से आपस में संगत हैं जबकि कोई एक उनसे असंगत है। असंगत अक्षर-समूह का चयन कीजिए।

- Ans
- 1. EVKP
 - 2. HSNM
 - 3. GTMN
 - 4. JRPV

Question ID : 26433068790
Option 1 ID : 264330269675
Option 2 ID : 264330269673
Option 3 ID : 264330269674
Option 4 ID : 264330269672
Status : Answered
Chosen Option : 4

Q.16 निम्नलिखित में से कौन-सी संख्या दी गई श्रृंखला में प्रश्न चिह्न (?) को प्रतिस्थापित करेगी?
5, 14, 17, ?, 37

- Ans
- 1. 34
 - 2. 22
 - 3. 20
 - 4. 30

Question ID : 26433082431
Option 1 ID : 264330323559
Option 2 ID : 264330323558
Option 3 ID : 264330323557
Option 4 ID : 264330323560
Status : Answered
Chosen Option : 4

Q.17 उस विकल्प का चयन कीजिए जो नीचे दिए गए शब्दों के उस सही क्रम को दर्शाता है, जिस क्रम में वे अंग्रेजी शब्दकोश में आएं।

1. Fontina
2. Fondue
3. Fondled
4. Fondant
5. Fontanel
6. Fonder

Ans 1. 6, 4, 3, 2, 5, 1

2. 4, 6, 3, 5, 1, 2

3. 6, 3, 4, 5, 1, 2

4. 4, 6, 3, 2, 5, 1

Question ID : 264330144932

Option 1 ID : 264330567985

Option 2 ID : 264330567984

Option 3 ID : 264330567986

Option 4 ID : 264330567983

Status : Answered

Chosen Option : 4

Q.18 दो कथनों के बाद दो निष्कर्ष 1, और 2 दिए गए हैं। कथनों को सत्य मानते हुए, भले ही वे सामान्य रूप से ज्ञात तथ्यों से भिन्न प्रतीत होते हों, तय करें कि कौन-सा/से निष्कर्ष कथनों का तार्किक रूप से अनुसरण करता है/करते हैं।

कथन

1. कुछ स्तनधारी जन्तु हैं।

2. सभी जन्तु पक्षी हैं।

निष्कर्ष

1. सभी पक्षी जन्तु हैं।

2. कुछ स्तनधारी पक्षी हैं।

Ans 1. केवल निष्कर्ष 1 अनुसरण करता है।

2. केवल निष्कर्ष 2 अनुसरण करता है।

3. निष्कर्ष 1 और निष्कर्ष 2 दोनों अनुसरण करते हैं।

4. न तो निष्कर्ष 1 और न ही निष्कर्ष 2 अनुसरण करता है।

Question ID : 264330144914

Option 1 ID : 264330567913

Option 2 ID : 264330567911

Option 3 ID : 264330567912

Option 4 ID : 264330567914

Status : Answered

Chosen Option : 2

Q.19 निम्नलिखित समीकरण को सही करने के लिए किन दो चिह्नों को परस्पर बदला जाना चाहिए?

$$[[(82 + 22) - (6 \times 2)] \div (2 - 4)] \times 2 = 24$$

Ans 1. - और +

2. + और ×

3. + और ×

4. + और +

Question ID : 264330131559

Option 1 ID : 264330515341

Option 2 ID : 264330515342

Option 3 ID : 264330515339

Option 4 ID : 264330515340

Status : Answered

Chosen Option : 3

Q.20 उस विकल्प का चयन करें जिसमें दी गई आकृति अंतर्निहित है (घुमाने की अनुमति नहीं है)।



Ans

✗ 1.

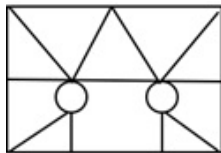

✓ 2.

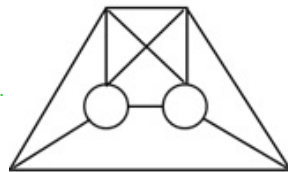

✗ 3.

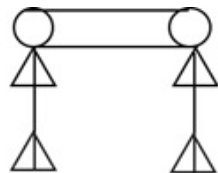

✗ 4.

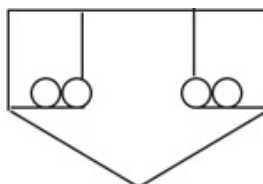

Question ID : 264330111657

Option 1 ID : 264330438713

Option 2 ID : 264330438714

Option 3 ID : 264330438716

Option 4 ID : 264330438715

Status : Answered

Chosen Option : 2

Q.21 निम्नलिखित में से उस समुच्चय का चयन कीजिए, जिसमें संख्याएँ उसी प्रकार से संबंधित हैं, जिस प्रकार दिए गए समुच्चय की संख्याएँ संबंधित हैं।

(नोट: संख्याओं को उसके घटक अंकों में विभाजित किए बिना, पूर्ण संख्याओं पर ही गणितीय संक्रियाएँ की जानी चाहिए। जैसे 13 - मान लीजिए 13 पर गणितीय संक्रियाएँ जैसे कि 13 में जोड़ना/घटाना/गुणा करना आदि किया जा सकता है। 13 को 1 और 3 में तोड़कर और फिर 1 और 3 पर गणितीय संक्रियाएँ करने की अनुमति नहीं है।)

(30, 625, 5)

(20, 225, 5)

Ans ✓ 1. (24, 256, 8)

✗ 2. (19, 122, 7)

✗ 3. (21, 297, 6)

✗ 4. (32, 280, 5)

Question ID : 26433083123

Option 1 ID : 264330326328

Option 2 ID : 264330326325

Option 3 ID : 264330326326

Option 4 ID : 264330326327

Status : Answered

Chosen Option : 1

Q.22 सात व्यक्ति तनु, रानो, बीना, शिरीन, कनक, आदित्य और अंशुल एक सीधी पंक्ति में उत्तर की ओर मुख करके बैठे हैं। तनु के बाईं ओर केवल दो व्यक्ति बैठे हैं। तनु और रानो के बीच केवल तीन व्यक्ति बैठे हैं। बीना, शिरीन के दाईं ओर दूसरे स्थान पर बैठी है। बीना, रानो की निकटतम पड़ोसी है। कनक, आदित्य के दाईं ओर ठीक बगल में बैठी है।
पंक्ति के दाएं छोर पर कौन बैठा/बैठी है?

- Ans
- 1. अंशुल
 - 2. कनक
 - 3. आदित्य
 - 4. रानो

Question ID : 26433082295
Option 1 ID : 264330323016
Option 2 ID : 264330323015
Option 3 ID : 264330323013
Option 4 ID : 264330323014
Status : Answered
Chosen Option : 4

ixamBee

Prepare 50% Faster

Q.23 उस विकल्प का चयन करें जिसमें दी गई आकृति अंतर्निहित है (घुमाने की अनुमति नहीं है)।



Ans

✗ 1.

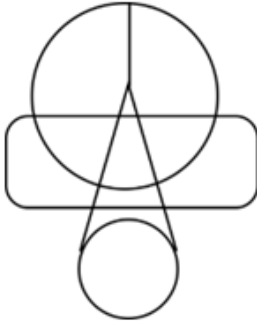

✗ 2.

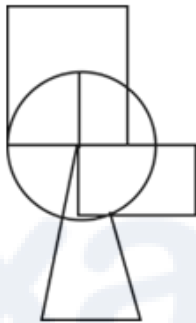

✗ 3.

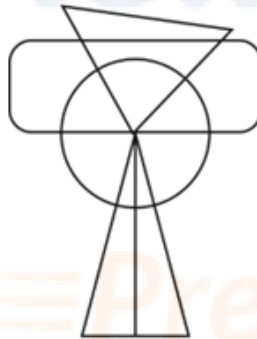

✓ 4.

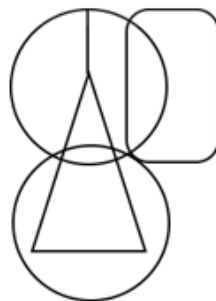

Question ID : 264330132511

Option 1 ID : 264330519139

Option 2 ID : 264330519140

Option 3 ID : 264330519141

Option 4 ID : 264330519142

Status : Answered

Chosen Option : 4

Q.24 एक निश्चित कूट भाषा में 'EXIST' को 'FYHTU' लिखा जाता है और 'ABOVE' को 'BCNWF' लिखा जाता है। उसी भाषा में 'WORLD' को कैसे लिखा जाएगा?

- Ans
- 1. YPQNE
 - 2. XPRNF
 - 3. YQQME
 - 4. XPQME

Question ID : 26433080703
Option 1 ID : 264330316747
Option 2 ID : 264330316745
Option 3 ID : 264330316748
Option 4 ID : 264330316746
Status : Answered
Chosen Option : 4

Q.25 'F + R' का अर्थ है 'F, R की माँ है'
'F - R' का अर्थ है 'F, R का पिता है'
'F ÷ R' का अर्थ है 'F, R का पति है'
'F × R' का अर्थ है 'F, R की पुत्री है'
यदि 'A ÷ C × B + Q - Z' है, तो Q, A से किस प्रकार संबंधित है?

- Ans
- 1. साला
 - 2. बहन
 - 3. दादा
 - 4. पिता

Question ID : 264330102468
Option 1 ID : 264330402303
Option 2 ID : 264330402301
Option 3 ID : 264330402302
Option 4 ID : 264330402304
Status : Answered
Chosen Option : 1

Q.26 सात लोग A, B, C, D, E, F और G उत्तर की ओर मुंह करके एक सीधी पंक्ति में बैठे हुए हैं। E के बाएं केवल 2 लोग बैठे हैं। G, E के ठीक बगल में बैठा है। B, F के दाएं ठीक बगल में बैठा है। G और F के बीच में केवल 3 लोग बैठे हैं। A, D के बाएं ठीक बगल में बैठा है।

पंक्ति के बाएं छोर पर कौन बैठा है?

- Ans
- 1. G
 - 2. C
 - 3. F
 - 4. A

Question ID : 264330144961
Option 1 ID : 264330568102
Option 2 ID : 264330568100
Option 3 ID : 264330568101
Option 4 ID : 264330568099
Status : Answered
Chosen Option : 4

Q.27 उस विकल्प का चयन करें जिसमें दी गई आकृति अंतर्निहित है (घुमाने की अनुमति नहीं है)।

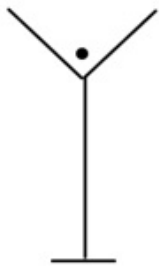

Ans

✓ 1.

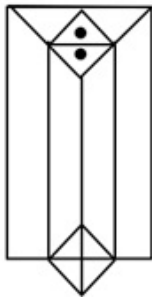

✗ 2.

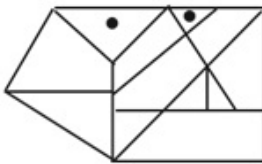

✗ 3.

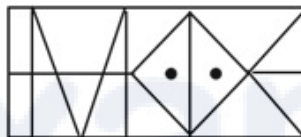

✗ 4.

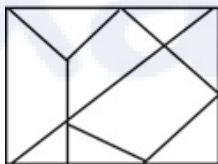

Question ID : 264330111652

Option 1 ID : 264330438695

Option 2 ID : 264330438694

Option 3 ID : 264330438696

Option 4 ID : 264330438693

Status : Answered

Chosen Option : 1

Q.28 निम्नलिखित में से कौन-सी संख्या, दी गई श्रृंखला में प्रश्नचिह्न (?) को प्रतिस्थापित करेगी?
69, 70, 74, 83, ?, 124

Ans ✓ 1. 99

✗ 2. 112

✗ 3. 120

✗ 4. 93

Question ID : 264330102161

Option 1 ID : 264330401111

Option 2 ID : 264330401110

Option 3 ID : 264330401112

Option 4 ID : 264330401109

Status : Answered

Chosen Option : 1

Q.29 गणितीय चिह्नों के उचित संयोजन को चुनिए, जो 'A' को क्रमिक रूप से प्रतिस्थापित कर सके और दिए गए समीकरण को संतुलित कर सके।
28 A 14 A 12 A 6 A 4 A 3 A 4

- Ans 1. +, -, +, x, =, +
 2. -, +, +, =, x, +
 3. -, +, +, x, =, +
 4. -, +, x, =, +, +

Question ID : 264330129586

Option 1 ID : 264330507712

Option 2 ID : 264330507713

Option 3 ID : 264330507711

Option 4 ID : 264330507710

Status : Answered

Chosen Option : 2

Q.30 यदि 'A' का अर्थ '+' है, 'B' का अर्थ 'x' है, 'C' का अर्थ '-' है और 'D' का अर्थ '-' है, तो निम्नलिखित समीकरण में प्रश्न चिह्न (?) के स्थान पर क्या आएगा?
11 B 10 D 18 A 3 C 8 = ?

- Ans 1. 112
 2. 122
 3. 132
 4. 142

Question ID : 264330141900

Option 1 ID : 264330555919

Option 2 ID : 264330555920

Option 3 ID : 264330555921

Option 4 ID : 264330555922

Status : Answered

Chosen Option : 1

Q.31 दिए गए विकल्पों में से उस संख्या का चयन कीजिए जो निम्नलिखित श्रृंखला में प्रश्न चिह्न (?) के स्थान पर आ सकती है।
63, 78, 108, 153, ?

- Ans 1. 207
 2. 213
 3. 185
 4. 193

Question ID : 264330112668

Option 1 ID : 264330442759

Option 2 ID : 264330442760

Option 3 ID : 264330442757

Option 4 ID : 264330442758

Status : Answered

Chosen Option : 2

Q.32 दिए गए कथनों और निष्कर्षों को ध्यानपूर्वक पढ़ें। यह मानते हुए कि कथनों में दी गई जानकारी सत्य है, भले ही वह सामान्य रूप से ज्ञात तथ्यों से भिन्न प्रतीत होती हो, और तय करें कि दिए गए निष्कर्षों में से कौन-सा/से निष्कर्ष कथनों का तार्किक रूप से अनुसरण करता है/करते हैं।

कथन:

- 1) सभी ब्रेड केक हैं।
- 2) कुछ केक पेस्ट्री हैं।
- 3) सभी पेस्ट्री टॉफी हैं।

निष्कर्ष:

- I. सभी केक टॉफी हैं।
- II. कोई भी ब्रेड पेस्ट्री नहीं है।

- Ans
- 1. केवल निष्कर्ष I अनुसरण करता है।
 - 2. निष्कर्ष I और II दोनों अनुसरण करते हैं।
 - 3. न तो निष्कर्ष I अनुसरण करता और न ही II अनुसरण करता है।
 - 4. केवल निष्कर्ष II अनुसरण करता है।

Question ID : 26433092433
Option 1 ID : 264330363021
Option 2 ID : 264330363024
Option 3 ID : 264330363023
Option 4 ID : 264330363022
Status : Answered
Chosen Option : 4

Q.33 यदि '+' का अर्थ '-', '-' का अर्थ 'x', '÷' का अर्थ '+', 'x' का अर्थ '÷' है, तो निम्नलिखित व्यंजक का मान ज्ञात करें।

$$7 - 12 + 72 \times 3 \div 11 = ?$$

- Ans
- 1. 66
 - 2. 71
 - 3. 82
 - 4. 76

Question ID : 264330130351
Option 1 ID : 264330510518
Option 2 ID : 264330510515
Option 3 ID : 264330510517
Option 4 ID : 264330510516
Status : Answered
Chosen Option : 2

Q.34 निम्नलिखित में से कौन-सा पद दी गई श्रृंखला में प्रश्न-चिह्न (?) को प्रतिस्थापित करेगा?
NLJ, JHF, FDB, BZX, ?

- Ans
- 1. YUX
 - 2. XUT
 - 3. YVW
 - 4. XVT

Question ID : 26433090152
Option 1 ID : 264330354086
Option 2 ID : 264330354087
Option 3 ID : 264330354088
Option 4 ID : 264330354085
Status : Answered
Chosen Option : 4

Q.35 दिए गए विकल्पों में से उस संख्या का चयन कीजिए जो निम्नलिखित श्रृंखला में प्रश्न चिह्न (?) के स्थान पर आ सकती है।
13, 39, 65, 91, 117, ?

- Ans 1. 143
 2. 145
 3. 130
 4. 127

Question ID : 264330112658
Option 1 ID : 264330442718
Option 2 ID : 264330442717
Option 3 ID : 264330442719
Option 4 ID : 264330442720
Status : Answered
Chosen Option : 1

Q.36 दी गई आकृति में कितने त्रिभुज हैं?

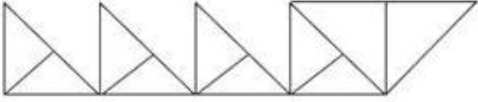

- Ans 1. 15
 2. 13
 3. 12
 4. 14

Question ID : 26433068625
Option 1 ID : 264330269013
Option 2 ID : 264330269014
Option 3 ID : 264330269015
Option 4 ID : 264330269012
Status : Answered
Chosen Option : 1

Q.37 उस विकल्प का चयन कीजिए जो चौथी संख्या से उसी प्रकार संबंधित है जिस प्रकार पहली संख्या दूसरी संख्या से संबंधित है और पांचवीं संख्या छठी संख्या से संबंधित है?

54 : 3 :: ? : 4 :: 500 : 5

- Ans 1. 100
 2. 154
 3. 192
 4. 121

Question ID : 264330144875
Option 1 ID : 264330567758
Option 2 ID : 264330567756
Option 3 ID : 264330567755
Option 4 ID : 264330567757
Status : Answered
Chosen Option : 3

Q.38 उस आकृति का चयन कीजिए जो निम्नांकित श्रृंखला में आगे आएगी।

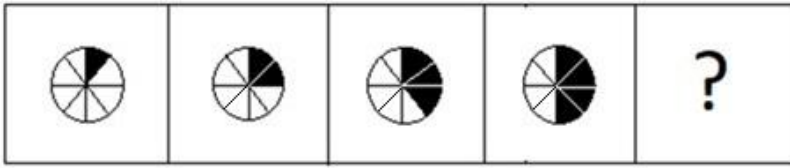

Ans

✗ 1.



✗ 2.

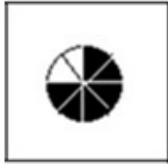

✓ 3.



✗ 4.



Question ID : 264330122476
Option 1 ID : 264330480030
Option 2 ID : 264330480027
Option 3 ID : 264330480029
Option 4 ID : 264330480028
Status : Answered
Chosen Option : 3

Q.39 यदि 1 जनवरी 2017 को रविवार था, तो 1 जनवरी 2016 को सप्ताह का कौन-सा दिन था?

Ans ✗ 1. शनिवार

✗ 2. गुरुवार

✗ 3. रविवार

✓ 4. शुक्रवार

Question ID : 264330144945
Option 1 ID : 264330568037
Option 2 ID : 264330568035
Option 3 ID : 264330568038
Option 4 ID : 264330568036
Status : Answered
Chosen Option : 4

Q.40 'A + B' का अर्थ है 'A, B का भाई है'
'A - B' का अर्थ है 'A, B की माँ है'
'A × B' का अर्थ है 'A, B का पति है'
'A ÷ B' का अर्थ है 'A, B की बहन है'
यदि 'C + M - S × K - T ÷ Q' है, तो निम्न में से कौन सा कथन सही नहीं है?

- Ans
- 1. S, Q का पिता है।
 - 2. M, Q की दादी है।
 - 3. Q, T का पति है।
 - 4. C, S का मामा है।

Question ID : 264330102483

Option 1 ID : 264330402363

Option 2 ID : 264330402362

Option 3 ID : 264330402361

Option 4 ID : 264330402364

Status : Answered

Chosen Option : 3

Q.41 तीन कथनों के बाद I, II और III से संख्यांकित तीन निष्कर्ष दिए गए हैं। कथनों को सत्य मानते हुए, भले ही वे सामान्य रूप से ज्ञात तथ्यों से भिन्न प्रतीत होते हों, तय करें कि दिए गए निष्कर्षों में से कौन सा/से निष्कर्ष कथनों का तार्किक रूप से अनुसरण करता है/करते हैं।

कथन:

सभी होल्डर, हैंगर हैं।

सभी हैंगर, हथौड़े हैं।

कुछ हथौड़े, कुल्हाड़ी हैं।

निष्कर्ष:

I. कुछ कुल्हाड़ी, हैंगर हैं।

II. कुछ हथौड़े, होल्डर हैं।

III. कुछ हैंगर, होल्डर हैं।

- Ans
- 1. केवल निष्कर्ष II और III अनुसरण करते हैं
 - 2. केवल निष्कर्ष I और II अनुसरण करते हैं
 - 3. केवल निष्कर्ष I और III अनुसरण करते हैं
 - 4. कोई भी निष्कर्ष अनुसरण नहीं करता है

Question ID : 26433097231

Option 1 ID : 264330381622

Option 2 ID : 264330381621

Option 3 ID : 264330381623

Option 4 ID : 264330381624

Status : Answered

Chosen Option : 2

Q.42 दिए गए विकल्पों में से उस संख्या का चयन कीजिए जो निम्नलिखित श्रृंखला में प्रश्न चिह्न (?) के स्थान पर आ सकती है।
363, 344, 325, 306, ?

- Ans
- 1. 287
 - 2. 291
 - 3. 285
 - 4. 293

Question ID : 264330112670

Option 1 ID : 264330442766

Option 2 ID : 264330442767

Option 3 ID : 264330442765

Option 4 ID : 264330442768

Status : Answered

Chosen Option : 1

Q.43 यदि '+' का अर्थ 'के द्वारा विभाजित' है। '-' का अर्थ 'में जोड़ा गया' है, '×' का अर्थ 'से घटाया गया' है और '÷' का अर्थ 'के द्वारा गुणा किया गया' है, तो निम्न व्यंजक का मान क्या होगा?

$$(43 \times 23 - (4 \div 3)) + (12 - 4) \div 3$$

- Ans
- 1. 2
 - 2. 4
 - 3. 6
 - 4. 5

Question ID : 264330144869

Option 1 ID : 264330567731

Option 2 ID : 264330567732

Option 3 ID : 264330567734

Option 4 ID : 264330567733

Status : Answered

Chosen Option : 3

Q.44 Select the correct option that indicates the arrangement of the following words in a logical and meaningful order.

1. Senior secondary school
2. Primary school
3. Secondary school
4. Kindergarten
5. College

- Ans
- 1. 4, 3, 2, 5, 1
 - 2. 4, 3, 2, 1, 5
 - 3. 2, 4, 3, 1, 5
 - 4. 4, 2, 3, 1, 5

Question ID : 264330132910

Option 1 ID : 264330520699

Option 2 ID : 264330520700

Option 3 ID : 264330520701

Option 4 ID : 264330520702

Status : Answered

Chosen Option : 4

Q.45 निम्नलिखित में से कौन-सी संख्याओं को (अंकों को नहीं) आपस में प्रतिस्थापित करने पर दिया गया समीकरण संतुलित हो जाएगा?

$$14 \times 4 \div 10 + 10 - 20 = 2$$

- Ans
- 1. 10, 20
 - 2. 2, 14
 - 3. 4, 20
 - 4. 2, 10

Question ID : 264330144862

Option 1 ID : 264330567706

Option 2 ID : 264330567703

Option 3 ID : 264330567704

Option 4 ID : 264330567705

Status : Answered

Chosen Option : 4

Q.46 एक निश्चित कूट भाषा में 'ACTION' को 'DFWFLK' लिखा जाता है और 'BISHOP' को 'ELVELM' लिखा जाता है। उसी भाषा में 'MATTER' को कैसे लिखा जाएगा?

- Ans 1. PDWQBO
 2. QDWQCO
 3. QEWQBO
 4. PEXQCO

Question ID : 26433080702
Option 1 ID : 264330316742
Option 2 ID : 264330316743
Option 3 ID : 264330316744
Option 4 ID : 264330316741
Status : Answered
Chosen Option : 1

Q.47 निम्नलिखित पदों में से कौन-सा पद दी गई श्रृंखला में प्रश्न चिह्न (?) को प्रतिस्थापित करेगा?
DCZ, FFY, ?, JLW, LOV

- Ans 1. HIX
 2. GJX
 3. HJX
 4. FHY

Question ID : 26433089480
Option 1 ID : 264330351421
Option 2 ID : 264330351422
Option 3 ID : 264330351424
Option 4 ID : 264330351423
Status : Answered
Chosen Option : 1

Q.48 उस समुच्चय का चयन कीजिए, जिसमें संख्याएँ उसी तरह से संबंधित हैं, जिस प्रकार दिए गए समुच्चय की संख्याएँ आपस में संबंधित हैं। (नोट: संख्याओं को उसके घटक अंकों में विभाजित किए बिना, पूर्ण संख्याओं पर ही गणितीय संक्रियाएँ की जानी चाहिए। जैसे 13 - मान लीजिए 13 पर गणितीय संक्रियाएँ जैसे कि 13 में जोड़ना/घटाना/गुणा करना आदि किया जा सकता है। 13 को 1 और 3 में तोड़कर और फिर 1 और 3 पर गणितीय संक्रियाएँ करने की अनुमति नहीं है।)
(4, 10, 23)
(8, 22, 47)

- Ans 1. (5, 13, 23)
 2. (10, 28, 53)
 3. (7, 19, 41)
 4. (6, 16, 29)

Question ID : 26433078964
Option 1 ID : 264330309871
Option 2 ID : 264330309870
Option 3 ID : 264330309869
Option 4 ID : 264330309868
Status : Answered
Chosen Option : 3

Q.49 उस विकल्प का चयन कीजिए जो पाँचवीं संख्या से उसी प्रकार संबंधित हो, जैसे दूसरी संख्या पहली संख्या से संबंधित है और चौथी संख्या तीसरी संख्या से संबंधित है।
15 : 220 :: 10 : 95 :: 12 : ?

- Ans
- 1. 180
 - 2. 144
 - 3. 152
 - 4. 139

Question ID : 26433089558
Option 1 ID : 264330351736
Option 2 ID : 264330351733
Option 3 ID : 264330351735
Option 4 ID : 264330351734
Status : Answered
Chosen Option : 4

Q.50 यदि $D = B > C = F$ और $F < B = E < A$ है, तो निम्नलिखित में से कौन-सा विकल्प सही नहीं है?

- Ans
- 1. $A < F$
 - 2. $A > C$
 - 3. $F < E$
 - 4. $E = D$

Question ID : 26433097270
Option 1 ID : 264330381780
Option 2 ID : 264330381779
Option 3 ID : 264330381777
Option 4 ID : 264330381778
Status : Answered
Chosen Option : 1

Section : General Awareness

Q.1 भारत के योजना आयोग (2011-2012) के अनुसार, राज्यों के निम्नलिखित में से किस समूह में गरीबी रेखा के नीचे की जनसंख्या का प्रतिशत सर्वाधिक है?

- Ans
- 1. बिहार और ओडिशा
 - 2. छत्तीसगढ़ और झारखंड
 - 3. केरल और पंजाब
 - 4. गुजरात और हरियाणा

Question ID : 264330119921
Option 1 ID : 264330469959
Option 2 ID : 264330469960
Option 3 ID : 264330469962
Option 4 ID : 264330469961
Status : Answered
Chosen Option : 1

Q.2 सक्रिय विलेय परिवहन द्वारा निर्मित परासरणी प्रवणता की प्रतिक्रिया में कोशिका झिल्ली में जल परिवहन किस चैनल प्रोटीन का प्राथमिक कार्य है?

- Ans
- ✓ 1. ऐक्वापोरिन (Aquaporins)
 - ✗ 2. क्यूप्रेडॉक्सिन (Cupredoxins)
 - ✗ 3. म्यूसिन (Mucins)
 - ✗ 4. ट्रांसफेरिन (Transferrin)

Question ID : 264330113466

Option 1 ID : 264330445951

Option 2 ID : 264330445950

Option 3 ID : 264330445952

Option 4 ID : 264330445949

Status : Answered

Chosen Option : 1

Q.3 पश्चिम बंगाल के मैग्रोव वनों को _____ भी कहा जाता है।

- Ans
- ✗ 1. साल
 - ✗ 2. शोला
 - ✓ 3. सुंदरबन
 - ✗ 4. शीशम

Question ID : 264330170000

Option 1 ID : 264330666675

Option 2 ID : 264330666677

Option 3 ID : 264330666676

Option 4 ID : 264330666678

Status : Answered

Chosen Option : 3

Q.4 DFC का पूर्ण रूप क्या है?

- Ans
- ✗ 1. Dangerous Food Chain (डेंजरस फूड चेन)
 - ✗ 2. Dead Food Chain (डेड फूड चेन)
 - ✗ 3. Dark Food Chain (डार्क फूड चेन)
 - ✓ 4. Detritus Food Chain (डेट्रिटस फूड चेन)

Question ID : 264330111559

Option 1 ID : 264330438324

Option 2 ID : 264330438321

Option 3 ID : 264330438322

Option 4 ID : 264330438323

Status : Answered

Chosen Option : 4

Q.5 हड़प्पा सभ्यता की जलनिकासी व्यवस्था के संबंध में दिए गए कथनों के आधार पर सही विकल्प का चयन कीजिए।

कथन I: हड़प्पा के अधिकांश शहरों में घरों के बाहर खुली जलनिकासी व्यवस्था थी।

कथन II: हड़प्पा सभ्यता में, जल और अपशिष्ट घरों के बाहर स्थित नालियों से निकलकर मुख्य भूमिगत नाली में चला जाता था।

- Ans
- 1. केवल कथन I सत्य है।
 - 2. न तो कथन I सत्य है और न ही कथन II सत्य है।
 - 3. केवल कथन II सत्य है।
 - 4. कथन I और कथन II दोनों सत्य हैं।

Question ID : 264330141807

Option 1 ID : 264330555547

Option 2 ID : 264330555550

Option 3 ID : 264330555548

Option 4 ID : 264330555549

Status : Answered

Chosen Option : 3

Q.6 भारतीय ओलंपिक संघ किससे संबद्ध है?

- Ans
- 1. अंतरराष्ट्रीय ओलंपिक समिति
 - 2. अंतर्राष्ट्रीय ओलंपिक संघ
 - 3. अंतर्राष्ट्रीय ओलंपिक परिषद
 - 4. अंतर्राष्ट्रीय ओलंपिक महासंघ

Question ID : 264330110383

Option 1 ID : 264330433811

Option 2 ID : 264330433810

Option 3 ID : 264330433809

Option 4 ID : 264330433812

Status : Answered

Chosen Option : 2

Q.7 "महाभाष्य" के लेखक कौन थे?

- Ans
- 1. पतंजलि
 - 2. कौटिल्य
 - 3. पाणिनी
 - 4. बाण

Question ID : 264330112145

Option 1 ID : 264330440667

Option 2 ID : 264330440666

Option 3 ID : 264330440665

Option 4 ID : 264330440668

Status : Answered

Chosen Option : 3

Q.8 मानक तीरंदाजी स्पर्धा में प्रयुक्त होने वाले लक्ष्य में कितने वृत्त क्षेत्र होते हैं?

- Ans 1. 8
 2. 12
 3. 10
 4. 15

Question ID : 264330119291
Option 1 ID : 264330467451
Option 2 ID : 264330467452
Option 3 ID : 264330467454
Option 4 ID : 264330467453
Status : Answered
Chosen Option : 3

Q.9 निम्नलिखित में से किस परत में ओजोन होती है?

- Ans 1. क्षीमंडल
 2. तापमंडल
 3. समतापमंडल
 4. मध्यमंडल

Question ID : 264330117621
Option 1 ID : 264330462511
Option 2 ID : 264330462512
Option 3 ID : 264330462509
Option 4 ID : 264330462510
Status : Answered
Chosen Option : 1

Q.10 73वें संविधान संशोधन अधिनियम, 1992 के माध्यम से सरकार ने अनुच्छेद _____ में वर्णित संवैधानिक दायित्व को पूरा किया।

- Ans 1. 41
 2. 43
 3. 40
 4. 42

Question ID : 264330112782
Option 1 ID : 264330443214
Option 2 ID : 264330443216
Option 3 ID : 264330443213
Option 4 ID : 264330443215
Status : Answered
Chosen Option : 4

Q.11 'गोल' (Goal) _____ की आत्मकथा है।

- Ans 1. माइक टॉयसन
 2. मेजर ध्यानचंद
 3. मैरी कॉम
 4. क्रिस्टियानो रोनाल्डो

Question ID : 264330110327
Option 1 ID : 264330433585
Option 2 ID : 264330433586
Option 3 ID : 264330433587
Option 4 ID : 264330433588
Status : Answered
Chosen Option : 2

Q.12 केंद्रशासित प्रदेश लद्दाख की झांकी नई दिल्ली में राजपथ पर पहली बार किस वर्ष प्रदर्शित की गई थी?

- Ans 1. 2020
 2. 2021
 3. 2019
 4. 2022

Question ID : 26433074084
Option 1 ID : 264330290458
Option 2 ID : 264330290459
Option 3 ID : 264330290456
Option 4 ID : 264330290457
Status : Answered
Chosen Option : 2

Q.13 सौर ऊर्जा भंडारण क्षमता वाली मोमबत्तियाँ और पैराफिन मोम बनाने के लिए 20 कार्बन परमाणुओं से बना कौन-सा असंतृप्त ऐलिफैटिक हाइड्रो कार्बन उपयोग किया जाता है ?

- Ans 1. ट्रा क्वाइन्टेन (Triacontane)
 2. आइकोसेन (Eicosane)
 3. ऑक्टेन (Octane)
 4. नोनेन (Nonane)

Question ID : 264330165459
Option 1 ID : 264330648918
Option 2 ID : 264330648916
Option 3 ID : 264330648917
Option 4 ID : 264330648915
Status : Not Answered
Chosen Option : --

Q.14 भारत ने दूसरी बार एशियाई खेलों का आयोजन किस वर्ष में किया था?

- Ans 1. 1984 में
 2. 1982 में
 3. 1951 में
 4. 1976 में

Question ID : 264330110367
Option 1 ID : 264330433748
Option 2 ID : 264330433747
Option 3 ID : 264330433745
Option 4 ID : 264330433746
Status : Answered
Chosen Option : 1

Q.15 द्वितीय पंचवर्षीय योजना के दौरान विदेशी सहयोग से कितने एकीकृत इस्पात संयंत्र स्थापित किए गए?

- Ans 1. 3
 2. 6
 3. 5
 4. 9

Question ID : 264330163213
Option 1 ID : 264330640165
Option 2 ID : 264330640164
Option 3 ID : 264330640166
Option 4 ID : 264330640163
Status : Not Answered
Chosen Option : --

Q.16 इंडिया गेट, जिसे अखिल भारतीय युद्ध स्मारक भी कहा जाता है, को किसने डिजाइन किया था?

- Ans
- 1. फ्रेड्रिक फ़ोर्सिथ
 - 2. जॉन टेलर
 - 3. चार्ल्स कोरी
 - 4. एडविन लुटियंस

Question ID : 26433064400
Option 1 ID : 264330252195
Option 2 ID : 264330252194
Option 3 ID : 264330252192
Option 4 ID : 264330252193
Status : Answered
Chosen Option : 4

Q.17 इनमें से कौन 'तमस' नामक उपन्यास के रचयिता हैं?

- Ans
- 1. भीष्म साहनी
 - 2. हरिशंकर परसाई
 - 3. राही मासूम रज़ा
 - 4. मोहन राकेश

Question ID : 264330144839
Option 1 ID : 264330567613
Option 2 ID : 264330567612
Option 3 ID : 264330567611
Option 4 ID : 264330567614
Status : Answered
Chosen Option : 2

Q.18 शरीर की प्रतिरक्षा प्रणाली किस स्थिति में वास्तविक आंतर फैक्टर प्रोटीन या आपके आमाशय की परत में इसे बनाने वाली कोशिकाओं पर हमला करती है?

- Ans
- 1. हार्टनप रोग (Hartnup disorder)
 - 2. प्रणाशी अरक्तता (Pernicious anaemia)
 - 3. वर्निक-कोर्साकॉफ सिंड्रोम (Wernicke-Korsakoff syndrome)
 - 4. यकृत सिरोसिस (Hepatic cirrhosis)

Question ID : 264330131720
Option 1 ID : 264330515982
Option 2 ID : 264330515980
Option 3 ID : 264330515981
Option 4 ID : 264330515979
Status : Not Answered
Chosen Option : --

Q.19 'गुग्गा (गोगा) नवमी' - हरियाणा और पंजाब, राजस्थान, यूपी एवं हिमाचल प्रदेश के कुछ हिस्सों में मनाया जाने वाला त्योहार है। इसे _____ के त्योहार के रूप में जाना जाता है?

- Ans
- 1. गाय पूजा
 - 2. उल्लू पूजा
 - 3. नाग पूजा
 - 4. ऊँट पूजा

Question ID : 264330111157
Option 1 ID : 264330436716
Option 2 ID : 264330436714
Option 3 ID : 264330436713
Option 4 ID : 264330436715
Status : Answered
Chosen Option : 3

Q.20 In July 1968, Indira Gandhi, the then Prime Minister of India, officially recorded impressive strides of the Green Revolution in agriculture by releasing a special stamp entitled _____.

- Ans
- 1. Fasal Kranti
 - 2. Green Revolution
 - 3. Wheat Revolution
 - 4. Harit Kranti

Question ID : 26433064537
Option 1 ID : 264330252743
Option 2 ID : 264330252740
Option 3 ID : 264330252741
Option 4 ID : 264330252742
Status : Answered
Chosen Option : 4

Q.21 निम्नलिखित में से किस गायक को भारत-रत्न से सम्मानित किया गया है?

- Ans
- 1. मोहम्मद रफ़ी
 - 2. लता मंगेशकर
 - 3. मुकेश
 - 4. आशा भोंसले

Question ID : 26433064244
Option 1 ID : 264330251570
Option 2 ID : 264330251569
Option 3 ID : 264330251571
Option 4 ID : 264330251568
Status : Answered
Chosen Option : 2

Q.22 निम्नलिखित में से किस अधिनियम को मॉर्ले-मिंटो सुधार के रूप में भी जाना जाता है?

- Ans
- 1. भारत सरकार अधिनियम, 1919
 - 2. भारत सरकार अधिनियम, 1935
 - 3. भारतीय परिषद अधिनियम, 1892
 - 4. भारतीय परिषद अधिनियम, 1909

Question ID : 264330111396
Option 1 ID : 264330437672
Option 2 ID : 264330437671
Option 3 ID : 264330437670
Option 4 ID : 264330437669
Status : Answered
Chosen Option : 1

Q.23 लिम्बा राम किस खेल से संबंधित है?

- Ans
- 1. बैडमिंटन
 - 2. तीरंदाजी
 - 3. एथलेटिक्स
 - 4. पोलो

Question ID : 264330110387
Option 1 ID : 264330433825
Option 2 ID : 264330433828
Option 3 ID : 264330433826
Option 4 ID : 264330433827
Status : Answered
Chosen Option : 2

Q.24 'इफ गॉड वाज़ ए बैंकर' पुस्तक किसने लिखी है?

- Ans
- 1. अमिताव घोष
 - 2. अश्विन सांची
 - 3. रवि सुब्रमण्यम
 - 4. झुम्पा लाहिड़ी

Question ID : 26433071713
Option 1 ID : 264330281277
Option 2 ID : 264330281276
Option 3 ID : 264330281278
Option 4 ID : 264330281279
Status : Answered
Chosen Option : 1

Q.25 निम्नलिखित में से कौन-सा आर्थोपोडा संघ का सदस्य नहीं है?

- Ans
- 1. घोंघा
 - 2. झींगा
 - 3. टिड्डी
 - 4. तितली

Question ID : 264330131701
Option 1 ID : 264330515906
Option 2 ID : 264330515905
Option 3 ID : 264330515904
Option 4 ID : 264330515903
Status : Answered
Chosen Option : 4

Q.26 मार्च 2023 तक प्राप्त जानकारी के अनुसार, केंद्रीय पर्यटन मंत्री कौन हैं?

- Ans
- 1. हरदीप पुरी
 - 2. स्मृति ईरानी
 - 3. जी. किशन रेड्डी
 - 4. गजेंद्र सिंह शेखावत

Question ID : 264330165220
Option 1 ID : 264330647982
Option 2 ID : 264330647979
Option 3 ID : 264330647980
Option 4 ID : 264330647981
Status : Answered
Chosen Option : 1

Q.27 राष्ट्रीय भारतीय शास्त्रीय नृत्य संस्थान द्वारा निम्नलिखित में से कौन-सा पुरस्कार प्रदान किया जाता है?

- Ans
- 1. टैगोर रत्न पुरस्कार
 - 2. अभिनंदन सरोजा पुरस्कार
 - 3. संगीत नाटक अकादमी पुरस्कार
 - 4. पद्म विभूषण

Question ID : 264330157012
Option 1 ID : 264330615424
Option 2 ID : 264330615425
Option 3 ID : 264330615423
Option 4 ID : 264330615426
Status : Answered
Chosen Option : 3

Q.28 भारत के योजना आयोग (2011-12) के अनुसार, चंडीगढ़ में गरीबी रेखा से नीचे की जनसंख्या का प्रतिशत कितना है?

- Ans
- 1. 9.91%
 - 2. 2.77%
 - 3. 21.81%
 - 4. 9.86%

Question ID : 264330119917

Option 1 ID : 264330469944

Option 2 ID : 264330469945

Option 3 ID : 264330469946

Option 4 ID : 264330469943

Status : Not Answered

Chosen Option : --

Q.29 दिसंबर 2022 में, किसने गुजरात के 17वें मुख्यमंत्री के रूप में शपथ ली?

- Ans
- 1. भूपेंद्र रजनीकांत पटेल
 - 2. आनंदीबेन पटेल
 - 3. विजय रुपाणी
 - 4. हार्दिक पटेल

Question ID : 264330158510

Option 1 ID : 264330621399

Option 2 ID : 264330621401

Option 3 ID : 264330621400

Option 4 ID : 264330621402

Status : Answered

Chosen Option : 1

Q.30 निम्नलिखित में से किस उद्योग में बिल्ली के उद्देश्य से पादपों और पशुओं की कुछ निश्चित प्रजातियों का प्रजनन और वर्धन किया जाता है?

- Ans
- 1. प्राथमिक
 - 2. जननिक
 - 3. निर्माण
 - 4. दोहक

Question ID : 264330163215

Option 1 ID : 264330640171

Option 2 ID : 264330640174

Option 3 ID : 264330640172

Option 4 ID : 264330640173

Status : Answered

Chosen Option : 4

Q.31 भारत में कृषि भूमि पर अत्यधिक दबाव के लिए निम्नलिखित में से कौन-से कारणों को जिम्मेदार ठहराया जा सकता है?

- a) विरासत का अधिकार
- b) अलाभकारी भूमि जोत का आकार
- c) भूमि का विभाजन
- d) बहु फसल

- Ans
- 1. a, c और d
 - 2. b, c और d
 - 3. केवल a और b
 - 4. a, b और c

Question ID : 264330166818

Option 1 ID : 264330654310

Option 2 ID : 264330654308

Option 3 ID : 264330654307

Option 4 ID : 264330654309

Status : Not Answered

Chosen Option : --

Q.32 कुछ कोशिका प्रकारों में कौन-सी संरचना परत मुख्य रूप से सेल्युलोज, हेमीसेल्युलोज और लिग्निन जैसे कार्बोहाइड्रेट के 4 : 3 : 3 के अनुपात में और मोम जैसे कुछ वसायुक्त पदार्थों से बनी होती है?

- Ans
- 1. प्लाज्मा झिल्ली
 - 2. कोशिका भित्ति
 - 3. कोशिकाविलेय
 - 4. केंद्रक आवरण

Question ID : 264330113472

Option 1 ID : 264330445974

Option 2 ID : 264330445976

Option 3 ID : 264330445973

Option 4 ID : 264330445975

Status : Not Answered

Chosen Option : --

Q.33 विजयनगर साम्राज्य में आय का प्रमुख स्रोत क्या था?

- Ans
- 1. खनन
 - 2. भू राजस्व
 - 3. औद्योगिक शुल्क
 - 4. आयात शुल्क

Question ID : 264330109018

Option 1 ID : 264330428351

Option 2 ID : 264330428352

Option 3 ID : 264330428349

Option 4 ID : 264330428350

Status : Answered

Chosen Option : 4

Q.34 कॉलम-A और कॉलम-B के बीच निम्नलिखित में से कौन सा सही मेल है?

कॉलम-A (भूपर्पटी में तत्व)	कॉलम-B (भूपर्पटी में कुल %)
i. ऑक्सीजन	a. 8%
ii. सिलिकॉन	b. 28%
iii. एल्युमिनियम	c. 47%
iv. आयरन	d. 5%

- Ans
- 1. i-b, ii-a, iii-c, iv-d
 - 2. i-a, ii-b, iii-c, iv-d
 - 3. i-c, ii-a, iii-b, iv-d
 - 4. i-c, ii-b, iii-a, iv-d

Question ID : 264330111920

Option 1 ID : 264330439766

Option 2 ID : 264330439765

Option 3 ID : 264330439767

Option 4 ID : 264330439768

Status : Answered

Chosen Option : 1

Q.35 निम्नलिखित में से किस वाद्य यंत्र की कला को उस्ताद अल्ला रक्खा कुरैशी ने लोकप्रिय बनाया है?

- Ans
- 1. बांसुरी
 - 2. शहनाई
 - 3. तबला
 - 4. संतूर

Question ID : 264330144836

Option 1 ID : 264330567601

Option 2 ID : 264330567600

Option 3 ID : 264330567599

Option 4 ID : 264330567602

Status : Answered

Chosen Option : 2

Q.36 श्री नारायण गुरु ने जाति और धर्म के आधार पर होने वाले भेदों को निरर्थक माना और सभी के लिए 'एक जाति, एक धर्म और एक भगवान' के सिद्धांत का समर्थन किया। वह निम्नलिखित में से किस संगठन से संबंधित थे?

- Ans
- 1. वेद समाज
 - 2. आर्य समाज
 - 3. ब्रह्म समाज
 - 4. श्री नारायण धर्म परिपालन योगम

Question ID : 264330165402

Option 1 ID : 264330648688

Option 2 ID : 264330648689

Option 3 ID : 264330648690

Option 4 ID : 264330648687

Status : Answered

Chosen Option : 4

Q.37 निम्नलिखित कथनों में से कौन-सा सत्य है?

कथन I: शास्त्रीय नृत्यों में रस और भाव जैसी भारतीय तकनीकों की उत्पत्ति भरतमुनि के नाट्यशास्त्र में हुई है।

कथन II: भरतनाट्यम की उत्पत्ति ओडिशा में हुई है।

- Ans
- 1. केवल कथन II सत्य है।
 - 2. केवल कथन I सत्य है।
 - 3. कथन I और कथन II दोनों सत्य हैं।
 - 4. न तो कथन I सत्य है और न ही कथन II सत्य है।

Question ID : 264330141760

Option 1 ID : 264330555360

Option 2 ID : 264330555359

Option 3 ID : 264330555361

Option 4 ID : 264330555362

Status : Answered

Chosen Option : 3

Q.38 श्री एस एल भैरप्पा ने किस क्षेत्र में उच्च कोटि की विशिष्ट सेवा के लिए वर्ष 2023 में पद्म भूषण प्राप्त किया?

- Ans
- 1. व्यापार एवं उद्योग
 - 2. सामाजिक कार्य
 - 3. साहित्य एवं शिक्षा
 - 4. विज्ञान एवं अभियांत्रिकी

Question ID : 264330137290

Option 1 ID : 264330537787

Option 2 ID : 264330537790

Option 3 ID : 264330537789

Option 4 ID : 264330537788

Status : Not Answered

Chosen Option : --

Q.39 निम्नलिखित में से किस पंचवर्षीय योजना में गरीबी उन्मूलन (गरीबी हटाओ) और आत्मनिर्भरता को प्रमुख योजना उद्देश्यों के रूप में घोषित किया गया था?

- Ans
- 1. सातवीं पंचवर्षीय योजना
 - 2. आठवीं पंचवर्षीय योजना
 - 3. पांचवीं पंचवर्षीय योजना
 - 4. छठी पंचवर्षीय योजना

Question ID : 264330111735

Option 1 ID : 264330439027

Option 2 ID : 264330439028

Option 3 ID : 264330439025

Option 4 ID : 264330439026

Status : Answered

Chosen Option : 3

Q.40 किस पेशवा ने ईस्ट इंडिया कंपनी के साथ बेसिन की संधि (वसई की संधि) पर हस्ताक्षर किए थे?

- Ans
- ✓ 1. बाजीराव द्वितीय
 - ✗ 2. रघुनाथ राव
 - ✗ 3. नारायण राव
 - ✗ 4. माधव राव

Question ID : 264330112186
Option 1 ID : 264330440830
Option 2 ID : 264330440831
Option 3 ID : 264330440832
Option 4 ID : 264330440829
Status : Not Answered
Chosen Option : --

Q.41 कौन-सा अनुच्छेद उपराष्ट्रपति के निर्वाचन से संबंधित है?

- Ans
- ✗ 1. अनुच्छेद 52
 - ✗ 2. अनुच्छेद 74
 - ✓ 3. अनुच्छेद 66
 - ✗ 4. अनुच्छेद 70

Question ID : 264330165198
Option 1 ID : 264330647894
Option 2 ID : 264330647893
Option 3 ID : 264330647892
Option 4 ID : 264330647891
Status : Answered
Chosen Option : 2

Q.42 निम्नलिखित में से किस राज्य में सत्रीया नृत्य शैली प्रसिद्ध है?

- Ans
- ✗ 1. हिमाचल प्रदेश
 - ✗ 2. तमिलनाडु
 - ✗ 3. पंजाब
 - ✓ 4. असम

Question ID : 264330109268
Option 1 ID : 264330429349
Option 2 ID : 264330429350
Option 3 ID : 264330429352
Option 4 ID : 264330429351
Status : Answered
Chosen Option : 1

Q.43 जब आरबीआई (RBI) रेपो दर को कम करने का निर्णय लेता है, तो मुद्रा आपूर्ति _____।

- Ans
- ✗ 1. में कमी होगी
 - ✗ 2. शुरू में स्थिर रहेगी और फिर कमी होगी
 - ✗ 3. अप्रभावित रहेगी
 - ✓ 4. में बढ़ोतरी होगी

Question ID : 264330109093
Option 1 ID : 264330428650
Option 2 ID : 264330428652
Option 3 ID : 264330428651
Option 4 ID : 264330428649
Status : Answered
Chosen Option : 4

Q.44 निम्नलिखित में से कौन-सा एक सिंहली (श्रीलंकाई) वृत्तान्त है, जो मौर्य साम्राज्य का एक महत्वपूर्ण साहित्यिक स्रोत है?

- Ans
- 1. मुद्राराक्षस (Mudrarakshas)
 - 2. अर्थशास्त्र (Arthashastra)
 - 3. महावंश (Mahavamsa)
 - 4. इंडिका (Indica)

Question ID : 264330165338

Option 1 ID : 264330648431

Option 2 ID : 264330648434

Option 3 ID : 264330648433

Option 4 ID : 264330648432

Status : Answered

Chosen Option : 1

Q.45 भारतीय रिजर्व बैंक का राष्ट्रीयकरण कब हुआ था?

- Ans
- 1. 1 अक्टूबर 1949 को
 - 2. 1 अप्रैल 1949 को
 - 3. 1 मार्च 1949 को
 - 4. 1 जनवरी 1949 को

Question ID : 264330109975

Option 1 ID : 264330432177

Option 2 ID : 264330432180

Option 3 ID : 264330432178

Option 4 ID : 264330432179

Status : Answered

Chosen Option : 3

Q.46 Dispute between two or more states is subject to _____ jurisdiction of the Supreme Court.

- Ans
- 1. Writ Jurisdiction
 - 2. Advisory Jurisdiction
 - 3. Original Jurisdiction
 - 4. Appellate Jurisdiction

Question ID : 264330130786

Option 1 ID : 264330512255

Option 2 ID : 264330512256

Option 3 ID : 264330512258

Option 4 ID : 264330512257

Status : Answered

Chosen Option : 2

Q.47 निम्नलिखित में से कौन-सी एक क्षारीय मृदा धातु नहीं है?

- Ans
- 1. Ca
 - 2. Be
 - 3. Mg
 - 4. Na

Question ID : 264330131781

Option 1 ID : 264330516225

Option 2 ID : 264330516223

Option 3 ID : 264330516224

Option 4 ID : 264330516226

Status : Not Answered

Chosen Option : --

Q.48 पद्म भूषण, गुरु वेम्पति चित्रा सत्यम निम्नलिखित में से किस नृत्य शैली में सैकड़ों छात्रों को प्रशिक्षित करने के लिए प्रसिद्ध हैं?

- Ans
- ✓ 1. कुचिपुड़ी
 - ✗ 2. ओडिसी
 - ✗ 3. कथक
 - ✗ 4. भरतनाट्यम

Question ID : 26433099202
Option 1 ID : 264330389422
Option 2 ID : 264330389424
Option 3 ID : 264330389421
Option 4 ID : 264330389423
Status : Not Answered
Chosen Option : --

Q.49 निम्नलिखित का मिलान कीजिए।

- | | |
|--------------------------------|--------------------|
| i) गिर राष्ट्रीय उद्यान | a) गैंडे |
| ii) राजाजी राष्ट्रीय उद्यान | b) साइबेरियन क्रेन |
| iii) केवलादेव राष्ट्रीय उद्यान | c) शेर |
| iv) काजीरंगा राष्ट्रीय उद्यान | d) हाथी |

- Ans
- ✗ 1. i-a, ii-b, iii-c, iv-d
 - ✗ 2. i-d, ii-c, iii-a, iv-b
 - ✗ 3. i-d, ii-b, iii-c, iv-a
 - ✓ 4. i-c, ii-d, iii-b, iv-a

Question ID : 264330166803
Option 1 ID : 264330654249
Option 2 ID : 264330654250
Option 3 ID : 264330654247
Option 4 ID : 264330654248
Status : Answered
Chosen Option : 3

Q.50 1833 में, कार्ल फ्रेडरिक गॉस और विल्हेम एडवर्ड वेबर ने किस उपकरण का आविष्कार किया था?

- Ans
- ✓ 1. विद्युत चुंबकीय टेलीग्राफ
 - ✗ 2. ट्रांजिस्टर
 - ✗ 3. कण त्वरक
 - ✗ 4. प्रकाशीय मेसर

Question ID : 264330141664
Option 1 ID : 264330554977
Option 2 ID : 264330554976
Option 3 ID : 264330554975
Option 4 ID : 264330554978
Status : Not Answered
Chosen Option : --

Q.1 Select the most appropriate meaning of the given idiom.
Spill the beans

- Ans**
- 1. Not that difficult to comprehend
 - 2. To make fun of someone
 - 3. Reveal a secret
 - 4. Act rudely to someone

Question ID : 264330164174
Option 1 ID : 264330643947
Option 2 ID : 264330643949
Option 3 ID : 264330643950
Option 4 ID : 264330643948
Status : Answered
Chosen Option : 3

Q.2 The following sentence has been divided into parts. One of them may contain an error.
Select the part that contains the error from the given options. If you don't find any error, mark 'No error' as your answer.
The Arabian Nights / have / many interesting stories for readers.

- Ans**
- 1. The Arabian Nights
 - 2. No error
 - 3. have
 - 4. many interesting stories for readers

Question ID : 264330123029
Option 1 ID : 264330482179
Option 2 ID : 264330482182
Option 3 ID : 264330482180
Option 4 ID : 264330482181
Status : Answered
Chosen Option : 3

Q.3 The following sentence has been divided into parts. One of them may contain an error.
Select the part that contains the error from the given options.
She has been speaking / four languages / very fluent / since childhood.

- Ans**
- 1. very fluent
 - 2. She has been speaking
 - 3. since childhood.
 - 4. four languages

Question ID : 264330164237
Option 1 ID : 264330644181
Option 2 ID : 264330644179
Option 3 ID : 264330644182
Option 4 ID : 264330644180
Status : Answered
Chosen Option : 1

Q.4 Select the correct option to substitute the underlined segment in the given sentence. If no substitution is required, select 'No substitution'.

"Speak slow lest you will wake up mommy", said Emily to Tess.

- Ans
- 1. could
 - 2. would
 - 3. should
 - 4. No substitution

Question ID : 26433090826
Option 1 ID : 264330356725
Option 2 ID : 264330356727
Option 3 ID : 264330356726
Option 4 ID : 264330356728
Status : Answered
Chosen Option : 2

Q.5 Select the option that expresses the following sentence in passive voice.
The students have presented national level projects to the jury successfully.

- Ans
- 1. National level projects were presented by the students to the jury successfully.
 - 2. National level projects had been presented by the students to the jury successfully.
 - 3. National level projects have presented by the students to the jury successfully.
 - 4. National level projects have been presented by the students to the jury successfully.

Question ID : 264330164387
Option 1 ID : 264330644760
Option 2 ID : 264330644762
Option 3 ID : 264330644759
Option 4 ID : 264330644761
Status : Answered
Chosen Option : 4

Q.6 Select the most appropriate option that can substitute the underlined segment in the given sentence. If there is no need to substitute it, select 'No substitution'.
Suitable to the instructions from the higher officials, the government land was allotted to the poor.

- Ans
- 1. Despite of
 - 2. As of
 - 3. No substitution
 - 4. In accordance with

Question ID : 264330132829
Option 1 ID : 264330520403
Option 2 ID : 264330520404
Option 3 ID : 264330520406
Option 4 ID : 264330520405
Status : Answered
Chosen Option : 4

Q.7 The following sentence has been divided into parts. One of them may contain an error.
Select the part that contains the error from the given options.
The team played / extremely / good / during the match.

- Ans
- 1. extremely
 - 2. The team played
 - 3. during the match.
 - 4. good

Question ID : 264330164236
Option 1 ID : 264330644176
Option 2 ID : 264330644175
Option 3 ID : 264330644178
Option 4 ID : 264330644177
Status : Answered
Chosen Option : 2

Q.8 Select the option that expresses the given sentence in passive voice.

The stranger had intended the execution of the plot but the boys thwarted it with their subtlety.

- Ans
- 1. The execution of the plot was intended by the stranger but it had been thwarted by the boys with their subtlety.
 - 2. The execution of the plot had been intended by the stranger but it was thwarted by the boys with their subtlety.
 - 3. The execution of the plot could have been intended by the stranger but it was being thwarted by the boys with their subtlety.
 - 4. The execution of the plot was being intended by the stranger but it has been thwarted by the boys with their subtlety.

Question ID : 264330136446
Option 1 ID : 264330534544
Option 2 ID : 264330534543
Option 3 ID : 264330534545
Option 4 ID : 264330534546
Status : Answered
Chosen Option : 2

Q.9 Select the most appropriate ANTONYM of the underlined word in the given sentence.
It is a misconception that the more you learn, the more likely you are to succeed.

- Ans
- 1. Illusion
 - 2. Hallucination
 - 3. Fallacy
 - 4. Certainty

Question ID : 264330142767
Option 1 ID : 264330559344
Option 2 ID : 264330559345
Option 3 ID : 264330559346
Option 4 ID : 264330559343
Status : Answered
Chosen Option : 4

Q.10 Select the most appropriate option that can substitute the underlined segment in the given sentence.

A few boys were kept up because of disobedience.

- Ans
- 1. kept off
 - 2. kept in
 - 3. kept back
 - 4. kept on

Question ID : 264330122676

Option 1 ID : 264330480818

Option 2 ID : 264330480817

Option 3 ID : 264330480816

Option 4 ID : 264330480815

Status : Not Answered

Chosen Option : --

Q.11 Select the most appropriate option that can substitute the underlined segment in the given sentence.

They wondered about in sheepskins and goatskins in those days.

- Ans
- 1. wandered about in
 - 2. wondered in
 - 3. wander about in
 - 4. wandered in

Question ID : 264330122675

Option 1 ID : 264330480813

Option 2 ID : 264330480811

Option 3 ID : 264330480814

Option 4 ID : 264330480812

Status : Answered

Chosen Option : 4

Q.12 Select the option that expresses the given sentence in reported (or indirect) speech.

Mohan said to Hari, "I will study for the exam."

- Ans
- 1. Mohan told Hari that he would study for the exam.
 - 2. Mahon would say to Hari that he will study for the exam.
 - 3. Mohan suggested Hari that he would study for the exam.
 - 4. Mohan said to Hari that he will study for the exam.

Question ID : 264330164248

Option 1 ID : 264330644225

Option 2 ID : 264330644224

Option 3 ID : 264330644226

Option 4 ID : 264330644223

Status : Answered

Chosen Option : 1

Q.13 Select the most appropriate meaning of the given idiom.
Under the weather

- Ans
- 1. Surrounded by serious problems of job
 - 2. Late to reach due to bad weather
 - 3. Raining heavily
 - 4. Minor sickness

Question ID : 264330135900
Option 1 ID : 264330532456
Option 2 ID : 264330532458
Option 3 ID : 264330532455
Option 4 ID : 264330532457
Status : Answered
Chosen Option : 1

Q.14 Select the most appropriate option that can substitute the underlined segment in the given sentence.

Me and Samridhi live here.

- Ans
- 1. Samridhi and me
 - 2. Samridhi and I
 - 3. Samridhi with I
 - 4. I and Samridhi

Question ID : 264330117265
Option 1 ID : 264330461118
Option 2 ID : 264330461119
Option 3 ID : 264330461120
Option 4 ID : 264330461117
Status : Answered
Chosen Option : 2

Q.15 Select the most appropriate option that can substitute the underlined segment in the given sentence.

My brother is resembling my mother.

- Ans
- 1. had resembled
 - 2. was resembling
 - 3. had been resembling
 - 4. resembles

Question ID : 264330102393
Option 1 ID : 264330402037
Option 2 ID : 264330402039
Option 3 ID : 264330402040
Option 4 ID : 264330402038
Status : Answered
Chosen Option : 2

Q.16 Select the most appropriate option that can substitute the underlined segment in the given sentence.

The scientist says that while the complete core meltdown at Chernobyl was a major disaster, it had fall far short of catastrophe many nuclear power critics had feared, the so-called 'China Syndrome'.

- Ans
- 1. it fell much short of the catastrophe
 - 2. it fell far shorter of the catastrophe
 - 3. it fell far away of the catastrophe
 - 4. it fell far short of the catastrophe

Question ID : 264330120590

Option 1 ID : 264330472605

Option 2 ID : 264330472606

Option 3 ID : 264330472604

Option 4 ID : 264330472603

Status : Answered

Chosen Option : 4

Q.17 Select the most appropriate option that can substitute the underlined segment in the given sentence.

No sooner had I reached the station when the train started moving.

- Ans
- 1. when the train start moving
 - 2. than the train started moving
 - 3. then the train had started moving
 - 4. when the train had started moving

Question ID : 264330117324

Option 1 ID : 264330461356

Option 2 ID : 264330461355

Option 3 ID : 264330461354

Option 4 ID : 264330461353

Status : Answered

Chosen Option : 3

Q.18 Select the option that can substitute the underlined word segment with the most appropriate idiom.

Denim jackets are in fashion these days.

- Ans
- 1. in a nut-shell
 - 2. in lieu of
 - 3. in hand
 - 4. in vogue

Question ID : 264330165287

Option 1 ID : 264330648235

Option 2 ID : 264330648237

Option 3 ID : 264330648236

Option 4 ID : 264330648238

Status : Answered

Chosen Option : 1

Q.19 Select the most appropriate ANTONYM of the given word.
Brave

- Ans
- 1. Moving
 - 2. Fearless
 - 3. Coward
 - 4. Adulterous

Question ID : 264330168135
Option 1 ID : 264330659418
Option 2 ID : 264330659415
Option 3 ID : 264330659416
Option 4 ID : 264330659417
Status : Answered
Chosen Option : 3

Q.20 Select the option that expresses the given sentence in passive voice.
They have built a new bridge across the river.

- Ans
- 1. They have been building a new bridge across the river.
 - 2. A new bridge has been building across the river by them.
 - 3. A new bridge will have been built across the river by them.
 - 4. A new bridge has been built across the river by them.

Question ID : 264330164244
Option 1 ID : 264330644209
Option 2 ID : 264330644210
Option 3 ID : 264330644208
Option 4 ID : 264330644207
Status : Answered
Chosen Option : 4

Q.21 Select the most appropriate option that can substitute the underlined segment in the given sentence.
Unless you don't answer my question , I will not leave.

- Ans
- 1. you don't question my answer
 - 2. I don't answer my question
 - 3. you don't answer this question
 - 4. you answer my question

Question ID : 264330117260
Option 1 ID : 264330461098
Option 2 ID : 264330461100
Option 3 ID : 264330461097
Option 4 ID : 264330461099
Status : Answered
Chosen Option : 3

Q.22 Parts of the following sentence have been given as options. Select the option that contains an error.

Yesterday, I went to the store and buy some groceries.

- Ans
- 1. to the store and
 - 2. buy some groceries
 - 3. I went
 - 4. Yesterday

Question ID : 264330164556
Option 1 ID : 264330645413
Option 2 ID : 264330645414
Option 3 ID : 264330645412
Option 4 ID : 264330645411
Status : Answered
Chosen Option : 2

Q.23 Select the most appropriate meaning of the underlined idiom in the following sentence.

After much of efforts, I could finally hit the nail on the head and succeed.

- Ans
- 1. Accidentally injure oneself
 - 2. Make an error
 - 3. Speak or act precisely
 - 4. Complete a task swiftly

Question ID : 264330168144
Option 1 ID : 264330659452
Option 2 ID : 264330659453
Option 3 ID : 264330659451
Option 4 ID : 264330659454
Status : Answered
Chosen Option : 4

Q.24 Select the most appropriate synonym of the given word.
Explicit

- Ans
- 1. Droopy
 - 2. Oppress
 - 3. Obvious
 - 4. Harness

Question ID : 264330164271
Option 1 ID : 264330644308
Option 2 ID : 264330644307
Option 3 ID : 264330644310
Option 4 ID : 264330644309
Status : Not Answered
Chosen Option : --

Q.25 Select the grammatically correct sentence.

- A. One of most serious issues with youngsters is an addiction to social media. An issue which needs attention.
B. One of the most serious issues with youngsters is addiction to social media. An issue which needs attention.
C. One of the most serious issues with youngsters is an addiction to social media. Issue which needs attention.
D. One of the most serious issues with youngsters is an addiction to social media. An issue which needs attention.

Ans ✓ 1. D

✗ 2. C

✗ 3. B

✗ 4. A

Question ID : 26433094789
Option 1 ID : 264330371980
Option 2 ID : 264330371979
Option 3 ID : 264330371978
Option 4 ID : 264330371977
Status : Answered
Chosen Option : 1

Q.26 Select the most appropriate ANTONYM of the given word.

Virtue

Ans ✓ 1. Vice

✗ 2. Stout

✗ 3. Precise

✗ 4. Acquire

Question ID : 264330141098
Option 1 ID : 26433052741
Option 2 ID : 26433052739
Option 3 ID : 26433052742
Option 4 ID : 26433052740
Status : Answered
Chosen Option : 2

Q.27 The following sentence has been split into four segments. Identify the segment that contains a grammatical error.

It takes me an hour / to get to work at the moment, / but when the new road is finished, / it be much quicker.

Ans ✗ 1. but when the new road is finished

✗ 2. it takes me an hour

✓ 3. It be much quicker

✗ 4. to get to work at the moment

Question ID : 264330120568
Option 1 ID : 264330472515
Option 2 ID : 264330472516
Option 3 ID : 264330472517
Option 4 ID : 264330472518
Status : Answered
Chosen Option : 3

Q.28 The following sentence has been split into four segments. Identify the segment that contains a grammatical error.
I'm sure that time / changes things, but it / didn't change anything / unlike my perception of you.

- Ans
- 1. changes things, but it
 - 2. unlike my perception of you
 - 3. I'm sure that time
 - 4. didn't change anything

Question ID : 264330133408
Option 1 ID : 264330522664
Option 2 ID : 264330522666
Option 3 ID : 264330522663
Option 4 ID : 264330522665
Status : Answered
Chosen Option : 2

Q.29 Sentences of a paragraph are given below in jumbled order. Arrange the sentences in the correct order to form a meaningful and coherent paragraph.

- A. Pandit Vidyadhar Bhattacharya was consulted by Sawai Jai Singh II of Jaipur when creating these enormous instruments.
- B. The word Jantar Mantar, which in Sanskrit signifies instruments and formulas, has been corrupted.
- C. His measurements of the equinoxes' precession and the ecliptic's obliquity are his two most important contributions to astronomy.
- D. Samrat Yantra, Ram Yantra, and Jai Prakash were his original creations.

- Ans
- 1. ABCD
 - 2. BADC
 - 3. CDBA
 - 4. DACB

Question ID : 26433098156
Option 1 ID : 264330385280
Option 2 ID : 264330385279
Option 3 ID : 264330385277
Option 4 ID : 264330385278
Status : Answered
Chosen Option : 2

Q.30 Sentences of a paragraph are given below in jumbled order. Arrange the sentences in the correct order to form a meaningful and coherent paragraph.

- A. Following the demise of the Indus Valley civilisation, the Aryans migrated to India.
- B. There is proof that the Aryans possessed a scientific outlook.
- C. They held that the universe was regulated by a natural law known as Panchbhutas (five components).
- D. Prithvi (heart), Ap (water), Tejas (heat), Vayu (air), and Akasa (sky) are these factors.

- Ans
- 1. ABCD
 - 2. CDAB
 - 3. BCDA
 - 4. DBCA

Question ID : 26433098150
Option 1 ID : 264330385253
Option 2 ID : 264330385256
Option 3 ID : 264330385254
Option 4 ID : 264330385255
Status : Answered
Chosen Option : 3

Q.31 Identify the ANTONYM of the following word in the given sentence.
Humility

The little girl was humble enough to negate the ideology of her classmate whose arrogance was indomitable.

- Ans
- 1. humble
 - 2. indomitable
 - 3. negate
 - 4. arrogance

Question ID : 264330167913

Option 1 ID : 264330658571

Option 2 ID : 264330658574

Option 3 ID : 264330658572

Option 4 ID : 264330658573

Status : Answered

Chosen Option : 4

Q.32 Parts of a paragraph are given below. While the first and the last sentences (S1 and S6) are in the correct order, the parts in between are jumbled up. Arrange the parts in the correct order to form a meaningful and coherent paragraph.

S1. Obesity is a condition where the body accumulates excess fat, leading to a considerable increase in the body weight.

- A. This means adverse health effects on the people of our country
 - B. Such as high blood pressure, high cholesterol, diabetes, heart diseases leading to premature death.
 - C. It is assuming alarming proportions in our country.
 - D. To avoid this, lifestyle needs to be changed.
- S6. Lack of sports and sedentary lifestyle also contribute to higher obesity level.

- Ans
- 1. ACBD
 - 2. CBAD
 - 3. CABD
 - 4. ABDC

Question ID : 264330117463

Option 1 ID : 264330461882

Option 2 ID : 264330461881

Option 3 ID : 264330461883

Option 4 ID : 264330461884

Status : Answered

Chosen Option : 2

Q.33 Select the option that expresses the given sentence in direct speech.
My mother asked me, "Who is the new Mathematics teacher?"

- Ans
- 1. My mother asked me who the new Mathematics teacher were.
 - 2. My mother asked me who the new Mathematics teacher is.
 - 3. My mother asked me who new the Mathematics teacher was.
 - 4. My mother asked me who the new Mathematics teacher was.

Question ID : 264330137239

Option 1 ID : 264330537588

Option 2 ID : 264330537587

Option 3 ID : 264330537589

Option 4 ID : 264330537590

Status : Answered

Chosen Option : 2

Q.34 Parts of the following sentence have been given as options. Select the option that contains an error.

By the way a lorry crashed into the car but the boys were lucky and escaped with only minor injuries.

- Ans
- 1. By the way a lorry
 - 2. escaped with only minor injuries
 - 3. the boys were lucky and
 - 4. crashed into the car but

Question ID : 26433099125
Option 1 ID : 264330389117
Option 2 ID : 264330389120
Option 3 ID : 264330389119
Option 4 ID : 264330389118
Status : Answered
Chosen Option : 4

Q.35 Select the option that expresses the given sentence in passive voice.
Can you give her a book?

- Ans
- 1. Can she be given a book by you?
 - 2. Can you be given a book by her?
 - 3. Can she given a book by you?
 - 4. Can she be give a book by you?

Question ID : 264330132776
Option 1 ID : 264330520200
Option 2 ID : 264330520202
Option 3 ID : 264330520201
Option 4 ID : 264330520199
Status : Answered
Chosen Option : 1

Q.36 Select the option that expresses the given sentence in direct speech.

The security asked him who he was and which flat he wished to visit.

- Ans
- 1. The security said, "Who are you? Which flat you wished to visit?"
 - 2. The security said, "Who are you? Which flat do you wish to visit?"
 - 3. The security said, "Who are you? Which flat are you wishing to visit?"
 - 4. The security said, "Who are you? Which flat you wish to be visited?"

Question ID : 26433091867
Option 1 ID : 264330360808
Option 2 ID : 264330360807
Option 3 ID : 264330360805
Option 4 ID : 264330360806
Status : Answered
Chosen Option : 1

Q.37 The following sentence has been split into four segments. Identify the segment that contains a grammatical error.

Salman finishes the work / within hours but he / delays it if not / accompanying by Rohit.

- Ans 1. within hours but he
 2. accompanying by Rohit
 3. Salman finishes the work
 4. delays it if not

Question ID : 26433091956
Option 1 ID : 264330361162
Option 2 ID : 264330361164
Option 3 ID : 264330361161
Option 4 ID : 264330361163
Status : Answered
Chosen Option : 4

Q.38 Identify the ANTONYM of the following word in the given sentence.

Divulge

The culprit surprised everyone by opting to conceal the secret execution of his plans even after getting beaten by the police.

- Ans 1. culprit
 2. conceal
 3. execution
 4. opting

Question ID : 264330135898
Option 1 ID : 264330532447
Option 2 ID : 264330532449
Option 3 ID : 264330532450
Option 4 ID : 264330532448
Status : Answered
Chosen Option : 3

Q.39 Select the most appropriate option to fill in the blank.

On 25 August 1925, the Royal Commission on Indian Currency and Finance _____ the establishment of the Central Bank of India.

- Ans 1. censored
 2. defined
 3. proposed
 4. figured

Question ID : 26433098916
Option 1 ID : 264330388317
Option 2 ID : 264330388320
Option 3 ID : 264330388319
Option 4 ID : 264330388318
Status : Answered
Chosen Option : 3

Q.40 Select the option that expresses the given sentence in passive voice.
She promised me a treat.

- Ans
- 1. Promise of a treat was given by her to myself.
 - 2. A treat was promised to me by her.
 - 3. I have been promised treats.
 - 4. Treats have been promised to me by her.

Question ID : 264330134139
Option 1 ID : 264330525582
Option 2 ID : 264330525581
Option 3 ID : 264330525579
Option 4 ID : 264330525580
Status : Answered
Chosen Option : 2

Q.41 Select the most appropriate option to substitute the underlined segment in the given sentence.
Physical activity has been projected to be helpful on avoidance of depression, by the experts.

- Ans
- 1. projected to be helpful in the avoidance
 - 2. projected to be helpful for avoidance
 - 3. projected to be helpful about avoidance
 - 4. projected to be helpful of avoidance

Question ID : 264330117040
Option 1 ID : 264330460241
Option 2 ID : 264330460243
Option 3 ID : 264330460242
Option 4 ID : 264330460244
Status : Answered
Chosen Option : 2

Q.42 Select the option that expresses the given sentence in indirect speech.
The class teacher told, "Kneel down in the corridor."

- Ans
- 1. The class teacher ordered that they should kneel down in the corridor.
 - 2. The class teacher told that they kneel down in the corridor.
 - 3. The class teacher ordered to kneel down in the corridor.
 - 4. The class teacher had ordered to kneel down in the corridor.

Question ID : 264330167971
Option 1 ID : 264330658780
Option 2 ID : 264330658779
Option 3 ID : 264330658782
Option 4 ID : 264330658781
Status : Answered
Chosen Option : 3

Q.43 Select the most appropriate ANTONYM of the given word.
Contentment

- Ans 1. Sadness
 2. Greatness
 3. Pleasure
 4. Meanness

Question ID : 264330168278
Option 1 ID : 264330659982
Option 2 ID : 264330659980
Option 3 ID : 264330659981
Option 4 ID : 264330659979
Status : Answered
Chosen Option : 1

Q.44 Select the option that expresses the given sentence in active voice.
Will the gift be delivered by her?

- Ans 1. Will she have delivered the gift?
 2. Will she have the gift delivered?
 3. Will she delivered the gift?
 4. Will she deliver the gift?

Question ID : 264330164369
Option 1 ID : 264330644688
Option 2 ID : 264330644687
Option 3 ID : 264330644689
Option 4 ID : 264330644690
Status : Answered
Chosen Option : 3

Q.45 Select the correct direct narration of the given sentence.
Neeraj said that he would go as soon as it was possible.

- Ans 1. Neeraj say, "I shall went as soon as it is possible".
 2. Neeraj said, "I shall go as soon as it is possible".
 3. Neeraj says, "I may went as soon as it was possible".
 4. Neeraj say, "I should go as soon as it is possible".

Question ID : 264330132881
Option 1 ID : 264330520593
Option 2 ID : 264330520594
Option 3 ID : 264330520592
Option 4 ID : 264330520591
Status : Answered
Chosen Option : 2

Q.46 Select the most appropriate option that can substitute the underlined segment in the given sentence.

He was fatiguing because he spent seven break-less hours on the computer.

- Ans
- 1. was fatigueless because
 - 2. was fatigueness because
 - 3. has been fatiguing because
 - 4. was fatigued because

Question ID : 264330101001
Option 1 ID : 264330396551
Option 2 ID : 264330396552
Option 3 ID : 264330396549
Option 4 ID : 264330396550
Status : Answered
Chosen Option : 4

Q.47 The following sentence has been split into four segments. Identify the segment that contains a grammatical error.

If you have / faith in God, / everything turn out / to be all right.

- Ans
- 1. everything turn out
 - 2. If you have
 - 3. to be all right
 - 4. faith in God,

Question ID : 26433094140
Option 1 ID : 264330369563
Option 2 ID : 264330369561
Option 3 ID : 264330369564
Option 4 ID : 264330369562
Status : Answered
Chosen Option : 4

Q.48 Select the most appropriate synonym of the given word.
Beneficial

- Ans
- 1. Kernel
 - 2. Winsome
 - 3. Helpful
 - 4. Strangle

Question ID : 264330164272
Option 1 ID : 264330644312
Option 2 ID : 264330644314
Option 3 ID : 264330644313
Option 4 ID : 264330644311
Status : Answered
Chosen Option : 3

Q.49 Sentences of a paragraph are given below. While the first and the last sentences (S1 and S6) are in the correct order, the sentences in between are jumbled up. Arrange the sentences in the correct order to form a meaningful and coherent paragraph.
 S1. Generation gap is actually the difference between the ebullience of youth on the one hand and the caution and prudence of old age on the other.
 A. Or, it is expression of the rivalry between the old and the young.
 B. The old declare the younger lot to be arrogant fools; the young declare the older people to be senile and insipid.
 C. The old want to prolong their hold on authority while the young are over-eager to grab it.
 D. The gulf between the two generations cannot be bridged.
 S6. However, in modern times, lifestyles are changing so fast that the gap between any two successive generations becomes easily perceptible.

- Ans 1. CBAD
 2. CDBA
 3. ACBD
 4. CABD

Question ID : 264330117464
 Option 1 ID : 264330461888
 Option 2 ID : 264330461885
 Option 3 ID : 264330461887
 Option 4 ID : 264330461886
 Status : Answered
 Chosen Option : 1

Q.50 Select the most appropriate idiom that can substitute the underlined segment in the given sentence.

The constant noise from the construction site next door is starting to make me extremely angry.

- Ans 1. bringing me round
 2. drive me up the wall
 3. driving me blind
 4. shove me under the table

Question ID : 264330164571
 Option 1 ID : 264330645472
 Option 2 ID : 264330645471
 Option 3 ID : 264330645474
 Option 4 ID : 264330645473
 Status : Answered
 Chosen Option : 3

Q.51 Select the option that expresses the given sentence in indirect speech.
 Riya asked, "Are you feeling fine?"

- Ans 1. Riya asked me if I was feeling fine?
 2. Riya told me if I was feeling fine.
 3. Riya asked her if she was feeling fine.
 4. Riya asked me if I was feeling fine.

Question ID : 264330168335
 Option 1 ID : 264330660204
 Option 2 ID : 264330660205
 Option 3 ID : 264330660203
 Option 4 ID : 264330660206
 Status : Answered
 Chosen Option : 1

Q.52 Sentences of a paragraph are given below. While the first and the last sentences (S1 and S6) are in the correct order, the sentences in between are jumbled up. Arrange the sentences in the correct order to form a meaningful and coherent paragraph.

- S1. Sania asked Piyush how he had fared in the examination the week before.
 A. Piyush then requested Sania not to talk about it.
 B. Piyush said that he had done very badly and was afraid that he would not clear the exam.
 C. Sania exclaimed that this was his foolish fear.
 D. Sania wanted to know the reason for this request.
 S6. She knew Piyush was a hard-working boy and would definitely clear the exam.

- Ans 1. ADBC
 2. DABC
 3. ABCD
 4. ACBD

Question ID : 264330117460
 Option 1 ID : 264330461872
 Option 2 ID : 264330461871
 Option 3 ID : 264330461870
 Option 4 ID : 264330461869
 Status : Answered
 Chosen Option : 1

Q.53 Select the option that expresses the following sentence in passive voice.
 I was carrying the Indian flag.

- Ans 1. The Indian flag was being carried by me.
 2. The Indian flag were being carried by me.
 3. The Indian flag is being carried by me.
 4. The Indian flag had being carried by me.

Question ID : 264330164344
 Option 1 ID : 264330644587
 Option 2 ID : 264330644590
 Option 3 ID : 264330644588
 Option 4 ID : 264330644589
 Status : Answered
 Chosen Option : 1

Q.54 In question, four alternatives are given for the idiom under in the sentence. Choose the alternative which best expresses the meaning of the underlined idiom.
 Mr. Avinash is very nice and friendly, but his brother is very toffee-nosed.

- Ans 1. A person who never trusts anyone
 2. A person who is arrogant and cruel
 3. A person who thinks he is intelligent and perfect
 4. A person who thinks he is of a high social class and looks down on people of lower class

Question ID : 264330134120
 Option 1 ID : 264330525506
 Option 2 ID : 264330525503
 Option 3 ID : 264330525505
 Option 4 ID : 264330525504
 Status : Answered
 Chosen Option : 2

Q.55 Sentences of a paragraph are given below in jumbled order. Arrange the sentences in the correct order to form a meaningful and coherent paragraph.

A. During the period, Europeans were looking for a faster method to reach India by sailing across Africa, and Da Gama succeeded.

B. At that time, gold, spices and other valuables were highly valued in Europe.

C. Vasco da Gama was a Portuguese navigator who sailed from Europe to India.

D. However, they had to travel a vast distance by sea and land to reach them in Asia.

Ans ✓ 1. CBAD

✗ 2. ABCD

✗ 3. CDAB

✗ 4. ADCB

Question ID : 26433097524

Option 1 ID : 264330382771

Option 2 ID : 264330382769

Option 3 ID : 264330382772

Option 4 ID : 264330382770

Status : Answered

Chosen Option : 1

Q.56 Select the option that expresses the given sentence in passive voice.
 I kicked the ball.

Ans ✓ 1. The ball was kicked by me.

✗ 2. The ball had been kicked by me.

✗ 3. The ball is kicked by me.

✗ 4. The ball was kicked by you.

Question ID : 264330168328

Option 1 ID : 264330660176

Option 2 ID : 264330660177

Option 3 ID : 264330660175

Option 4 ID : 264330660178

Status : Answered

Chosen Option : 1

Q.57 Select the most appropriate ANTONYM of the bracketed word in the following sentence to fill in the blank.

My favourite _____ (deface) of his home is the large, farmhouse-style kitchen.

Ans ✗ 1. dimension

✓ 2. build

✗ 3. fact

✗ 4. regard

Question ID : 264330164223

Option 1 ID : 264330644131

Option 2 ID : 264330644134

Option 3 ID : 264330644133

Option 4 ID : 264330644132

Status : Answered

Chosen Option : 1

Q.58 Sentences of a paragraph are given below. While the first and the last sentences (S1 and S6) are in the correct order, the sentences in between are jumbled up. Arrange the sentences in the correct order to form a meaningful and coherent paragraph.

- S1. One can find ants anywhere on earth.
 A. They also use chemicals called pheromones to leave scent.
 B. They can communicate effectively with each other.
 C. Thus, they are called the earth's most successful species.
 D. There are about 2,000 species of ants.
 S6. These scent trails help other ants to follow.

- Ans 1. ABCD
 2. CDBA
 3. BACD
 4. DCBA

Question ID : 264330117277
 Option 1 ID : 264330461165
 Option 2 ID : 264330461167
 Option 3 ID : 264330461168
 Option 4 ID : 264330461166
 Status : Answered
 Chosen Option : 4

Q.59 Select the option that expresses the following sentence in indirect speech.
 She said to me, "I have often told you not to play with fire."

- Ans 1. She said to me that she has often told me not to play with fire.
 2. She asked me that she had often told me not to play with fire.
 3. She told me that she had often told me not to play with fire.
 4. She told me that she has often told me not to play with fire.

Question ID : 264330157048
 Option 1 ID : 264330615569
 Option 2 ID : 264330615568
 Option 3 ID : 264330615567
 Option 4 ID : 264330615570
 Status : Answered
 Chosen Option : 3

Q.60 Select the option that expresses the given sentence in reported speech.

He said, "I am living in Ludhiana."

- Ans 1. He said that he has been living in Ludhiana.
 2. He said that he is living in Ludhiana.
 3. He asked that he is living in Ludhiana.
 4. He said that he was living in Ludhiana.

Question ID : 264330141620
 Option 1 ID : 264330554818
 Option 2 ID : 264330554815
 Option 3 ID : 264330554816
 Option 4 ID : 264330554817
 Status : Answered
 Chosen Option : 2

Q.61 Select the option that expresses the following sentence in passive voice.

The audience loudly cheered the student leader's speech.

- Ans
- 1. The student leader was loudly cheered by the audience.
 - 2. There was a loud cheer for the student.
 - 3. The student leader's speech was loudly cheered by the audience.
 - 4. They all cheered loudly the leader's speech.

Question ID : 264330164200

Option 1 ID : 264330644048

Option 2 ID : 264330644047

Option 3 ID : 264330644050

Option 4 ID : 264330644049

Status : Answered

Chosen Option : 3

Q.62 Select the most appropriate synonym of the given word.

Apprehension

- Ans
- 1. Barbarous
 - 2. Myth
 - 3. Courage
 - 4. Fear

Question ID : 264330137010

Option 1 ID : 264330536686

Option 2 ID : 264330536684

Option 3 ID : 264330536683

Option 4 ID : 264330536685

Status : Answered

Chosen Option : 3

Q.63 Select the most appropriate option that can substitute the underlined segment in the given sentence.

The excessive using of pocket calculators can stultify your capacity to do mental calculations.

- Ans
- 1. utility of pocket calculators
 - 2. aversion of pocket calculators
 - 3. used of pocket calculators
 - 4. use of pocket calculators

Question ID : 264330117248

Option 1 ID : 264330461050

Option 2 ID : 264330461052

Option 3 ID : 264330461051

Option 4 ID : 264330461049

Status : Answered

Chosen Option : 4

Q.64 Select the option that changes the form of narration in the following sentence.

My sister asked me, "When will I be allowed to go to the church?"

- Ans
- 1. My sister asked me when she will be allowed to go to the church.
 - 2. My sister asked me that when she would be allowed to go to the church.
 - 3. My sister prayed when she will be allowed to go to the church.
 - 4. My sister asked me when she would be allowed to go to the church.

Question ID : 264330163269

Option 1 ID : 264330640389

Option 2 ID : 264330640390

Option 3 ID : 264330640387

Option 4 ID : 264330640388

Status : Answered

Chosen Option : 1

Q.65 Select the most appropriate ANTONYM of the underlined word in the following sentence.

One should celebrate every triumph in life.

- Ans
- 1. Victory
 - 2. Defeat
 - 3. Milestone
 - 4. Instrument

Question ID : 264330164308

Option 1 ID : 264330644448

Option 2 ID : 264330644449

Option 3 ID : 264330644447

Option 4 ID : 264330644450

Status : Answered

Chosen Option : 2

ixamBee

Prepare 50% Faster

Comprehension:

In the following passage, some words have been deleted. Read the passage carefully and select the most appropriate option to fill in each blank.

The London Eye, formally known as Millennium Wheel, was officially called the British Airways London Eye and then the Merlin Entertainments London Eye. The London Eye, a giant Ferris Wheel, is situated (I) _____ the banks of the River Thames in London, England. Since 20 January 2011, its official name is the EDP Energy London Eye following a three-year sponsorship deal. The (II) _____ structure is 135 m tall and the wheel has a diameter of 120 m or 394 feet. This Ferris Wheel, which is the tallest in Europe, claims to be the most popular paid tourist (III) _____ in the United Kingdom. It is visited by over 3.5 million people annually making it London's most popular tourist attraction for which an admission fee is charged and is sometimes credited with sparking a worldwide revival of Ferris wheel Construction When erected in 1999 it was the tallest Ferris wheel in the world. Until (IV) _____ first by the 160 m Star of Nanchang in 2006 and then the 165 m Singapore Flyer in 2008. (V) _____ by an A-frame on the side only, the Eye is described as 'the world's tallest cantilevered observation wheel'. It provides the highest public viewing point and can be considered as the 20th tallest structure in London.

SubQuestion No : 66

Q.66 Read the given passage carefully and select the appropriate word in the context of the whole passage to fill in the blank.

The London Eye, a giant Ferris Wheel, is situated (I) _____ the banks of the River Thames in London, England.

In the given passage the suitable word for blank (I) is:

- Ans
- 1. into
 - 2. with
 - 3. for
 - 4. on

Question ID : 264330164656

Option 1 ID : 264330645798

Option 2 ID : 264330645795

Option 3 ID : 264330645797

Option 4 ID : 264330645796

Status : Answered

Chosen Option : 4

Comprehension:

In the following passage, some words have been deleted. Read the passage carefully and select the most appropriate option to fill in each blank.

The London Eye, formally known as Millennium Wheel, was officially called the British Airways London Eye and then the Merlin Entertainments London Eye. The London Eye, a giant Ferris Wheel, is situated (I) _____ the banks of the River Thames in London, England. Since 20 January 2011, its official name is the EDP Energy London Eye following a three-year sponsorship deal. The (II) _____ structure is 135 m tall and the wheel has a diameter of 120 m or 394 feet. This Ferris Wheel, which is the tallest in Europe, claims to be the most popular paid tourist (III) _____ in the United Kingdom. It is visited by over 3.5 million people annually making it London's most popular tourist attraction for which an admission fee is charged and is sometimes credited with sparking a worldwide revival of Ferris wheel Construction When erected in 1999 it was the tallest Ferris wheel in the world. Until (IV) _____ first by the 160 m Star of Nanchang in 2006 and then the 165 m Singapore Flyer in 2008. (V) _____ by an A-frame on the side only, the Eye is described as 'the world's tallest cantilevered observation wheel'. It provides the highest public viewing point and can be considered as the 20th tallest structure in London.

SubQuestion No : 67

Q.67 Read the given passage carefully and select the appropriate word in the context of the whole passage to fill in the blank.

The (II) _____ structure is 135 m tall and the wheel has a diameter of 120 m.

In the given passage the suitable word for blank (II) is:

- Ans
- 1. remedial
 - 2. entire
 - 3. generous
 - 4. deceptive

Question ID : 264330164657

Option 1 ID : 264330645800

Option 2 ID : 264330645802

Option 3 ID : 264330645799

Option 4 ID : 264330645801

Status : Answered

Chosen Option : 2

Comprehension:

In the following passage, some words have been deleted. Read the passage carefully and select the most appropriate option to fill in each blank.

The London Eye, formally known as Millennium Wheel, was officially called the British Airways London Eye and then the Merlin Entertainments London Eye. The London Eye, a giant Ferris Wheel, is situated (I) _____ the banks of the River Thames in London, England. Since 20 January 2011, its official name is the EDP Energy London Eye following a three-year sponsorship deal. The (II) _____ structure is 135 m tall and the wheel has a diameter of 120 m or 394 feet. This Ferris Wheel, which is the tallest in Europe, claims to be the most popular paid tourist (III) _____ in the United Kingdom. It is visited by over 3.5 million people annually making it London's most popular tourist attraction for which an admission fee is charged and is sometimes credited with sparking a worldwide revival of Ferris wheel Construction When erected in 1999 it was the tallest Ferris wheel in the world. Until (IV) _____ first by the 160 m Star of Nanchang in 2006 and then the 165 m Singapore Flyer in 2008. (V) _____ by an A-frame on the side only, the Eye is described as 'the world's tallest cantilevered observation wheel'. It provides the highest public viewing point and can be considered as the 20th tallest structure in London.

SubQuestion No : 68

Q.68 Read the given passage carefully and select the appropriate word in the context of the whole passage to fill in the blank.

This Ferris Wheel, which is the tallest in Europe, claims to be the most popular paid tourist (III) _____ in the United Kingdom.

In the given passage the suitable word for blank (III) is:

- Ans 1. attraction
 2. agreement
 3. emergency
 4. juncture

Question ID : 264330164658

Option 1 ID : 264330645803

Option 2 ID : 264330645804

Option 3 ID : 264330645805

Option 4 ID : 264330645806

Status : Answered

Chosen Option : 1

Comprehension:

In the following passage, some words have been deleted. Read the passage carefully and select the most appropriate option to fill in each blank.

The London Eye, formally known as Millennium Wheel, was officially called the British Airways London Eye and then the Merlin Entertainments London Eye. The London Eye, a giant Ferris Wheel, is situated (I) _____ the banks of the River Thames in London, England. Since 20 January 2011, its official name is the EDP Energy London Eye following a three-year sponsorship deal. The (II) _____ structure is 135 m tall and the wheel has a diameter of 120 m or 394 feet. This Ferris Wheel, which is the tallest in Europe, claims to be the most popular paid tourist (III) _____ in the United Kingdom. It is visited by over 3.5 million people annually making it London's most popular tourist attraction for which an admission fee is charged and is sometimes credited with sparking a worldwide revival of Ferris wheel Construction When erected in 1999 it was the tallest Ferris wheel in the world. Until (IV) _____ first by the 160 m Star of Nanchang in 2006 and then the 165 m Singapore Flyer in 2008. (V) _____ by an A-frame on the side only, the Eye is described as 'the world's tallest cantilevered observation wheel'. It provides the highest public viewing point and can be considered as the 20th tallest structure in London.

SubQuestion No : 69

Q.69 Read the given passage carefully and select the appropriate word in the context of the whole passage to fill in the blank.

It is visited by over 3.5 million people annually. When erected in 1999 it was the tallest Ferris wheel in the world. Until (IV) _____ first by the 160 m Star of Nanchang in 2006 and then the 165 m Singapore Flyer in 2008.

In the given passage the suitable word for blank (IV) is:

Ans 1. negotiated

2. surpassed

3. disbursed

4. advanced

Question ID : 264330164659

Option 1 ID : 264330645807

Option 2 ID : 264330645808

Option 3 ID : 264330645810

Option 4 ID : 264330645809

Status : Answered

Chosen Option : 1

Comprehension:

In the following passage, some words have been deleted. Read the passage carefully and select the most appropriate option to fill in each blank.

The London Eye, formally known as Millennium Wheel, was officially called the British Airways London Eye and then the Merlin Entertainments London Eye. The London Eye, a giant Ferris Wheel, is situated (I)_____ the banks of the River Thames in London, England. Since 20 January 2011, its official name is the EDP Energy London Eye following a three-year sponsorship deal. The (II)_____ structure is 135 m tall and the wheel has a diameter of 120 m or 394 feet. This Ferris Wheel, which is the tallest in Europe, claims to be the most popular paid tourist (III)_____ in the United Kingdom. It is visited by over 3.5 million people annually making it London's most popular tourist attraction for which an admission fee is charged and is sometimes credited with sparking a worldwide revival of Ferris wheel Construction When erected in 1999 it was the tallest Ferris wheel in the world. Until (IV)_____ first by the 160 m Star of Nanchang in 2006 and then the 165 m Singapore Flyer in 2008. (V)_____ by an A-frame on the side only, the Eye is described as 'the world's tallest cantilevered observation wheel'. It provides the highest public viewing point and can be considered as the 20th tallest structure in London.

SubQuestion No : 70

Q.70 Read the given passage carefully and select the appropriate word in the context of the whole passage to fill in the blank.

(V)_____ by an A-frame on the side only, the Eye is described as 'the world's tallest cantilevered observation wheel'.

In the given passage the suitable word for blank (V) is:

- Ans
- 1. Required
 - 2. Credited
 - 3. Consumed
 - 4. Supported

Question ID : 264330164660

Option 1 ID : 264330645814

Option 2 ID : 264330645812

Option 3 ID : 264330645813

Option 4 ID : 264330645811

Status : Answered

Chosen Option : 2

Comprehension:

In the following passage, some words have been deleted. Read the passage carefully and select the most appropriate option to fill in each blank.

Global warming is a significant (1)_____ issue that requires immediate attention. The (2)_____ of greenhouse gases in the atmosphere has led to a (3)_____ increase in average temperatures worldwide. This phenomenon (4)_____ various adverse effects on the environment, including (5)_____ weather patterns and rising sea levels.

SubQuestion No : 71

Q.71 Select the most appropriate option to fill in blank number 1.

- Ans
- 1. detrimental
 - 2. environmental
 - 3. beneficial
 - 4. controversial

Question ID : 264330164678

Option 1 ID : 264330645880

Option 2 ID : 264330645879

Option 3 ID : 264330645882

Option 4 ID : 264330645881

Status : Answered

Chosen Option : 2

Comprehension:

In the following passage, some words have been deleted. Read the passage carefully and select the most appropriate option to fill in each blank.

Global warming is a significant (1)_____ issue that requires immediate attention. The (2)_____ of greenhouse gases in the atmosphere has led to a (3)_____ increase in average temperatures worldwide. This phenomenon (4)_____ various adverse effects on the environment, including (5)_____ weather patterns and rising sea levels.

SubQuestion No : 72**Q.72 Select the most appropriate option to fill in blank number 2.**

- Ans 1. emission
 2. reduction
 3. extraction
 4. production

Question ID : 264330164679

Option 1 ID : 264330645883

Option 2 ID : 264330645884

Option 3 ID : 264330645885

Option 4 ID : 264330645886

Status : Answered

Chosen Option : 1

Comprehension:

In the following passage, some words have been deleted. Read the passage carefully and select the most appropriate option to fill in each blank.

Global warming is a significant (1)_____ issue that requires immediate attention. The (2)_____ of greenhouse gases in the atmosphere has led to a (3)_____ increase in average temperatures worldwide. This phenomenon (4)_____ various adverse effects on the environment, including (5)_____ weather patterns and rising sea levels.

SubQuestion No : 73**Q.73 Select the most appropriate option to fill in blank number 3.**

- Ans 1. ineffective
 2. temporary
 3. large
 4. gradual

Question ID : 264330164680

Option 1 ID : 264330645889

Option 2 ID : 264330645888

Option 3 ID : 264330645890

Option 4 ID : 264330645887

Status : Answered

Chosen Option : 3

Comprehension:

In the following passage, some words have been deleted. Read the passage carefully and select the most appropriate option to fill in each blank.

Global warming is a significant (1)_____ issue that requires immediate attention. The (2)_____ of greenhouse gases in the atmosphere has led to a (3)_____ increase in average temperatures worldwide. This phenomenon (4)_____ various adverse effects on the environment, including (5)_____ weather patterns and rising sea levels.

SubQuestion No : 74

Q.74 Select the most appropriate option to fill in blank number 4.

- Ans 1. causes
 2. results
 3. prevents
 4. contributes

Question ID : 264330164681

Option 1 ID : 264330645892

Option 2 ID : 264330645891

Option 3 ID : 264330645894

Option 4 ID : 264330645893

Status : Answered

Chosen Option : 1

Comprehension:

In the following passage, some words have been deleted. Read the passage carefully and select the most appropriate option to fill in each blank.

Global warming is a significant (1)_____ issue that requires immediate attention. The (2)_____ of greenhouse gases in the atmosphere has led to a (3)_____ increase in average temperatures worldwide. This phenomenon (4)_____ various adverse effects on the environment, including (5)_____ weather patterns and rising sea levels.

SubQuestion No : 75

Q.75 Select the most appropriate option to fill in blank number 5.

- Ans 1. erratic
 2. stable
 3. predictable
 4. constant

Question ID : 264330164682

Option 1 ID : 264330645897

Option 2 ID : 264330645895

Option 3 ID : 264330645898

Option 4 ID : 264330645896

Status : Answered

Chosen Option : 2

Comprehension:

In the following passage, some words have been deleted. Read the passage carefully and select the most appropriate option to fill in each blank.

Necessity is an (1) _____ force that compels a man to do things. It stirs the mind so (2) _____ that it causes great unrest that continues until the necessity is (3) _____. As order comes out of (4) _____ chaos so does an invention out of some (5) _____.

SubQuestion No : 76

Q.76 Select the most appropriate option to fill in blank No. 1.

- Ans 1. inconceivable
 2. irresistible
 3. essential
 4. unpredictable

Question ID : 264330166468

Option 1 ID : 264330652915

Option 2 ID : 264330652916

Option 3 ID : 264330652918

Option 4 ID : 264330652917

Status : Answered

Chosen Option : 3

Comprehension:

In the following passage, some words have been deleted. Read the passage carefully and select the most appropriate option to fill in each blank.

Necessity is an (1) _____ force that compels a man to do things. It stirs the mind so (2) _____ that it causes great unrest that continues until the necessity is (3) _____. As order comes out of (4) _____ chaos so does an invention out of some (5) _____.

SubQuestion No : 77

Q.77 Select the most appropriate option to fill in blank No. 2.

- Ans 1. massively
 2. gracefully
 3. slowly
 4. violently

Question ID : 264330166469

Option 1 ID : 264330652922

Option 2 ID : 264330652919

Option 3 ID : 264330652921

Option 4 ID : 264330652920

Status : Answered

Chosen Option : 4

Comprehension:

In the following passage, some words have been deleted. Read the passage carefully and select the most appropriate option to fill in each blank.

Necessity is an (1) _____ force that compels a man to do things. It stirs the mind so (2) _____ that it causes great unrest that continues until the necessity is (3) _____. As order comes out of (4) _____ chaos so does an invention out of some (5) _____.

SubQuestion No : 78

Q.78 Select the most appropriate option to fill in blank No. 3.

- Ans 1. concerned
 2. committed
 3. fulfilled
 4. perturbed

Question ID : 264330166470

Option 1 ID : 264330652926

Option 2 ID : 264330652925

Option 3 ID : 264330652923

Option 4 ID : 264330652924

Status : Answered

Chosen Option : 3

Comprehension:

In the following passage, some words have been deleted. Read the passage carefully and select the most appropriate option to fill in each blank.

Necessity is an (1) _____ force that compels a man to do things. It stirs the mind so (2) _____ that it causes great unrest that continues until the necessity is (3) _____. As order comes out of (4) _____ chaos so does an invention out of some (5) _____.

SubQuestion No : 79

Q.79 Select the most appropriate option to fill in blank No. 4.

- Ans 1. perfect
 2. utter
 3. analytical
 4. least

Question ID : 264330166471

Option 1 ID : 264330652929

Option 2 ID : 264330652927

Option 3 ID : 264330652930

Option 4 ID : 264330652928

Status : Answered

Chosen Option : 1

Comprehension:

In the following passage, some words have been deleted. Read the passage carefully and select the most appropriate option to fill in each blank.

Necessity is an (1) _____ force that compels a man to do things. It stirs the mind so (2) _____ that it causes great unrest that continues until the necessity is (3) _____. As order comes out of (4) _____ chaos so does an invention out of some (5) _____.

SubQuestion No : 80

Q.80 Select the most appropriate option to fill in blank No. 5.

- Ans 1. amity
 2. ability
 3. abstrusity
 4. necessity

Question ID : 264330166472

Option 1 ID : 264330652934

Option 2 ID : 264330652931

Option 3 ID : 264330652932

Option 4 ID : 264330652933

Status : Answered

Chosen Option : 4

Comprehension:

In the following passage some words have been deleted. Read the passage carefully and select the most appropriate option to fill in each blank.

Fire is a significant factor in human (1) _____. The Stone Age man was the first to discover and use fire, which provided him (2) _____ and a means to cook food. Initially, he produced fire by rubbing two stones, and the (3) _____ between two stones generated fire. But this process was very (4) _____ and he wanted to discover a less laborious way of producing fire. For this he had to first preserve the fire. He discovered a fire band and carried it everywhere. This discovery led to the invention of torches and lamps that could be used for (5) _____, and preserving flame. So, we can say that fire is an accidental invention.

SubQuestion No : 81

Q.81 Select the most appropriate option to fill in blank number 1.

- Ans 1. recession
 2. regression
 3. evolution
 4. rotation

Question ID : 264330168070

Option 1 ID : 264330659161

Option 2 ID : 264330659159

Option 3 ID : 264330659160

Option 4 ID : 264330659162

Status : Answered

Chosen Option : 3

Comprehension:

In the following passage some words have been deleted. Read the passage carefully and select the most appropriate option to fill in each blank.

Fire is a significant factor in human (1)_____. The Stone Age man was the first to discover and use fire, which provided him (2)_____ and a means to cook food. Initially, he produced fire by rubbing two stones, and the (3)_____ between two stones generated fire. But this process was very (4)_____ and he wanted to discover a less laborious way of producing fire. For this he had to first preserve the fire. He discovered a fire band and carried it everywhere. This discovery led to the invention of torches and lamps that could be used for (5)_____, and preserving flame. So, we can say that fire is an accidental invention.

SubQuestion No : 82

Q.82 Select the most appropriate option to fill in blank number 2.

- Ans 1. warm
 2. coldness
 3. hot
 4. warmth

Question ID : 264330168071

Option 1 ID : 264330659164

Option 2 ID : 264330659166

Option 3 ID : 264330659165

Option 4 ID : 264330659163

Status : Answered

Chosen Option : 1

Comprehension:

In the following passage some words have been deleted. Read the passage carefully and select the most appropriate option to fill in each blank.

Fire is a significant factor in human (1)_____. The Stone Age man was the first to discover and use fire, which provided him (2)_____ and a means to cook food. Initially, he produced fire by rubbing two stones, and the (3)_____ between two stones generated fire. But this process was very (4)_____ and he wanted to discover a less laborious way of producing fire. For this he had to first preserve the fire. He discovered a fire band and carried it everywhere. This discovery led to the invention of torches and lamps that could be used for (5)_____, and preserving flame. So, we can say that fire is an accidental invention.

SubQuestion No : 83

Q.83 Select the most appropriate option to fill in blank number 3.

- Ans 1. cohesion
 2. retraction
 3. smoothness
 4. friction

Question ID : 264330168072

Option 1 ID : 264330659168

Option 2 ID : 264330659167

Option 3 ID : 264330659169

Option 4 ID : 264330659170

Status : Answered

Chosen Option : 4

Comprehension:

In the following passage some words have been deleted. Read the passage carefully and select the most appropriate option to fill in each blank.

Fire is a significant factor in human (1)_____. The Stone Age man was the first to discover and use fire, which provided him (2)_____ and a means to cook food. Initially, he produced fire by rubbing two stones, and the (3)_____ between two stones generated fire. But this process was very (4)_____ and he wanted to discover a less laborious way of producing fire. For this he had to first preserve the fire. He discovered a fire band and carried it everywhere. This discovery led to the invention of torches and lamps that could be used for (5)_____, and preserving flame. So, we can say that fire is an accidental invention.

SubQuestion No : 84

Q.84 Select the most appropriate option to fill in blank number 4.

- Ans 1. uncontainable
 2. controllable
 3. cumbersome
 4. manageable

Question ID : 264330168073

Option 1 ID : 264330659174

Option 2 ID : 264330659173

Option 3 ID : 264330659171

Option 4 ID : 264330659172

Status : Answered

Chosen Option : 1

Comprehension:

In the following passage some words have been deleted. Read the passage carefully and select the most appropriate option to fill in each blank.

Fire is a significant factor in human (1)_____. The Stone Age man was the first to discover and use fire, which provided him (2)_____ and a means to cook food. Initially, he produced fire by rubbing two stones, and the (3)_____ between two stones generated fire. But this process was very (4)_____ and he wanted to discover a less laborious way of producing fire. For this he had to first preserve the fire. He discovered a fire band and carried it everywhere. This discovery led to the invention of torches and lamps that could be used for (5)_____, and preserving flame. So, we can say that fire is an accidental invention.

SubQuestion No : 85

Q.85 Select the most appropriate option to fill in blank number 5.

- Ans 1. darkness
 2. dullness
 3. illumination
 4. confusion

Question ID : 264330168074

Option 1 ID : 264330659177

Option 2 ID : 264330659178

Option 3 ID : 264330659176

Option 4 ID : 264330659175

Status : Answered

Chosen Option : 3

Comprehension:

Read the given passage and answer the questions that follow.

Cybercrime refers to any illegal activity that involves the use of technology or computer networks. As technology continues to advance and more people depend on it for their daily lives, the threat of cybercrime becomes more prevalent. Cybercriminals can carry out various types of attacks, including hacking, phishing, ransomware attacks and identity theft.

One of the most common forms of cybercrime is hacking, where a cybercriminal gains unauthorised access to a computer system or network. This type of attack can be particularly devastating, as it can give the hacker access to sensitive information such as financial data, personal information or intellectual property. Cybercriminals can also use malware to infiltrate systems, steal information or cause damage to the network.

Phishing is another common form of cybercrime that involves tricking people into providing personal information or login credentials. Cybercriminals will often create fake websites or emails that look legitimate to convince users to give up their information. These attacks can be very effective because they often target people's trust in legitimate businesses or institutions.

Ransomware attacks have become increasingly prevalent in recent years, where cybercriminals use malware to lock a victim's computer or files until a ransom is paid. This type of attack can be particularly damaging for businesses, as it can result in lost revenue, damage to reputation and a disruption in operations.

Identity theft is another major form of cybercrime, where cybercriminals steal someone's personal information to access financial accounts, apply for credit or commit other crimes in their name. This can be particularly damaging for individuals, as it can take months or even years to fully recover from the damage.

Cybercrime is a global problem that affects individuals, businesses and governments alike. It can cause significant financial losses, damage to reputation and disruptions to daily life. To combat cybercrime, individuals and organisations must take proactive measures to protect themselves, including using strong passwords, keeping software up to date and being cautious when opening emails or clicking links.

Governments and law enforcement agencies also have a role to play in combatting cybercrime. They can work to strengthen cybersecurity laws, increase funding for cybersecurity initiatives and collaborate with international partners to investigate and prosecute cybercriminals.

Overall, cybercrime is a complex and ever-evolving problem requiring a multi-faceted approach. By taking proactive measures and working together, we can reduce the threat of cybercrime and protect ourselves and our communities from its damaging effects.

SubQuestion No : 86

Q.86 Which of the following best describes the tone of the passage?

- Ans
- 1. Humorous
 - 2. Sarcastic
 - 3. Informative
 - 4. Confrontational

Question ID : 264330166401

Option 1 ID : 264330652654

Option 2 ID : 264330652652

Option 3 ID : 264330652651

Option 4 ID : 264330652653

Status : Answered

Chosen Option : 3

Comprehension:

Read the given passage and answer the questions that follow.

Cybercrime refers to any illegal activity that involves the use of technology or computer networks. As technology continues to advance and more people depend on it for their daily lives, the threat of cybercrime becomes more prevalent. Cybercriminals can carry out various types of attacks, including hacking, phishing, ransomware attacks and identity theft.

One of the most common forms of cybercrime is hacking, where a cybercriminal gains unauthorised access to a computer system or network. This type of attack can be particularly devastating, as it can give the hacker access to sensitive information such as financial data, personal information or intellectual property. Cybercriminals can also use malware to infiltrate systems, steal information or cause damage to the network.

Phishing is another common form of cybercrime that involves tricking people into providing personal information or login credentials. Cybercriminals will often create fake websites or emails that look legitimate to convince users to give up their information. These attacks can be very effective because they often target people's trust in legitimate businesses or institutions.

Ransomware attacks have become increasingly prevalent in recent years, where cybercriminals use malware to lock a victim's computer or files until a ransom is paid. This type of attack can be particularly damaging for businesses, as it can result in lost revenue, damage to reputation and a disruption in operations.

Identity theft is another major form of cybercrime, where cybercriminals steal someone's personal information to access financial accounts, apply for credit or commit other crimes in their name. This can be particularly damaging for individuals, as it can take months or even years to fully recover from the damage.

Cybercrime is a global problem that affects individuals, businesses and governments alike. It can cause significant financial losses, damage to reputation and disruptions to daily life. To combat cybercrime, individuals and organisations must take proactive measures to protect themselves, including using strong passwords, keeping software up to date and being cautious when opening emails or clicking links.

Governments and law enforcement agencies also have a role to play in combatting cybercrime. They can work to strengthen cybersecurity laws, increase funding for cybersecurity initiatives and collaborate with international partners to investigate and prosecute cybercriminals.

Overall, cybercrime is a complex and ever-evolving problem requiring a multi-faceted approach. By taking proactive measures and working together, we can reduce the threat of cybercrime and protect ourselves and our communities from its damaging effects.

SubQuestion No : 87

Q.87 Which of the following are facts given in the passage?

- Ans**
- 1. Hacking is a type of cybercrime that can give hackers access to sensitive information.
 - 2. Cybercrime only affects individuals and not businesses.
 - 3. Phishing is a type of cybercrime that involves locking a victim's computer or files until a ransom is paid.
 - 4. Identity theft cannot result in significant financial losses.

Question ID : 264330166399

Option 1 ID : 264330652644

Option 2 ID : 264330652643

Option 3 ID : 264330652645

Option 4 ID : 264330652646

Status : Answered

Chosen Option : 1

Comprehension:

Read the given passage and answer the questions that follow.

Cybercrime refers to any illegal activity that involves the use of technology or computer networks. As technology continues to advance and more people depend on it for their daily lives, the threat of cybercrime becomes more prevalent. Cybercriminals can carry out various types of attacks, including hacking, phishing, ransomware attacks and identity theft.

One of the most common forms of cybercrime is hacking, where a cybercriminal gains unauthorised access to a computer system or network. This type of attack can be particularly devastating, as it can give the hacker access to sensitive information such as financial data, personal information or intellectual property. Cybercriminals can also use malware to infiltrate systems, steal information or cause damage to the network.

Phishing is another common form of cybercrime that involves tricking people into providing personal information or login credentials. Cybercriminals will often create fake websites or emails that look legitimate to convince users to give up their information. These attacks can be very effective because they often target people's trust in legitimate businesses or institutions.

Ransomware attacks have become increasingly prevalent in recent years, where cybercriminals use malware to lock a victim's computer or files until a ransom is paid. This type of attack can be particularly damaging for businesses, as it can result in lost revenue, damage to reputation and a disruption in operations.

Identity theft is another major form of cybercrime, where cybercriminals steal someone's personal information to access financial accounts, apply for credit or commit other crimes in their name. This can be particularly damaging for individuals, as it can take months or even years to fully recover from the damage.

Cybercrime is a global problem that affects individuals, businesses and governments alike. It can cause significant financial losses, damage to reputation and disruptions to daily life. To combat cybercrime, individuals and organisations must take proactive measures to protect themselves, including using strong passwords, keeping software up to date and being cautious when opening emails or clicking links.

Governments and law enforcement agencies also have a role to play in combatting cybercrime. They can work to strengthen cybersecurity laws, increase funding for cybersecurity initiatives and collaborate with international partners to investigate and prosecute cybercriminals.

Overall, cybercrime is a complex and ever-evolving problem requiring a multi-faceted approach. By taking proactive measures and working together, we can reduce the threat of cybercrime and protect ourselves and our communities from its damaging effects.

SubQuestion No : 88

Q.88 Which of the following can be inferred from the passage?

- Ans
- 1. Cybercrime is a problem that only affects individuals and businesses.
 - 2. Cybersecurity measures cannot alone prevent all forms of cybercrime.
 - 3. Ransomware attacks are the most common form of cybercrime.
 - 4. Cybercriminals use phishing attacks to gain access to financial information.

Question ID : 264330166400

Option 1 ID : 264330652647

Option 2 ID : 264330652650

Option 3 ID : 264330652648

Option 4 ID : 264330652649

Status : Answered

Chosen Option : 3

Comprehension:

Read the given passage and answer the questions that follow.

Cybercrime refers to any illegal activity that involves the use of technology or computer networks. As technology continues to advance and more people depend on it for their daily lives, the threat of cybercrime becomes more prevalent. Cybercriminals can carry out various types of attacks, including hacking, phishing, ransomware attacks and identity theft.

One of the most common forms of cybercrime is hacking, where a cybercriminal gains unauthorised access to a computer system or network. This type of attack can be particularly devastating, as it can give the hacker access to sensitive information such as financial data, personal information or intellectual property. Cybercriminals can also use malware to infiltrate systems, steal information or cause damage to the network.

Phishing is another common form of cybercrime that involves tricking people into providing personal information or login credentials. Cybercriminals will often create fake websites or emails that look legitimate to convince users to give up their information. These attacks can be very effective because they often target people's trust in legitimate businesses or institutions.

Ransomware attacks have become increasingly prevalent in recent years, where cybercriminals use malware to lock a victim's computer or files until a ransom is paid. This type of attack can be particularly damaging for businesses, as it can result in lost revenue, damage to reputation and a disruption in operations.

Identity theft is another major form of cybercrime, where cybercriminals steal someone's personal information to access financial accounts, apply for credit or commit other crimes in their name. This can be particularly damaging for individuals, as it can take months or even years to fully recover from the damage.

Cybercrime is a global problem that affects individuals, businesses and governments alike. It can cause significant financial losses, damage to reputation and disruptions to daily life. To combat cybercrime, individuals and organisations must take proactive measures to protect themselves, including using strong passwords, keeping software up to date and being cautious when opening emails or clicking links.

Governments and law enforcement agencies also have a role to play in combatting cybercrime. They can work to strengthen cybersecurity laws, increase funding for cybersecurity initiatives and collaborate with international partners to investigate and prosecute cybercriminals.

Overall, cybercrime is a complex and ever-evolving problem requiring a multi-faceted approach. By taking proactive measures and working together, we can reduce the threat of cybercrime and protect ourselves and our communities from its damaging effects.

SubQuestion No : 89

Q.89 Which of the following is the most appropriate title for the passage?

- Ans 1. Types of Cybercrime and Their Effects
2. The Global Problem of Cybercrime
3. The Role of Governments in Combatting Cybercrime
4. Cybersecurity Measures for Individuals and Organisations

Question ID : 264330166398

Option 1 ID : 264330652640

Option 2 ID : 264330652642

Option 3 ID : 264330652641

Option 4 ID : 264330652639

Status : Answered

Chosen Option : 1

Comprehension:

Read the given passage and answer the questions that follow.

Cybercrime refers to any illegal activity that involves the use of technology or computer networks. As technology continues to advance and more people depend on it for their daily lives, the threat of cybercrime becomes more prevalent. Cybercriminals can carry out various types of attacks, including hacking, phishing, ransomware attacks and identity theft.

One of the most common forms of cybercrime is hacking, where a cybercriminal gains unauthorised access to a computer system or network. This type of attack can be particularly devastating, as it can give the hacker access to sensitive information such as financial data, personal information or intellectual property. Cybercriminals can also use malware to infiltrate systems, steal information or cause damage to the network.

Phishing is another common form of cybercrime that involves tricking people into providing personal information or login credentials. Cybercriminals will often create fake websites or emails that look legitimate to convince users to give up their information. These attacks can be very effective because they often target people's trust in legitimate businesses or institutions.

Ransomware attacks have become increasingly prevalent in recent years, where cybercriminals use malware to lock a victim's computer or files until a ransom is paid. This type of attack can be particularly damaging for businesses, as it can result in lost revenue, damage to reputation and a disruption in operations.

Identity theft is another major form of cybercrime, where cybercriminals steal someone's personal information to access financial accounts, apply for credit or commit other crimes in their name. This can be particularly damaging for individuals, as it can take months or even years to fully recover from the damage.

Cybercrime is a global problem that affects individuals, businesses and governments alike. It can cause significant financial losses, damage to reputation and disruptions to daily life. To combat cybercrime, individuals and organisations must take proactive measures to protect themselves, including using strong passwords, keeping software up to date and being cautious when opening emails or clicking links.

Governments and law enforcement agencies also have a role to play in combatting cybercrime. They can work to strengthen cybersecurity laws, increase funding for cybersecurity initiatives and collaborate with international partners to investigate and prosecute cybercriminals.

Overall, cybercrime is a complex and ever-evolving problem requiring a multi-faceted approach. By taking proactive measures and working together, we can reduce the threat of cybercrime and protect ourselves and our communities from its damaging effects.

SubQuestion No : 90

Q.90 What is phishing ?

- Ans**
- 1. Phishing is a type of identity theft where cybercriminals steal someone's personal information to access financial accounts.
 - 2. Phishing involves tricking people into providing personal information or login credentials.
 - 3. Phishing involves hacking into a computer system and stealing sensitive information.
 - 4. Phishing is a type of malware that locks a victim's computer or files until a ransom is paid.

Question ID : 264330166402

Option 1 ID : 264330652658

Option 2 ID : 264330652657

Option 3 ID : 264330652655

Option 4 ID : 264330652656

Status : Answered

Chosen Option : 2

Comprehension:

Read the given passage and answer the question that follows.

Sustainable utensils are proving to be a crucial tool in our collective efforts towards building a greener and more environmentally conscious world. These utensils, often made from renewable resources such as bamboo or plant-based materials like cornstarch, offer a myriad of benefits. Firstly, sustainable utensils significantly reduce our reliance on single-use plastics. Plastic cutlery, traditionally used for convenience, contributes to the vast amounts of waste that end up in landfills and oceans, polluting ecosystems and harming marine life. By switching to sustainable alternatives, we can minimise this environmental damage. Secondly, sustainable utensils are biodegradable or compostable, meaning they can break down naturally over time. This ensures that even if they do end up in landfills, they won't persist for centuries like plastic does. Instead, they return to the Earth without leaving a lasting negative impact. These utensils can be reused multiple times, further reducing waste. Many sustainable options are durable and washable, making them a viable long-term solution.

SubQuestion No : 91**Q.91 Which materials are commonly used to make sustainable utensils?**

- Ans 1. Plastic and aluminium
2. Bamboo and cornstarch
3. Metal and glass
4. Ceramic and wood

Question ID : 264330169891

Option 1 ID : 264330666242

Option 2 ID : 264330666241

Option 3 ID : 264330666239

Option 4 ID : 264330666240

Status : Answered

Chosen Option : 2

Comprehension:

Read the given passage and answer the question that follows.

Sustainable utensils are proving to be a crucial tool in our collective efforts towards building a greener and more environmentally conscious world. These utensils, often made from renewable resources such as bamboo or plant-based materials like cornstarch, offer a myriad of benefits. Firstly, sustainable utensils significantly reduce our reliance on single-use plastics. Plastic cutlery, traditionally used for convenience, contributes to the vast amounts of waste that end up in landfills and oceans, polluting ecosystems and harming marine life. By switching to sustainable alternatives, we can minimise this environmental damage. Secondly, sustainable utensils are biodegradable or compostable, meaning they can break down naturally over time. This ensures that even if they do end up in landfills, they won't persist for centuries like plastic does. Instead, they return to the Earth without leaving a lasting negative impact. These utensils can be reused multiple times, further reducing waste. Many sustainable options are durable and washable, making them a viable long-term solution.

SubQuestion No : 92**Q.92 What is the main focus of the passage?**

- Ans 1. The benefits and harms of single-use plastic
2. The importance of sustainable alternatives
3. The environmental benefits of the sustainable utensils
4. The economic benefits of sustainable utensils

Question ID : 264330169890

Option 1 ID : 264330666238

Option 2 ID : 264330666235

Option 3 ID : 264330666236

Option 4 ID : 264330666237

Status : Answered

Chosen Option : 1

Comprehension:

Read the given passage and answer the question that follows.

Sustainable utensils are proving to be a crucial tool in our collective efforts towards building a greener and more environmentally conscious world. These utensils, often made from renewable resources such as bamboo or plant-based materials like cornstarch, offer a myriad of benefits. Firstly, sustainable utensils significantly reduce our reliance on single-use plastics. Plastic cutlery, traditionally used for convenience, contributes to the vast amounts of waste that end up in landfills and oceans, polluting ecosystems and harming marine life. By switching to sustainable alternatives, we can minimise this environmental damage. Secondly, sustainable utensils are biodegradable or compostable, meaning they can break down naturally over time. This ensures that even if they do end up in landfills, they won't persist for centuries like plastic does. Instead, they return to the Earth without leaving a lasting negative impact. These utensils can be reused multiple times, further reducing waste. Many sustainable options are durable and washable, making them a viable long-term solution.

SubQuestion No : 93

Q.93 Based on the information provided in the passage, which among the following is NOT an example of sustainable utensil?

- Ans
- 1. Wooden cutlery
 - 2. Edible cutlery
 - 3. Plastic cutlery
 - 4. Bioplastic cutlery

Question ID : 264330169894

Option 1 ID : 264330666251

Option 2 ID : 264330666253

Option 3 ID : 264330666254

Option 4 ID : 264330666252

Status : Answered

Chosen Option : 3

Comprehension:

Read the given passage and answer the question that follows.

Sustainable utensils are proving to be a crucial tool in our collective efforts towards building a greener and more environmentally conscious world. These utensils, often made from renewable resources such as bamboo or plant-based materials like cornstarch, offer a myriad of benefits. Firstly, sustainable utensils significantly reduce our reliance on single-use plastics. Plastic cutlery, traditionally used for convenience, contributes to the vast amounts of waste that end up in landfills and oceans, polluting ecosystems and harming marine life. By switching to sustainable alternatives, we can minimise this environmental damage. Secondly, sustainable utensils are biodegradable or compostable, meaning they can break down naturally over time. This ensures that even if they do end up in landfills, they won't persist for centuries like plastic does. Instead, they return to the Earth without leaving a lasting negative impact. These utensils can be reused multiple times, further reducing waste. Many sustainable options are durable and washable, making them a viable long-term solution.

SubQuestion No : 94

Q.94 What distinguishes sustainable utensils from plastic cutlery?

- Ans
- 1. They are more expensive
 - 2. They have a lower environmental impact
 - 3. They have a shorter lifespan
 - 4. They are made from non-renewable resources

Question ID : 264330169892

Option 1 ID : 264330666243

Option 2 ID : 264330666246

Option 3 ID : 264330666245

Option 4 ID : 264330666244

Status : Answered

Chosen Option : 4

Comprehension:

Read the given passage and answer the question that follows.

Sustainable utensils are proving to be a crucial tool in our collective efforts towards building a greener and more environmentally conscious world. These utensils, often made from renewable resources such as bamboo or plant-based materials like cornstarch, offer a myriad of benefits. Firstly, sustainable utensils significantly reduce our reliance on single-use plastics. Plastic cutlery, traditionally used for convenience, contributes to the vast amounts of waste that end up in landfills and oceans, polluting ecosystems and harming marine life. By switching to sustainable alternatives, we can minimise this environmental damage. Secondly, sustainable utensils are biodegradable or compostable, meaning they can break down naturally over time. This ensures that even if they do end up in landfills, they won't persist for centuries like plastic does. Instead, they return to the Earth without leaving a lasting negative impact. These utensils can be reused multiple times, further reducing waste. Many sustainable options are durable and washable, making them a viable long-term solution.

SubQuestion No : 95

Q.95 Which of the following is NOT a characteristic of sustainable utensils?

Ans 1. Biodegradability

2. Non-recyclability

3. Durability

4. Reusability

Question ID : 264330169893

Option 1 ID : 264330666247

Option 2 ID : 264330666248

Option 3 ID : 264330666249

Option 4 ID : 264330666250

Status : Answered

Chosen Option : 2

Comprehension:

Read the given passage and answer the questions that follow.

In a study, the University of Colorado in Denver observed a group of nurses who visited pregnant mothers. After the women gave birth, the nurses made approximately twenty visits before the children turned two years old. When the benefits to the children were studied, the researchers found that the children were emotionally less vulnerable to fear. The children learned languages sooner. They also had higher mental development scores than the control group without the nurses' support. The benefits to the children because of this simple intervention of the nurses' support were observed even fifteen years later.

SubQuestion No : 96

**Q.96 Select the most appropriate ANTONYM of the given word.
Unsusceptible**

Ans 1. Approximately

2. Intervention

3. Development

4. Vulnerable

Question ID : 264330167935

Option 1 ID : 264330658643

Option 2 ID : 264330658646

Option 3 ID : 264330658645

Option 4 ID : 264330658644

Status : Answered

Chosen Option : 2

Comprehension:

Read the given passage and answer the questions that follow.

In a study, the University of Colorado in Denver observed a group of nurses who visited pregnant mothers. After the women gave birth, the nurses made approximately twenty visits before the children turned two years old. When the benefits to the children were studied, the researchers found that the children were emotionally less vulnerable to fear. The children learned languages sooner. They also had higher mental development scores than the control group without the nurses' support. The benefits to the children because of this simple intervention of the nurses' support were observed even fifteen years later.

SubQuestion No : 97**Q.97 What is the style of the passage?**

- Ans 1. Expository
 2. Classification
 3. Descriptive
 4. Narrative

Question ID : 264330167934

Option 1 ID : 264330658642

Option 2 ID : 264330658641

Option 3 ID : 264330658640

Option 4 ID : 264330658639

Status : Answered

Chosen Option : 1

Comprehension:

Read the given passage and answer the questions that follow.

In a study, the University of Colorado in Denver observed a group of nurses who visited pregnant mothers. After the women gave birth, the nurses made approximately twenty visits before the children turned two years old. When the benefits to the children were studied, the researchers found that the children were emotionally less vulnerable to fear. The children learned languages sooner. They also had higher mental development scores than the control group without the nurses' support. The benefits to the children because of this simple intervention of the nurses' support were observed even fifteen years later.

SubQuestion No : 98**Q.98 What is the most suitable title of the passage?**

- Ans 1. Social Support and its Benefits
 2. Intervention of the Nurses
 3. Pregnant Mothers and Nurses
 4. Control Group and Nurses

Question ID : 264330167932

Option 1 ID : 264330658633

Option 2 ID : 264330658632

Option 3 ID : 264330658631

Option 4 ID : 264330658634

Status : Answered

Chosen Option : 2

Comprehension:

Read the given passage and answer the questions that follow.

In a study, the University of Colorado in Denver observed a group of nurses who visited pregnant mothers. After the women gave birth, the nurses made approximately twenty visits before the children turned two years old. When the benefits to the children were studied, the researchers found that the children were emotionally less vulnerable to fear. The children learned languages sooner. They also had higher mental development scores than the control group without the nurses' support. The benefits to the children because of this simple intervention of the nurses' support were observed even fifteen years later.

SubQuestion No : 99**Q.99 What can one infer from the passage?**

- Ans** ✓ 1. The community plays an important role in offering social support to mothers.
- ✗ 2. Some children learn languages quickly.
- ✗ 3. Control group without nurses' support have relatively elevated mental development.
- ✗ 4. Nurses' intervention reduce vulnerability to fear in pregnant mothers.

Question ID : 264330167936

Option 1 ID : 264330658648

Option 2 ID : 264330658647

Option 3 ID : 264330658649

Option 4 ID : 264330658650

Status : Answered

Chosen Option : 1

Comprehension:

Read the given passage and answer the questions that follow.

In a study, the University of Colorado in Denver observed a group of nurses who visited pregnant mothers. After the women gave birth, the nurses made approximately twenty visits before the children turned two years old. When the benefits to the children were studied, the researchers found that the children were emotionally less vulnerable to fear. The children learned languages sooner. They also had higher mental development scores than the control group without the nurses' support. The benefits to the children because of this simple intervention of the nurses' support were observed even fifteen years later.

SubQuestion No : 100**Q.100 Which statement best summarises the passage?**

- Ans** ✓ 1. Community support is vital in the emotional development of a child.
- ✗ 2. Study on nurses have impact even after fifteen years.
- ✗ 3. Nurses should visit pregnant mothers regularly.
- ✗ 4. Pregnant women are emotionally less vulnerable to fear.

Question ID : 264330167933

Option 1 ID : 264330658636

Option 2 ID : 264330658638

Option 3 ID : 264330658635

Option 4 ID : 264330658637

Status : Answered

Chosen Option : 1

Stenographer Grade C and D Examination 2023

Roll Number	
Candidate Name	
Venue Name	iON Digital Zone iDZ Naino Ka Bas
Exam Date	12/10/2023
Exam Time	12:30 PM - 2:30 PM
Subject	Stenographer Grade C and D Examination 2023

Section : General Intelligence and Reasoning

Q.1 निम्नलिखित में से कौन-सी संख्या दी गई श्रृंखला में प्रश्न-चिह्न (?) को प्रतिस्थापित करेगी?
2, 9, 37, 149, ?, 2389

Ans ✓ 1. 597

✗ 2. 646

✗ 3. 542

✗ 4. 648

Question ID : 264330112579

Option 1 ID : 264330442403

Option 2 ID : 264330442401

Option 3 ID : 264330442402

Option 4 ID : 264330442404

Status : Answered

Chosen Option : 1

Prepare 50% Faster

Q.2 दिए गए विकल्पों में से उस आकृति का चयन करें, जो निम्नलिखित शृंखला में

प्रश्नचिह्न (?) को प्रतिस्थापित करेगी।

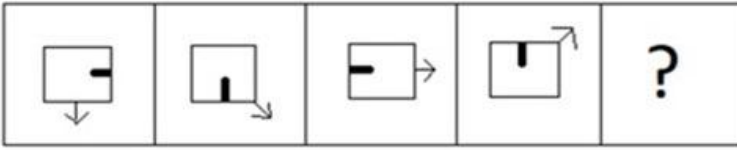

Ans

✗ 1.

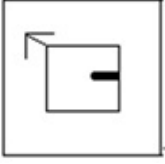

✓ 2.

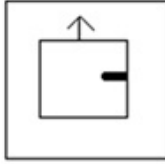

✗ 3.

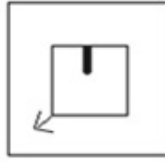

✗ 4.

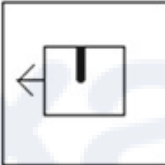

Question ID : 26433087159

Option 1 ID : 264330342273

Option 2 ID : 264330342275

Option 3 ID : 264330342276

Option 4 ID : 264330342274

Status : Answered

Chosen Option : 2

Q.3 दिए गए विकल्पों में से उस संख्या का चयन कीजिए, जो निम्नलिखित शृंखला में प्रश्न-चिह्न (?) को प्रतिस्थापित कर सकती है।
3360, 4080, ?, 5814

Ans ✓ 1. 4896

✗ 2. 5090

✗ 3. 4913

✗ 4. 4930

Question ID : 26433089529

Option 1 ID : 264330351618

Option 2 ID : 264330351620

Option 3 ID : 264330351617

Option 4 ID : 264330351619

Status : Answered

Chosen Option : 1

Q.4 यदि '+' का अर्थ '+', '-' का अर्थ '+', 'x' का अर्थ '-' और '÷' का अर्थ 'x' है, तो निम्नलिखित समीकरण में प्रश्न चिह्न (?) के स्थान पर क्या आएगा?

$$49 - 6 \div 4 + 2 \times 14 = ?$$

- Ans
- 1. 53
 - 2. 47
 - 3. 33
 - 4. 39

Question ID : 264330101104
 Option 1 ID : 264330396961
 Option 2 ID : 264330396962
 Option 3 ID : 264330396963
 Option 4 ID : 264330396964
 Status : Answered
 Chosen Option : 2

Q.5 A, B की बहू है। E, A का भाई है। B का केवल एक पुत्र, C है। यदि D, C का पुत्र है, तो D, A से किस प्रकार संबंधित है?

- Ans
- 1. पुत्र
 - 2. भाई
 - 3. बहू
 - 4. पौत्र

Question ID : 26433099145
 Option 1 ID : 264330389193
 Option 2 ID : 264330389195
 Option 3 ID : 264330389196
 Option 4 ID : 264330389194
 Status : Answered
 Chosen Option : 1

Q.6 दर्पण को नीचे दर्शाए अनुसार MN पर रखे जाने पर दिए गए संयोजन की सही दर्पण छवि का चयन कीजिए।

Ge492a

M
|
N

- Ans
- 1. a 2 e 4 9 2 e
 - 2. 6 2 e 4 9 2
 - 3. 6 2 e 4 9 2
 - 4. 6 7 6 4 9 2

Question ID : 264330109215
 Option 1 ID : 264330429138
 Option 2 ID : 264330429140
 Option 3 ID : 264330429139
 Option 4 ID : 264330429137
 Status : Answered
 Chosen Option : 2

Q.7 उस विकल्प का चयन कीजिए जो नीचे दिए गए शब्दों के उस सही क्रम को दर्शाता है, जिस क्रम में वे अंग्रेजी शब्दकोश में आएंगे।

1. Mitochondria
2. Miticidal
3. Mitigative
4. Mitogenic
5. Mitotically
6. Mitosis

- Ans
- 1. 2, 1, 3, 6, 4, 5
 - 2. 3, 2, 1, 4, 6, 5
 - 3. 2, 3, 1, 6, 4, 5
 - 4. 2, 3, 1, 4, 6, 5

Question ID : 264330144929
Option 1 ID : 264330567973
Option 2 ID : 264330567974
Option 3 ID : 264330567972
Option 4 ID : 264330567971
Status : Answered
Chosen Option : 4

Q.8 नीचे एक कथन दिया गया है जिसके बाद दो निष्कर्ष I और II दिए गए हैं। कथन का ध्यानपूर्वक अध्ययन करें और निर्धारित करें कि कौन सा/से निष्कर्ष निश्चित रूप से सत्य है/हैं।

कथन: $A \geq B \geq C = D < E$; $F \leq C > G$

निष्कर्ष I: $A \geq F$

निष्कर्ष II: $D > G$

- Ans
- 1. न तो निष्कर्ष I सत्य है और न ही II सत्य है।
 - 2. केवल निष्कर्ष I सत्य है।
 - 3. निष्कर्ष I और II दोनों सत्य हैं।
 - 4. केवल निष्कर्ष II सत्य है।

Question ID : 264330131075
Option 1 ID : 264330513414
Option 2 ID : 264330513411
Option 3 ID : 264330513413
Option 4 ID : 264330513412
Status : Answered
Chosen Option : 2

Q.9 निम्नलिखित में से उस समुच्चय का चयन कीजिए, जिसमें संख्याएँ उसी प्रकार से संबंधित हैं, जिस प्रकार दिए गए समुच्चय की संख्याएँ संबंधित हैं।

(नोट: संख्याओं को उसके घटक अंकों में विभाजित किए बिना, पूर्ण संख्याओं पर ही गणितीय संक्रियाएँ की जानी चाहिए। जैसे 13 - मान लीजिए 13 पर गणितीय संक्रियाएँ जैसे कि 13 में जोड़ना/घटाना/गुणा करना आदि किया जा सकता है। 13 को 1 और 3 में तोड़कर और फिर 1 और 3 पर गणितीय संक्रियाएँ करने की अनुमति नहीं है।)

(25, 30, 65)

(50, 50, 100)

- Ans
- 1. (45, 40, 75)
 - 2. (25, 132, 18)
 - 3. (35, 178, 15)
 - 4. (44, 157, 14)

Question ID : 26433083125
Option 1 ID : 264330326333
Option 2 ID : 264330326335
Option 3 ID : 264330326336
Option 4 ID : 264330326334
Status : Answered
Chosen Option : 1

Q.10 दिए गए विकल्पों में से उस संख्या का चयन कीजिए जो निम्नलिखित श्रृंखला में प्रश्न चिह्न (?) के स्थान पर आ सकती है।
4, 16, 64, 256, ?

- Ans 1. 512
 2. 768
 3. 1024
 4. 986

Question ID : 264330112660
Option 1 ID : 264330442725
Option 2 ID : 264330442726
Option 3 ID : 264330442728
Option 4 ID : 264330442727
Status : Answered
Chosen Option : 3

Q.11 दिए गए समीकरण को संतुलित करने के लिए किन दो संख्याओं (अंकों को नहीं) को परस्पर बदलना होगा?
 $(3 \times 16) \div 8 + 124 \div 2 - 64 \div (2 \times 4) = 84$

- Ans 1. 64 और 124
 2. 8 और 16
 3. 2 और 3
 4. 16 और 64

Question ID : 264330106670
Option 1 ID : 264330418981
Option 2 ID : 264330418982
Option 3 ID : 264330418983
Option 4 ID : 264330418984
Status : Answered
Chosen Option : 4

Q.12 दी गई श्रृंखला को पूरा करने के लिए कौन-सा अक्षर-समूह प्रश्न चिह्न (?) को प्रतिस्थापित करेगा?
RWIC, OUFG, ?, IQZO, FOWS

- Ans 1. LTDK
 2. LTCK
 3. LTDJ
 4. LSCK

Question ID : 26433067966
Option 1 ID : 264330266378
Option 2 ID : 264330266377
Option 3 ID : 264330266379
Option 4 ID : 264330266376
Status : Answered
Chosen Option : 4

Q.13 उस विकल्प का चयन करें जो तीसरे शब्द से उसी प्रकार संबंधित है जिस प्रकार दूसरा शब्द पहले शब्द से संबंधित है।
हैरो : माली :: स्कैलपल : ?

- Ans
- 1. बावर्ची
 - 2. शिक्षक
 - 3. शल्य चिकित्सक
 - 4. पायलट

Question ID : 26433082754

Option 1 ID : 264330324851

Option 2 ID : 264330324849

Option 3 ID : 264330324850

Option 4 ID : 264330324852

Status : Answered

Chosen Option : 1

ixamBee

Prepare 50% Faster

Q.14 कागज के एक टुकड़े को मोड़ने का क्रम और मोड़े गए कागज को काटने का ढंग नीचे दर्शाया गया है। उस आकृति का चयन करें, जो कागज के खुले हुए रूप से सबसे अधिक मिलती-जुलती हो।

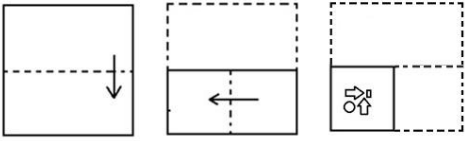

Ans

✓ 1.

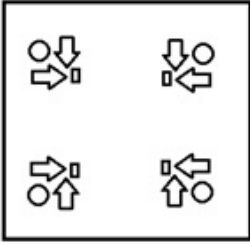

✗ 2.

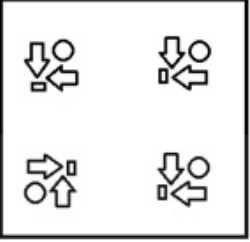

✗ 3.



✗ 4.

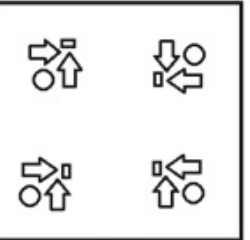

Question ID : 264330103218

Option 1 ID : 264330405179

Option 2 ID : 264330405180

Option 3 ID : 264330405177

Option 4 ID : 264330405178

Status : Answered

Chosen Option : 1

Q.15 निम्नलिखित में से कौन-सी संख्या दी गई श्रृंखला में प्रश्न चिह्न (?) को प्रतिस्थापित करेगी?
191, 534, 318, 443, ?

- Ans 1. 248
 2. 413
 3. 379
 4. 420

Question ID : 26433082434
Option 1 ID : 264330323571
Option 2 ID : 264330323570
Option 3 ID : 264330323572
Option 4 ID : 264330323569
Status : Answered
Chosen Option : 3

Q.16 उस समुच्चय का चयन करें जिसमें दी गई संख्याएं आपस में उसी प्रकार संबंधित हैं, जिस प्रकार प्रश्न में दिए गए समुच्चय की संख्याएं आपस में संबंधित हैं।
(नोट: संख्याओं को उसके घटक अंकों में विभाजित किए बिना, पूर्ण संख्याओं पर ही गणितीय संक्रियाएँ की जानी चाहिए। जैसे 13 - मान लीजिए 13 पर गणितीय संक्रियाएँ जैसे कि 13 में जोड़ना/घटाना/गुणा करना आदि किया जा सकता है। 13 को 1 और 3 में तोड़कर और फिर 1 और 3 पर गणितीय संक्रियाएँ करने की अनुमति नहीं है।)
(7, 32, 28)
(2, 12, 8)

- Ans 1. (8, 45, 40)
 2. (5, 25, 20)
 3. (3, 15, 12)
 4. (12, 52, 48)

Question ID : 26433087037
Option 1 ID : 264330341790
Option 2 ID : 264330341792
Option 3 ID : 264330341789
Option 4 ID : 264330341791
Status : Answered
Chosen Option : 4

Q.17 उस विकल्प का चयन कीजिए जो दिए गए शब्दों की सही व्यवस्था को तार्किक और सार्थक क्रम में दर्शाता है।
1. लुग्दी
2. कागज
3. नोटबुक
4. वृक्ष
5. स्टेशनरी दुकान

- Ans 1. 4 1 2 3 5
 2. 1 4 2 5 3
 3. 2 1 4 3 5
 4. 3 4 1 5 2

Question ID : 264330135334
Option 1 ID : 264330530245
Option 2 ID : 264330530243
Option 3 ID : 264330530244
Option 4 ID : 264330530246
Status : Answered
Chosen Option : 1

Q.18 निम्नलिखित में से कौन-सी संख्या, दी गई श्रृंखला में प्रश्नचिह्न (?) को प्रतिस्थापित करेगी?
17, 39, 43, 65, ?, 91

- Ans
- 1. 67
 - 2. 69
 - 3. 75
 - 4. 73

Question ID : 264330102154
Option 1 ID : 264330401084
Option 2 ID : 264330401081
Option 3 ID : 264330401082
Option 4 ID : 264330401083
Status : Answered
Chosen Option : 2

Q.19 तीन कथनों के बाद चार निष्कर्ष I, II, III और IV दिए गए हैं। कथनों को सत्य मानते हुए, भले ही वे सामान्य रूप से ज्ञात तथ्यों से भिन्न प्रतीत होते हों, निर्णय लीजिए कि कौन सा/से निष्कर्ष कथनों का तार्किक रूप से अनुसरण करता है/करते हैं।

कथन:

- कुछ चेयर, होल्डर हैं।
- कुछ होल्डर, बोतल हैं।
- कुछ बोतल, चेयर हैं।

निष्कर्ष:

- I. सभी चेयर, बोतल हैं।
- II. सभी बोतल, चेयर हैं।
- III. सभी होल्डर, बोतल हैं।
- IV. सभी होल्डर, चेयर हैं।

- Ans
- 1. निष्कर्ष II और III दोनों अनुसरण करते हैं।
 - 2. कोई निष्कर्ष अनुसरण नहीं करता है।
 - 3. निष्कर्ष I और II दोनों अनुसरण करते हैं।
 - 4. निष्कर्ष III और IV दोनों अनुसरण करते हैं।

Question ID : 26433093159
Option 1 ID : 264330365890
Option 2 ID : 264330365892
Option 3 ID : 264330365889
Option 4 ID : 264330365891
Status : Answered
Chosen Option : 2

Q.20 उस विकल्प का चयन करें जो उन अक्षरों का प्रतिनिधित्व करता है, जिन्हें नीचे दिए गए रिक्त स्थानों में क्रमिक रूप से बाएं से दाएं रखे जाने पर अक्षर श्रृंखला पूर्ण हो जाएगी।

CM __ LC _ ENL _ ME __ C __ NL

- Ans
- 1. ENMCNLME
 - 2. EMNCNLME
 - 3. ENMCLNME
 - 4. ENMLNCME

Question ID : 26433089994
Option 1 ID : 264330353454
Option 2 ID : 264330353455
Option 3 ID : 264330353453
Option 4 ID : 264330353456
Status : Answered
Chosen Option : 1

Q.21 दो कथनों के बाद दो निष्कर्ष I और II दिए गए हैं। कथनों को सत्य मानते हुए, भले ही वे सामान्य रूप से ज्ञात तथ्यों से भिन्न प्रतीत होते हों, निर्णय लीजिए कि कौन सा/से निष्कर्ष कथनों का तार्किक रूप से अनुसरण करता/करते है/हैं।

कथन:

समस्त काला, सफेद है।

कुछ सफेद, स्लेटी है।

निष्कर्ष:

I. कुछ स्लेटी, काला है।

II. कुछ सफेद, काला है।

Ans 1. न तो निष्कर्ष I अनुसरण करता है और न ही II अनुसरण करता है

2. केवल निष्कर्ष II अनुसरण करता है

3. निष्कर्ष I और II दोनों अनुसरण करते हैं

4. केवल निष्कर्ष I अनुसरण करता है

Question ID : 264330144955

Option 1 ID : 264330568078

Option 2 ID : 264330568076

Option 3 ID : 264330568077

Option 4 ID : 264330568075

Status : Answered

Chosen Option : 2

Q.22 यदि '+' का अर्थ 'x', '-' का अर्थ '÷', '÷' का अर्थ '+', और 'x' का अर्थ '-' है, तो निम्नलिखित व्यंजक का मान ज्ञात करें।

$$19 + 72 - 3 \times 56 \div 65 = ?$$

Ans 1. 397

2. 465

3. 425

4. 401

Question ID : 264330130352

Option 1 ID : 264330510520

Option 2 ID : 264330510522

Option 3 ID : 264330510521

Option 4 ID : 264330510519

Status : Answered

Chosen Option : 2

Q.23 उस विकल्प का चयन करें, जो छठी संख्या से उसी प्रकार संबंधित है, जिस प्रकार पहली संख्या दूसरी संख्या से और तीसरी संख्या चौथी संख्या से संबंधित है।
399 : 7 :: 584 : 8 :: ? : 11

Ans 1. 110

2. 1221

3. 1583

4. 1463

Question ID : 26433087211

Option 1 ID : 264330342481

Option 2 ID : 264330342482

Option 3 ID : 264330342484

Option 4 ID : 264330342483

Status : Answered

Chosen Option : 4

Q.24 A, B, C, D, E, F और G अलग-अलग लंबाई के हैं। B, F से लंबा है, लेकिन A और G दोनों से छोटा है। A केवल E से छोटा है। C केवल D से लंबा है। निम्नलिखित में से कौन G से लंबा है?

- Ans 1. F
 2. E
 3. C
 4. D

Question ID : 264330131658

Option 1 ID : 264330515734

Option 2 ID : 264330515731

Option 3 ID : 264330515732

Option 4 ID : 264330515733

Status : Answered

Chosen Option : 2

Q.25 अनुराग और भावना ने एक ही जगह से झाड़ू बनाना शुरू करते हैं। अनुराग ने उत्तर की ओर 11 km झाड़ू बनाया, फिर दाएं मुड़ जाता है और 13 km की दूरी तय करता है। भावना पश्चिम की ओर जाती है और 15 km की दूरी तय करती है, फिर दाएं मुड़ जाती है और 11 km की दूरी तय करती है। एक सीधी रेखा में वे एक दूसरे से कितनी दूर हैं?

- Ans 1. 50 km
 2. 52 km
 3. 28 km
 4. 26 km

Question ID : 264330132107

Option 1 ID : 264330517523

Option 2 ID : 264330517526

Option 3 ID : 264330517525

Option 4 ID : 264330517524

Status : Answered

Chosen Option : 3

ixamBee

Prepare 50% Faster

Q.26 निम्नांकित श्रृंखला में पैटर्न को जारी रखने के लिए प्रश्नचिह्न (?) को किस आकृति द्वारा प्रतिस्थापित किया जाना चाहिए?

B	7	O	1	
△ O	1 △	△ B	7 △	?
1 7 S S	B O	7 1 S S	O B	

Ans

✓ 1.

B		
△ O		
1 7 S		

✗ 2.

S		
△ O		
B 7 1		

✗ 3.

S		
O 7		
1 B △		

✗ 4.

O		
1 B		
△ 7 S		

Question ID : 264330129607

Option 1 ID : 264330507797

Option 2 ID : 264330507794

Option 3 ID : 264330507795

Option 4 ID : 264330507796

Status : Answered

Chosen Option : 1

Q.27 14 फरवरी 2022 को सोमवार था। 14 फरवरी 2020 को सप्ताह का कौन-सा दिन था?

Ans ✓ 1. शुक्रवार

✗ 2. गुरुवार

✗ 3. शनिवार

✗ 4. बुधवार

Question ID : 264330144941

Option 1 ID : 264330568020

Option 2 ID : 264330568019

Option 3 ID : 264330568022

Option 4 ID : 264330568021

Status : Not Answered

Chosen Option : --

Q.28 A, B, C, D, E, F, G और H एक वर्गाकार मेज के परितः मेज के केंद्र की ओर मुख करके बैठे हुए हैं। उनमें से कुछ मेज कोनों पर बैठे हैं, जबकि कुछ भुजाओं के ठीक मध्य में बैठे हैं। A, C के दाईं ओर तीसरे स्थान पर बैठा है। H, B और G के बीच में बैठा है। F, C के दाईं ओर दूसरे स्थान पर बैठा है। D किसी भी कोने पर नहीं बैठा है। G, D के दाईं ओर तीसरे स्थान पर बैठा है। D और C के बीच तीन व्यक्ति बैठे हैं।

B के बाईं ओर दूसरे स्थान पर कौन बैठा है?

- Ans
- 1. H
 - 2. A
 - 3. E
 - 4. D

Question ID : 26433090983
 Option 1 ID : 264330357341
 Option 2 ID : 264330357342
 Option 3 ID : 264330357344
 Option 4 ID : 264330357343
 Status : Answered
 Chosen Option : 2

Q.29 उस विकल्प आकृति का चयन करें, जिसमें दी गई आकृति सन्निकित है (घुमाने की अनुमति नहीं है)।



Ans

1.

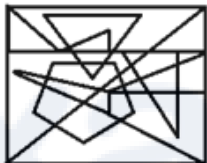

2.



3.

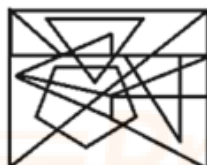

4.

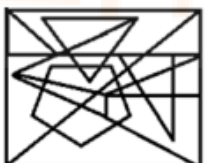

Question ID : 264330129589
 Option 1 ID : 264330507722
 Option 2 ID : 264330507725
 Option 3 ID : 264330507724
 Option 4 ID : 264330507723
 Status : Answered
 Chosen Option : 3

Q.30 तीन कथनों के बाद तीन निष्कर्ष I, II और III दिए गए हैं। कथनों को सत्य मानते हुए, भले ही वे सामान्य रूप से ज्ञात तथ्यों से भिन्न प्रतीत होते हों, निर्धारित करें कि कौन-सा/से निष्कर्ष कथनों का तार्किक रूप से अनुसरण करता है/करते हैं।

कथन:

कोई भी नदी समुद्र नहीं है।

कुछ नदियां झीलें हैं।

सभी नदियां तालाब हैं।

निष्कर्ष:

I. कुछ झीलें समुद्र हैं।

II. कुछ तालाब समुद्र हैं।

III. कुछ झीलें तालाब हैं।

Ans 1. केवल निष्कर्ष I और III अनुसरण करते हैं।

2. सभी निष्कर्ष अनुसरण करते हैं।

3. केवल निष्कर्ष III अनुसरण करता है।

4. केवल निष्कर्ष II और III अनुसरण करते हैं।

Question ID : 264330144917

Option 1 ID : 264330567924

Option 2 ID : 264330567926

Option 3 ID : 264330567923

Option 4 ID : 264330567925

Status : Answered

Chosen Option : 3

Q.31 दिए गए समीकरण को संतुलित करने के लिए किन दो चिह्नों को परस्पर बदलना होगा?

$$286 \div 13 \times 2 + 50 - 6 = 0$$

Ans 1. - और \times

2. + और \times

3. + और -

4. + और \times

Question ID : 264330144854

Option 1 ID : 264330567674

Option 2 ID : 264330567673

Option 3 ID : 264330567672

Option 4 ID : 264330567671

Status : Answered

Chosen Option : 3

Q.32 दस व्यक्ति दो समानांतर पंक्तियों में बैठे हैं, जहाँ प्रत्येक में 5 व्यक्ति इस प्रकार हैं कि अगल-बगल के व्यक्तियों के बीच समान दूरी है।

पंक्ति 1 में - A, B, C, D और E बैठे हैं और उन सभी का मुख दक्षिण की ओर है।

पंक्ति 2 में - P, Q, R, S और T बैठे हैं और उन सभी का मुख उत्तर की ओर है।

इस प्रकार प्रत्येक व्यक्ति दूसरी पंक्ति के किसी एक व्यक्ति की ओर अभिमुख है।

B, A के दाएँ से तीसरे स्थान पर बैठा है। P, A के निकटतम पड़ोसी की ओर अभिमुख है। R, P के बाएँ से तीसरे स्थान पर बैठा है। D, उस व्यक्ति के बाएँ से दूसरे स्थान पर बैठा है, जो T की ओर अभिमुख है।

D पंक्ति के किसी भी अंतिम छोर पर नहीं बैठा है। C, Q की ओर अभिमुख है।

E की ओर कौन अभिमुख है।

Ans 1. T

2. R

3. S

4. P

Question ID : 264330131652

Option 1 ID : 264330515707

Option 2 ID : 264330515708

Option 3 ID : 264330515710

Option 4 ID : 264330515709

Status : Not Answered

Chosen Option : --

Q.33 तीन कथनों के बाद तीन निष्कर्ष I, II और III दिए गए हैं। कथनों को सत्य मानते हुए, भले ही वे सामान्य रूप से ज्ञात तथ्यों से भिन्न प्रतीत होते हों, निर्धारित करें कि कौन-सा/से निष्कर्ष कथनों का तार्किक रूप से अनुसरण करता है/करते हैं।

कथन:
सभी सेब अनन्नास हैं।
कुछ सेब आम हैं।
कोई भी आम अंगूर नहीं है।

निष्कर्ष:
I. कुछ अनन्नास अंगूर नहीं हैं।
II. कोई भी अनन्नास अंगूर नहीं है।
III. कुछ सेब अंगूर नहीं हैं।

- Ans 1. केवल निष्कर्ष II और III अनुसरण करते हैं।
 2. केवल निष्कर्ष I और III अनुसरण करते हैं।
 3. केवल निष्कर्ष I और II अनुसरण करते हैं।
 4. सभी निष्कर्ष अनुसरण करते हैं।

Question ID : 264330144936

Option 1 ID : 264330568000

Option 2 ID : 264330568001

Option 3 ID : 264330567999

Option 4 ID : 264330568002

Status : Answered

Chosen Option : 2

Q.34 निम्नलिखित चार अक्षर-समूहों में से तीन किसी निश्चित तरीके से आपस में संगत हैं जबकि कोई एक उनसे असंगत है। असंगत अक्षर-समूह का चयन कीजिए।

- Ans 1. NPMR
 2. RTQV
 3. XZWB
 4. VXTZ

Question ID : 26433057240

Option 1 ID : 264330223946

Option 2 ID : 264330223945

Option 3 ID : 264330223944

Option 4 ID : 264330223947

Status : Answered

Chosen Option : 4

Q.35 दिए गए विकल्पों में से उस संख्या का चयन कीजिए जो निम्नलिखित श्रृंखला में प्रश्न चिह्न (?) के स्थान पर आ सकती है।
576, 288, 144, 72, ?

- Ans 1. 34
 2. 36
 3. 40
 4. 48

Question ID : 264330112669

Option 1 ID : 264330442764

Option 2 ID : 264330442763

Option 3 ID : 264330442762

Option 4 ID : 264330442761

Status : Answered

Chosen Option : 2

Q.36 यदि * () का अर्थ 'bread butter cake', '& ! *' का अर्थ 'cake and cutter' है, ') (!' का अर्थ 'bread and butter' है, तो * * * * का अर्थ _____ होगा।

- Ans
- 1. Butter Butter Butter
 - 2. Bread Bread Bread
 - 3. Cake Cake Cake
 - 4. Cutter Cutter Cutter

Question ID : 26433081993

Option 1 ID : 264330321806

Option 2 ID : 264330321808

Option 3 ID : 264330321805

Option 4 ID : 264330321807

Status : Answered

Chosen Option : 3

ixamBee

Prepare 50% Faster

Q.37 उस विकल्प का चयन करें जिसमें दी गई आकृति अंतर्निहित है (घुमाने की अनुमति नहीं है)।

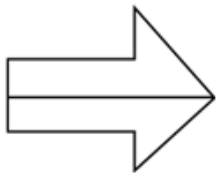

Ans

✗ 1.

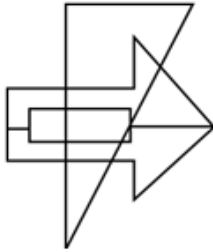

✓ 2.

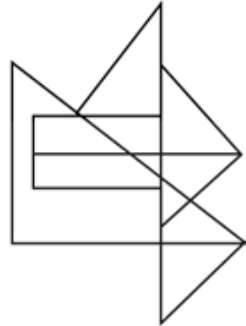

✗ 3.

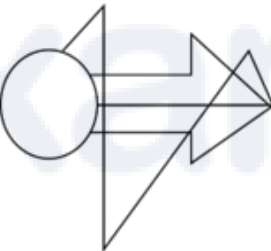

✗ 4.

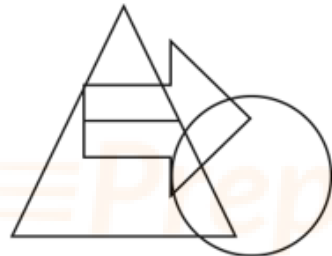

Question ID : 264330132510

Option 1 ID : 264330519138

Option 2 ID : 264330519136

Option 3 ID : 264330519137

Option 4 ID : 264330519135

Status : Answered

Chosen Option : 2

Q.38 निम्नांकित श्रृंखला में पैटर्न को जारी रखने के लिए प्रश्नचिह्न (?) को किस आकृति द्वारा प्रतिस्थापित किया जाना चाहिए?

3	C	<input type="checkbox"/>	3	S	<input type="checkbox"/>	O	S									
D	O	L	X	O	D	X	L	D	X	L	3	X	D	3	L	?
<input type="checkbox"/>	6	6	C	O	6	6	<input type="checkbox"/>									

Ans

✗ 1.

6	<input type="checkbox"/>
O	3
D	S
X	L

✗ 2.

☆	O
L	X
D	3
<input type="checkbox"/>	S

✓ 3.

☆	O
D	3
L	S
X	6

✗ 4.

<input type="checkbox"/>	O
D	3
L	S
X	6

Question ID : 264330129594

Option 1 ID : 264330507743

Option 2 ID : 264330507744

Option 3 ID : 264330507745

Option 4 ID : 264330507742

Status : Answered

Chosen Option : 2

Q.39 उस समुच्चय का चयन कीजिए, जिसमें संख्याएँ उसी तरह से संबंधित हैं, जिस प्रकार दिए गए समुच्चय की संख्याएँ आपस में संबंधित हैं। (नोट: संख्याओं को उसके घटक अंकों में विभाजित किए बिना, पूर्ण संख्याओं पर ही गणितीय संक्रियाएँ की जानी चाहिए। जैसे 13 - मान लीजिए 13 पर गणितीय संक्रियाएँ जैसे कि 13 में जोड़ना/घटाना/गुणा करना आदि किया जा सकता है। 13 को 1 और 3 में तोड़कर और फिर 1 और 3 पर गणितीय संक्रियाएँ करने की अनुमति नहीं है।)
(18, 39, 60)
(12, 27, 42)

- Ans
- 1. (20, 37, 60)
 - 2. (16, 35, 54)
 - 3. (8, 19, 33)
 - 4. (11, 25, 33)

Question ID : 26433078963

Option 1 ID : 264330309867

Option 2 ID : 264330309866

Option 3 ID : 264330309864

Option 4 ID : 264330309865

Status : Answered

Chosen Option : 2

Q.40 उस विकल्प का चयन करें जिसमें दी गई आकृति अंतर्निहित है (घुमाने की अनुमति नहीं है)।

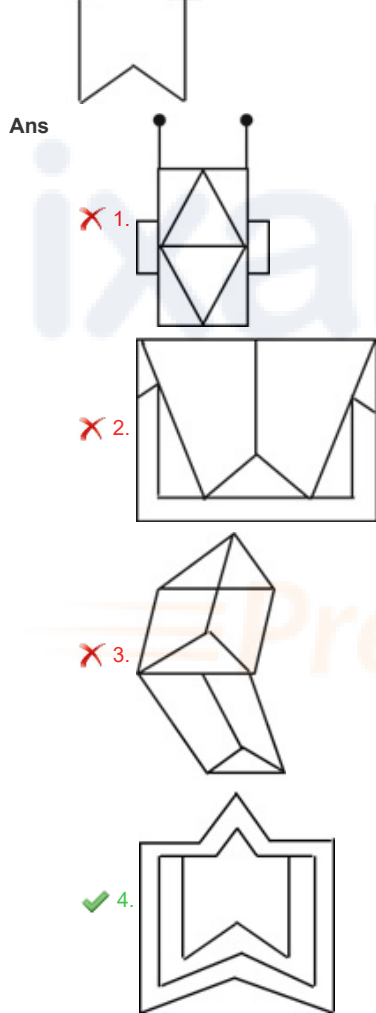

Question ID : 264330111650

Option 1 ID : 264330438688

Option 2 ID : 264330438685

Option 3 ID : 264330438687

Option 4 ID : 264330438686

Status : Answered

Chosen Option : 4

Q.41 यदि "he loves coffee" को 123 के रूप में कूटबद्ध किया जाता है, "coffee has caffeine" को 245 के रूप में कूटबद्ध किया जाता है, "he coffee caffeine" को 125 और "caffeine is bad" को 567 के रूप में कूटबद्ध किया जाता है, तो "he" को _____ के द्वारा दर्शाया जाएगा।

- Ans
- 1. 4
 - 2. 3
 - 3. 2
 - 4. 1

Question ID : 26433081990
 Option 1 ID : 264330321796
 Option 2 ID : 264330321795
 Option 3 ID : 264330321794
 Option 4 ID : 264330321793
 Status : Answered
 Chosen Option : 4

Q.42 निम्नलिखित चार अक्षर-समूहों में से तीन एक निश्चित तरीके से आपस में संगत है, जबकि कोई एक उनसे असंगत है। असंगत अक्षर-समूह का चयन करें।

- Ans
- 1. ZNS
 - 2. WKO
 - 3. XLQ
 - 4. QEJ

Question ID : 26433058001
 Option 1 ID : 264330226991
 Option 2 ID : 264330226989
 Option 3 ID : 264330226990
 Option 4 ID : 264330226988
 Status : Answered
 Chosen Option : 2

Q.43 दी गई श्रृंखला को पूरा करने के लिए कौन-सा अक्षर-समूह प्रश्नवाचक चिह्न (?) को प्रतिस्थापित करेगा?

VRPL, UQOK, ? , SOMI, RNLH

- Ans
- 1. TOMJ
 - 2. TPMK
 - 3. TOJN
 - 4. TPNJ

Question ID : 264330144908
 Option 1 ID : 264330567887
 Option 2 ID : 264330567888
 Option 3 ID : 264330567890
 Option 4 ID : 264330567889
 Status : Answered
 Chosen Option : 4

Q.44 यदि 'A' का अर्थ '+' है, 'B' का अर्थ '×' है, 'C' का अर्थ '+' है और 'D' का अर्थ '-' है, तो निम्नलिखित समीकरण में प्रश्न चिह्न (?) के स्थान पर क्या आएगा?
13 B 3 D 15 A 3 C 6 = ?

- Ans 1. 30
 2. 35
 3. 45
 4. 40

Question ID : 264330141901
 Option 1 ID : 264330555923
 Option 2 ID : 264330555924
 Option 3 ID : 264330555926
 Option 4 ID : 264330555925
 Status : Answered
 Chosen Option : 4

Q.45 उस विकल्प का चयन करें, जो छठी संख्या से उसी प्रकार संबंधित है, जिस प्रकार पहली संख्या दूसरी संख्या से और तीसरी संख्या चौथी संख्या से संबंधित है।
147 : 3 :: 343 : 7 :: ? : 9

- Ans 1. 426
 2. 388
 3. 432
 4. 441

Question ID : 26433087208
 Option 1 ID : 264330342472
 Option 2 ID : 264330342469
 Option 3 ID : 264330342470
 Option 4 ID : 264330342471
 Status : Answered
 Chosen Option : 4

Q.46 दी गई आकृति में कितने त्रिभुज हैं?

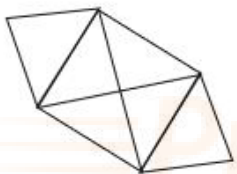

- Ans 1. 9
 2. 12
 3. 8
 4. 10

Question ID : 26433068623
 Option 1 ID : 264330269005
 Option 2 ID : 264330269006
 Option 3 ID : 264330269007
 Option 4 ID : 264330269004
 Status : Answered
 Chosen Option : 4

Q.47 यदि 'A' का अर्थ '+' है, 'B' का अर्थ 'x' है, 'C' का अर्थ '+' है और 'D' का अर्थ '-' है, तो निम्नलिखित समीकरण में प्रश्न चिह्न (?) के स्थान पर क्या आएगा?
9 B 14 D 16 C 40 A 10 = ?

- Ans 1. 112
 2. 114
 3. 116
 4. 118

Question ID : 264330141908
Option 1 ID : 264330555951
Option 2 ID : 264330555952
Option 3 ID : 264330555953
Option 4 ID : 264330555954
Status : Answered
Chosen Option : 2

Q.48 उस विकल्प का चयन करें जो तीसरे शब्द से उसी प्रकार संबंधित है जिस प्रकार दूसरा शब्द पहले शब्द से संबंधित है। (शब्दों को अर्थपूर्ण हिन्दी शब्दों के रूप में माना जाना चाहिए और इन्हें शब्द में अक्षरों की संख्या/व्यंजनों की संख्या/स्वरों की संख्या के आधार पर एक-दूसरे से संबद्ध नहीं किया जाना चाहिए।)
सवार (Riders) : सवार-दल (Cavalcade) :: दीमक (Termites) : ?

- Ans 1. बैंड (Band)
 2. देश (Country)
 3. कॉलोनी (Colony)
 4. लोग (People)

Question ID : 26433069581
Option 1 ID : 264330272838
Option 2 ID : 264330272837
Option 3 ID : 264330272839
Option 4 ID : 264330272836
Status : Answered
Chosen Option : 1

Q.49 नितिन अपने घर से निकलता है और 45 m पूर्व की ओर चलता है। फिर वह बाएँ मुड़ता है और 48 m चलता है। वह फिर से बाएँ मुड़ता है और 27 m चलता है। वह अंतिम बार बाएँ मुड़ता है और 55 m चलता है। वह उस खंभे से कितनी दूर है, जो उसके घर से ठीक 7 m दक्षिण में है?
(मान लें कि सभी मोड़ केवल 90° वाले मोड़ हैं।)

- Ans 1. 16 m
 2. 28 m
 3. 18 m
 4. 31 m

Question ID : 264330131623
Option 1 ID : 264330515592
Option 2 ID : 264330515593
Option 3 ID : 264330515594
Option 4 ID : 264330515591
Status : Answered
Chosen Option : 3

Q.50 'A + B' का अर्थ है 'A, B का बेटा है'
'A - B' का अर्थ है 'A, B की पत्नी है'
'A × B' का अर्थ है 'A, B का पिता है'
'A ÷ B' का अर्थ है 'A, B का भाई है'
यदि 'C + M - S × K - P ÷ T' है, तो निम्नलिखित में से कौन-सा कथन सही नहीं है?

- Ans
- 1. K, M की पुत्री है।
 - 2. C, S का बेटा है।
 - 3. K, M की भतीजी है।
 - 4. K, T के भाई की पत्नी है।

Question ID : 264330102486
Option 1 ID : 264330402374
Option 2 ID : 264330402375
Option 3 ID : 264330402376
Option 4 ID : 264330402373
Status : Answered
Chosen Option : 3

Section : General Awareness

Q.1 भारत में रेडियो प्रसारण, बॉम्बे (मुंबई) के रेडियो क्लब द्वारा _____ में शुरू किया गया था।

- Ans
- 1. 1934
 - 2. 1938
 - 3. 1929
 - 4. 1923

Question ID : 264330163225
Option 1 ID : 264330640213
Option 2 ID : 264330640214
Option 3 ID : 264330640212
Option 4 ID : 264330640211
Status : Not Answered
Chosen Option : --

Q.2 निम्नलिखित में से किस समादेश के द्वारा सर्वोच्च न्यायालय और उच्च न्यायालय, अधिकार क्षेत्र से बाहर दिए गए किसी फैसले के संबंध में अवर कोर्ट से कार्यवाही के रिकॉर्ड पुनरीक्षण के लिए मांग सकते हैं?

- Ans
- 1. निषेध
 - 2. परमादेश
 - 3. उत्प्रेषण
 - 4. बन्दी प्रत्यक्षीकरण

Question ID : 264330112773
Option 1 ID : 264330443179
Option 2 ID : 264330443178
Option 3 ID : 264330443180
Option 4 ID : 264330443177
Status : Answered
Chosen Option : 2

Q.3 मोहिनीअट्टम निम्नलिखित में से किस राज्य में लोकप्रिय एक प्रसिद्ध नृत्य शैली है?

- Ans
- 1. गुजरात
 - 2. उत्तर प्रदेश
 - 3. पंजाब
 - 4. केरल

Question ID : 264330109270
 Option 1 ID : 264330429357
 Option 2 ID : 264330429358
 Option 3 ID : 264330429360
 Option 4 ID : 264330429359
 Status : Answered
 Chosen Option : 4

Q.4 सोनल मानसिंह _____ की एक प्रमुख नर्तकी हैं।

- Ans
- 1. सत्रीया
 - 2. भरतनाट्यम
 - 3. मणिपुरी नृत्य
 - 4. कथक

Question ID : 264330164798
 Option 1 ID : 264330646319
 Option 2 ID : 264330646320
 Option 3 ID : 264330646322
 Option 4 ID : 264330646321
 Status : Answered
 Chosen Option : 1

Q.5 भारत के योजना आयोग (2011-12) के अनुसार, राज्यों के किस समूह में गरीबी रेखा के नीचे की जनसंख्या का प्रतिशत सबसे कम है?

- Ans
- 1. गुजरात और हरियाणा
 - 2. छत्तीसगढ़ और झारखंड
 - 3. केरल और हिमाचल प्रदेश
 - 4. बिहार और ओडिशा

Question ID : 264330119923
 Option 1 ID : 264330469969
 Option 2 ID : 264330469968
 Option 3 ID : 264330469970
 Option 4 ID : 264330469967
 Status : Answered
 Chosen Option : 1

Q.6 निम्नलिखित में से कौन-सा विकल्प संघ सीलेंटरेटा से संबंधित है?

- Ans
- 1. स्पंजिला (Spongilla)
 - 2. यूस्पंजिया (Euspongia)
 - 3. ऑरिलिया (Aurelia)
 - 4. साइकॉन (Sycon)

Question ID : 264330131676
 Option 1 ID : 264330515806
 Option 2 ID : 264330515805
 Option 3 ID : 264330515803
 Option 4 ID : 264330515804
 Status : Not Answered
 Chosen Option : --

Q.7 जनसंख्या घनत्व के घटक के संबंध में निम्नलिखित में से कौन-सा एक राज्य असंगत है?

- Ans
- 1. बिहार
 - 2. अरुणाचल प्रदेश
 - 3. तमिलनाडु
 - 4. उत्तर प्रदेश

Question ID : 264330166812
 Option 1 ID : 264330654284
 Option 2 ID : 264330654283
 Option 3 ID : 264330654285
 Option 4 ID : 264330654286
 Status : Answered
 Chosen Option : 2

Q.8 'जल्लीकट्टू' खेल का संबंध निम्नलिखित में से किस राज्य से है?

- Ans
- 1. केरल
 - 2. तमिलनाडु
 - 3. दिल्ली
 - 4. ओडिशा

Question ID : 264330110331
 Option 1 ID : 264330433601
 Option 2 ID : 264330433604
 Option 3 ID : 264330433603
 Option 4 ID : 264330433602
 Status : Answered
 Chosen Option : 2

Q.9 पंडित भीमसेन जोशी हिंदुस्तानी शास्त्रीय संगीत के किस रूप के प्रतिपादक थे?

- Ans
- 1. ध्रुपद
 - 2. टप्पा
 - 3. ठुमरी
 - 4. खयाल

Question ID : 26433064245
 Option 1 ID : 264330251572
 Option 2 ID : 264330251575
 Option 3 ID : 264330251574
 Option 4 ID : 264330251573
 Status : Not Answered
 Chosen Option : --

Q.10 विद्युत जनरेटर और विद्युत मोटर किस सिद्धांत पर कार्य करते हैं?

- Ans
- 1. फ्लेमिंग के दाएं हाथ के नियम
 - 2. क्रमशः फ्लेमिंग के दाएं हाथ के नियम और बाएं हाथ के नियम
 - 3. फ्लेमिंग के बाएं हाथ के नियम
 - 4. क्रमशः फ्लेमिंग के बाएं हाथ के नियम और दाएं हाथ के नियम

Question ID : 264330169283
 Option 1 ID : 264330663912
 Option 2 ID : 264330663914
 Option 3 ID : 264330663911
 Option 4 ID : 264330663913
 Status : Answered
 Chosen Option : 3

Q.11 निम्नलिखित में से कौन-सी भारत में एकमात्र ऊर्ध्वाधर रूप से एकीकृत प्रमुख तांबा उत्पादक कंपनी है?

- Ans
- 1. हिंडालको इंडस्ट्री (खिड़ला कॉपर)
 - 2. स्टरलाइट इंडस्ट्री ज
 - 3. हिंदुस्तान कॉपर लिमिटेड
 - 4. झगड़िया कॉपर लिमिटेड

Question ID : 26433064530
 Option 1 ID : 264330252714
 Option 2 ID : 264330252713
 Option 3 ID : 264330252712
 Option 4 ID : 264330252715
 Status : Answered
 Chosen Option : 3

Q.12 'भौतिक भूविज्ञान (physical geology)' पद का प्रतिपादन किसके द्वारा किया गया?

- Ans
- 1. जॉर्जियस एग्रीकोला
 - 2. लुइस अगासिज़
 - 3. विलियम हॉपकिंस
 - 4. अज़ीज़ अबसबेर

Question ID : 264330117626
 Option 1 ID : 264330462530
 Option 2 ID : 264330462532
 Option 3 ID : 264330462529
 Option 4 ID : 264330462531
 Status : Not Answered
 Chosen Option : --

Q.13 त्रिशूलगंगा _____ नदी की एक धारा है।

- Ans
- 1. गोदावरी
 - 2. घाघरा
 - 3. गंडक
 - 4. ब्यास

Question ID : 264330166802
 Option 1 ID : 264330654244
 Option 2 ID : 264330654246
 Option 3 ID : 264330654245
 Option 4 ID : 264330654243
 Status : Answered
 Chosen Option : 1

Q.14 निम्नलिखित में से किस शहर में भारत की पहली अंडरवाटर ट्रेन परियोजना शुरू की गई है?

- Ans
- 1. इलाहाबाद
 - 2. कोलकाता
 - 3. हरिद्वार
 - 4. पटना

Question ID : 264330166202
 Option 1 ID : 264330651878
 Option 2 ID : 264330651875
 Option 3 ID : 264330651877
 Option 4 ID : 264330651876
 Status : Not Answered
 Chosen Option : --

Q.15 मानस, रणथंभौर, कान्हा और सुंदरबन _____ हैं।

- Ans
- 1. जीन बैंक
 - 2. चिड़ियाघर
 - 3. पक्षी अभयारण्य
 - 4. राष्ट्रीय उद्यान

Question ID : 264330170001
 Option 1 ID : 264330666682
 Option 2 ID : 264330666679
 Option 3 ID : 264330666681
 Option 4 ID : 264330666680
 Status : Answered
 Chosen Option : 4

Q.16 गोदावरी नदी का अपवाह बेसिन भारत के निम्नलिखित में से किन राज्यों में फैला हुआ है?

- Ans
- 1. छत्तीसगढ़, महाराष्ट्र, कर्नाटक, तमिलनाडु और ओडिशा
 - 2. छत्तीसगढ़, आंध्र प्रदेश, केरल, कर्नाटक और तमिलनाडु
 - 3. छत्तीसगढ़, महाराष्ट्र, आंध्र प्रदेश, मध्य प्रदेश, कर्नाटक और ओडिशा
 - 4. महाराष्ट्र, आंध्र प्रदेश, केरल, कर्नाटक और तमिलनाडु

Question ID : 264330111922
 Option 1 ID : 264330439774
 Option 2 ID : 264330439775
 Option 3 ID : 264330439773
 Option 4 ID : 264330439776
 Status : Not Answered
 Chosen Option : --

Q.17 भगोरिया स्वांग निम्नलिखित में से किस त्योहार से संबंधित है?

- Ans
- 1. दशहरा
 - 2. दिवाली
 - 3. शिवरात्रि
 - 4. होली

Question ID : 26433074089
 Option 1 ID : 264330290478
 Option 2 ID : 264330290476
 Option 3 ID : 264330290477
 Option 4 ID : 264330290479
 Status : Answered
 Chosen Option : 4

Q.18 किस टीम ने UEFA यूरो कप 2020 फुटबॉल खिताब जीता?

- Ans
- 1. इंग्लैंड
 - 2. फ्रांस
 - 3. जर्मनी
 - 4. इटली

Question ID : 264330110330
 Option 1 ID : 264330433597
 Option 2 ID : 264330433598
 Option 3 ID : 264330433600
 Option 4 ID : 264330433599
 Status : Not Answered
 Chosen Option : --

Q.19 भारत वन स्थिति रिपोर्ट 2021 के अनुसार, _____ समूह कुल भौगोलिक क्षेत्र के 4,992 km² को कवर करता है।

- Ans
- 1. पर्वतीय
 - 2. अल्पाइन
 - 3. मैग्रोव
 - 4. कंटक

Question ID : 264330113476
Option 1 ID : 264330445990
Option 2 ID : 264330445991
Option 3 ID : 264330445992
Option 4 ID : 264330445989
Status : Not Answered
Chosen Option : --

Q.20 वृद्ध व्यक्तियों को मोतियाबिंद हो जाने पर क्या हो जाता है?

- Ans
- 1. पुतली सुस्त हो जाती है
 - 2. वृद्धावस्था में व्यक्तियों का क्रिस्टलीय लेंस स्पष्ट और चमकदार हो जाता है
 - 3. परितारिका धुंधली हो जाती है
 - 4. वृद्धावस्था में व्यक्तियों का क्रिस्टलीय लेंस दूधिया और धुंधला हो जाता है

Question ID : 264330134849
Option 1 ID : 264330528331
Option 2 ID : 264330528334
Option 3 ID : 264330528332
Option 4 ID : 264330528333
Status : Answered
Chosen Option : 4

Q.21 निम्नलिखित में से किसे 'बांग्लादेश का जनक' कहा जाता है?

- Ans
- 1. शेख हसीना
 - 2. अताउर रहमान खान
 - 3. मोहम्मद हबीबुर्रहमान
 - 4. शेख मुजीबुर्रहमान

Question ID : 264330119832
Option 1 ID : 264330469605
Option 2 ID : 264330469603
Option 3 ID : 264330469604
Option 4 ID : 264330469606
Status : Answered
Chosen Option : 3

Q.22 श्रीनिवास वर्धन को किस क्षेत्र में असाधारण और विशिष्ट सेवा के लिए वर्ष 2023 के पद्म विभूषण से सम्मानित किया गया?

- Ans
- 1. सार्वजनिक मामले
 - 2. वास्तुकला
 - 3. विज्ञान और अभियांत्रिकी
 - 4. कला

Question ID : 264330133008
Option 1 ID : 264330521090
Option 2 ID : 264330521087
Option 3 ID : 264330521089
Option 4 ID : 264330521088
Status : Answered
Chosen Option : 4

Q.23 निम्नलिखित में से किस पंचवर्षीय योजना की शुरुआत से पहले भारत ने संरचनात्मक समायोजन नीतियों की शुरुआत की थी?

- Ans
- 1. छठी पंचवर्षीय योजना
 - 2. नौवीं पंचवर्षीय योजना
 - 3. आठवीं पंचवर्षीय योजना
 - 4. सातवीं पंचवर्षीय योजना

Question ID : 264330111732
Option 1 ID : 264330439013
Option 2 ID : 264330439016
Option 3 ID : 264330439015
Option 4 ID : 264330439014
Status : Not Answered
Chosen Option : --

Q.24 'लेट बॉल', 'स्ट्रो बॉल' और 'नो लेट' किस खेल का हिस्सा हैं?

- Ans
- 1. स्कैश
 - 2. रग्बी
 - 3. हैंडबॉल
 - 4. पोलो

Question ID : 264330119290
Option 1 ID : 264330467448
Option 2 ID : 264330467450
Option 3 ID : 264330467449
Option 4 ID : 264330467447
Status : Not Answered
Chosen Option : --

Q.25 कम आय वाले परिवारों को गैर-सूक्ष्म वित्त ऋण प्रदान करने के लिए, मासिक घरेलू आय के प्रतिशत के रूप में, परिवार के मासिक ऋण पुनर्भुगतान दायित्वों पर _____ की सीमा होती है।

- Ans
- 1. 25%
 - 2. 50%
 - 3. 40%
 - 4. 75%

Question ID : 264330109087
Option 1 ID : 264330428626
Option 2 ID : 264330428625
Option 3 ID : 264330428627
Option 4 ID : 264330428628
Status : Not Answered
Chosen Option : --

Q.26 निम्नलिखित में से कौन-सा खाद्य में प्रत्यक्ष जैविक खतरे को दर्शाता है?

- Ans
- 1. वायरस
 - 2. प्रोटोजोआ
 - 3. यीस्ट
 - 4. कैटरपिलर

Question ID : 264330131706

Option 1 ID : 264330515926

Option 2 ID : 264330515923

Option 3 ID : 264330515925

Option 4 ID : 264330515924

Status : Answered

Chosen Option : 1

Q.27 सदन की बैठक का पहला घंटा, जो प्रश्न पूछने और उत्तर देने के लिए आवंटित किया जाता है, कहलाता है।

- Ans
- 1. शून्यकाल
 - 2. परिनिदा प्रस्ताव
 - 3. विशेषाधिकार प्रस्ताव
 - 4. प्रश्नकाल

Question ID : 264330130787

Option 1 ID : 264330512262

Option 2 ID : 264330512260

Option 3 ID : 264330512259

Option 4 ID : 264330512261

Status : Answered

Chosen Option : 4

Q.28 निम्नलिखित में से कौन-सा यूकेरियोटिक, बहुकोशिकीय और स्वपोषी जीव है?

- Ans
- 1. जीवाणु
 - 2. कुकुरमुत्ता
 - 3. जानवर
 - 4. पादप

Question ID : 264330111880

Option 1 ID : 264330439605

Option 2 ID : 264330439608

Option 3 ID : 264330439607

Option 4 ID : 264330439606

Status : Not Answered

Chosen Option : --

Q.29 हड़प्पा सभ्यता के नगरों के बारे में दिए गए कथनों के आधार पर सही विकल्प का चयन कीजिए।

कथन I: हड़प्पा के अधिकांश नगर दो भागों में विभाजित थे: ऊपरी नगर और निचला नगर।
कथन II: पुरातत्वविद्, नगरों के निचले हिस्से को गढ़ (Citadel) के रूप में वर्णित करते हैं।

- Ans
- ✓ 1. केवल कथन I सत्य है।
 - ✗ 2. केवल कथन II सत्य है।
 - ✗ 3. कथन I और कथन II दोनों सत्य हैं।
 - ✗ 4. न तो कथन I सत्य है और न ही कथन II सत्य है।

Question ID : 264330141808
Option 1 ID : 264330555551
Option 2 ID : 264330555552
Option 3 ID : 264330555553
Option 4 ID : 264330555554
Status : Answered
Chosen Option : 3

Q.30 मार्च 2023 में, केंद्रीय सामाजिक न्याय और अधिकारिता मंत्रालय ने किस संगठन के साथ एक समझौता किया, जिसके अनुसार आगे आने वाले नेता और समर्थक नशा मुक्त भारत अभियान (एनएमबीए) नामक इस प्रमुख केंद्रीय कार्यक्रम को आगे बढ़ाएंगे?

- Ans
- ✗ 1. श्री तुलसी पीठ सेवा न्यास, चित्रकूट
 - ✗ 2. पतंजलि योगपीठ, हरिद्वार
 - ✗ 3. आर्ट ऑफ लिविंग, बेंगलुरु
 - ✓ 4. प्रजापिता ब्रह्माकुमारी ईश्वरीय विश्व विद्यालय, माउंट आबू

Question ID : 264330158470
Option 1 ID : 264330621241
Option 2 ID : 264330621239
Option 3 ID : 264330621240
Option 4 ID : 264330621242
Status : Not Answered
Chosen Option : --

Q.31 गुरु केलुचरण महापात्र वार्षिक पुरस्कार किस राज्य के द्वारा प्रदान किया जाता है?

- Ans
- ✓ 1. ओडिशा
 - ✗ 2. मणिपुर
 - ✗ 3. तमिलनाडु
 - ✗ 4. कर्नाटक

Question ID : 264330157017
Option 1 ID : 264330615444
Option 2 ID : 264330615443
Option 3 ID : 264330615446
Option 4 ID : 264330615445
Status : Answered
Chosen Option : 1

Q.32 मार्च 2023 तक प्राप्त जानकारी के अनुसार, केंद्रीय कॉर्पोरेट कार्य मंत्री कौन हैं?

- Ans
- 1. स्मृति ईरानी
 - 2. पीयूष गोयल
 - 3. अश्विनी वैष्णव
 - 4. निर्मला सीतारमण

Question ID : 264330165221
Option 1 ID : 264330647986
Option 2 ID : 264330647985
Option 3 ID : 264330647983
Option 4 ID : 264330647984
Status : Answered
Chosen Option : 2

Q.33 असिक्नी, जो सप्त-सिंधु का एक भाग थी, वर्तमान समय में निम्नलिखित में से किस नदी का नाम है?

- Ans
- 1. झेलम
 - 2. चिनाब
 - 3. रावी
 - 4. व्यास

Question ID : 264330165336
Option 1 ID : 264330648423
Option 2 ID : 264330648424
Option 3 ID : 264330648425
Option 4 ID : 264330648426
Status : Not Answered
Chosen Option : --

Q.34 दौल उत्सव मुख्यतः निम्नलिखित में से किस राज्य में मनाया जाता है?

- Ans
- 1. छत्तीसगढ़
 - 2. महाराष्ट्र
 - 3. असम
 - 4. बिहार

Question ID : 264330117935
Option 1 ID : 264330463556
Option 2 ID : 264330463555
Option 3 ID : 264330463558
Option 4 ID : 264330463557
Status : Answered
Chosen Option : 1

Q.35 इनमें से कौन 'मैला आँचल' नामक उपन्यास के रचयिता हैं?

- Ans
- 1. कमलेश्वर
 - 2. फणीश्वर नाथ 'रेणु'
 - 3. काशीनाथ सिंह
 - 4. हरिशंकर परसाई

Question ID : 264330144838
Option 1 ID : 264330567607
Option 2 ID : 264330567608
Option 3 ID : 264330567610
Option 4 ID : 264330567609
Status : Not Answered
Chosen Option : --

Q.36 निम्नलिखित में से कौन-सा उपन्यास आर. के. नारायण द्वारा लिखा गया है और इसी नाम से एक हिंदी फिल्म में रूपांतरित भी किया गया है?

- Ans
- 1. श्री इंडियन्स
 - 2. द गाइड
 - 3. देवदास
 - 4. हैलो

Question ID : 26433071710
Option 1 ID : 264330281266
Option 2 ID : 264330281264
Option 3 ID : 264330281265
Option 4 ID : 264330281267
Status : Answered
Chosen Option : 1

Q.37 अधिकांश तारककेन्द्रों में ट्रिपल सूक्ष्मनलिकाओं की एक _____ संरचना होती है, जो युग्म में मौजूद होती है और दोहराव के बाद लंबकोणतः व्यवस्थित होती है।

- Ans
- 1. 9 + 0
 - 2. 8 + 0
 - 3. 9 + 3
 - 4. 6 + 1

Question ID : 264330113474
Option 1 ID : 264330445984
Option 2 ID : 264330445982
Option 3 ID : 264330445981
Option 4 ID : 264330445983
Status : Not Answered
Chosen Option : --

Q.38 टेबल टेनिस में, जिस अवधि के दौरान गेंद खेल में होती है उसे क्या कहा जाता है?

- Ans
- 1. लेट
 - 2. रैली
 - 3. ऑब्स्ट्रक्शन
 - 4. प्वाइंट

Question ID : 264330110384
Option 1 ID : 264330433815
Option 2 ID : 264330433813
Option 3 ID : 264330433816
Option 4 ID : 264330433814
Status : Answered
Chosen Option : 2

Q.39 चेम्बेटी श्रीधरालु नायडू एक समाज सुधारक थे। वे निम्नलिखित में से किस संगठन से संबंधित थे?

- Ans
- 1. आर्य समाज
 - 2. ब्रह्म समाज
 - 3. परमहंस मंडली
 - 4. वेद समाज

Question ID : 264330165401
Option 1 ID : 264330648684
Option 2 ID : 264330648685
Option 3 ID : 264330648683
Option 4 ID : 264330648686
Status : Answered
Chosen Option : 3

Q.40 निम्नलिखित में से उस प्रक्रिया की पहचान कीजिए जिसमें रासायनिक अभिक्रिया शामिल नहीं है।

- Ans
- 1. साबुन के कारण हल्दी का रंग बदलना
 - 2. डिटरजेंट का उपयोग करके कपड़े साफ करना
 - 3. नेल पॉलिश रिमूवर का शीतलन प्रभाव
 - 4. आम का पकना

Question ID : 264330169291
Option 1 ID : 264330663946
Option 2 ID : 264330663945
Option 3 ID : 264330663944
Option 4 ID : 264330663943
Status : Answered
Chosen Option : 4

Q.41 निम्नलिखित में से कौन-सा राजवंश बंगाल के पाल वंश का उत्तराधिकारी बना?

- Ans
- 1. मौखरि
 - 2. देवास
 - 3. गौड़
 - 4. सेन

Question ID : 264330106598
Option 1 ID : 264330418693
Option 2 ID : 264330418695
Option 3 ID : 264330418694
Option 4 ID : 264330418696
Status : Not Answered
Chosen Option : --

Q.42 प्रथम और द्वितीय विश्व युद्ध के कारण किन वर्षों में ओलंपिक खेल आयोजित नहीं किए गए थे?

- Ans
- 1. 1920, 1944, 1948
 - 2. 1916, 1940, 1944
 - 3. 1916, 1936, 1940
 - 4. 1924, 1940, 1944

Question ID : 264330110362
Option 1 ID : 264330433727
Option 2 ID : 264330433725
Option 3 ID : 264330433726
Option 4 ID : 264330433728
Status : Not Answered
Chosen Option : --

Q.43 खयाल के प्रतिपादक के रूप में, पंडित भीमसेन जोशी किस संगीत घराने से संबंधित थे?

- Ans
- 1. ग्वालियर
 - 2. बनारस
 - 3. किराना
 - 4. आगरा

Question ID : 26433064247
Option 1 ID : 264330251580
Option 2 ID : 264330251582
Option 3 ID : 264330251583
Option 4 ID : 264330251581
Status : Not Answered
Chosen Option : --

Q.44 ब्रिटिश औपनिवेशिक सरकार द्वारा भरतनाट्यम पर प्रतिबंध कब लगाया गया था?

- Ans
- 1. 1885 में
 - 2. 1927 में
 - 3. 1910 में
 - 4. 1897 में

Question ID : 264330109271
Option 1 ID : 264330429363
Option 2 ID : 264330429362
Option 3 ID : 264330429364
Option 4 ID : 264330429361
Status : Not Answered
Chosen Option : --

Q.45 सिंधु घाटी सभ्यता के निम्नलिखित में से किस स्थल पर विशाल स्नानागार की खोज की गई थी?

- Ans
- 1. कालीबंगा
 - 2. लोथल
 - 3. धौलावीरा
 - 4. मोहन जोदड़ो

Question ID : 264330144835
Option 1 ID : 264330567596
Option 2 ID : 264330567598
Option 3 ID : 264330567597
Option 4 ID : 264330567595
Status : Answered
Chosen Option : 4

Q.46 निम्नलिखित अक्षरों की गणना के लिए निम्नलिखित में से कौन सा सही सूत्र है?

- Ans
- 1. अक्षरों की गणना - सिसिडी
 - 2. अक्षरों की गणना - सिसिडी
 - 3. अक्षरों की गणना + सिसिडी
 - 4. अक्षरों की गणना + सिसिडी

Question ID : 264330109375
Option 1 ID : 264330429778
Option 2 ID : 264330429780
Option 3 ID : 264330429777
Option 4 ID : 264330429779
Status : Answered
Chosen Option : 1

Q.47 पंजाब के किस राजा ने शाहशुजा और अंग्रेजी कंपनी के साथ त्रिपक्षीय संधि की थी?

- Ans
- 1. लाल सिंह
 - 2. दिलीप सिंह
 - 3. रणजीत सिंह
 - 4. खड़क सिंह

Question ID : 264330112189
Option 1 ID : 264330440842
Option 2 ID : 264330440844
Option 3 ID : 264330440841
Option 4 ID : 264330440843
Status : Not Answered
Chosen Option : --

Q.48 सियालकोट किसकी राजधानी थी?

- Ans
- 1. डिमेट्रियस (Demetrios)
 - 2. यूक्रेटाइडस (Eukratides)
 - 3. पुष्यमित्र (Pushyamitra)
 - 4. मिलिंद (Menander)

Question ID : 264330112146

Option 1 ID : 264330440669

Option 2 ID : 264330440672

Option 3 ID : 264330440671

Option 4 ID : 264330440670

Status : Not Answered

Chosen Option : --

Q.49 भारत सरकार के पर्यटन मंत्रालय द्वारा 2014-15 में शुरू की गई स्वदेश दर्शन योजना (एसडीएस) को 2023 में _____ के नए रूप में पेश किया गया है।

- Ans
- 1. स्वदेश दर्शन 2.0 (एसडी 2.0)
 - 2. स्वदेश दर्शन 4.0 (एसडी 4.0)
 - 3. स्वदेश दर्शन 3.0 (एसडी 3.0)
 - 4. स्वदेश दर्शन 1.0 (एसडी1.0)

Question ID : 264330158460

Option 1 ID : 264330621200

Option 2 ID : 264330621202

Option 3 ID : 264330621201

Option 4 ID : 264330621199

Status : Not Answered

Chosen Option : --

Q.50 भारतीय राष्ट्रीय कांग्रेस ने _____ को औपनिवेशिक भारत में पहला स्वतंत्रता दिवस मनाया था।

- Ans
- 1. 29 दिसंबर 1929
 - 2. 26 जनवरी 1930
 - 3. 15 अगस्त 1930
 - 4. 2 अक्टूबर 1929

Question ID : 264330111400

Option 1 ID : 264330437685

Option 2 ID : 264330437688

Option 3 ID : 264330437686

Option 4 ID : 264330437687

Status : Answered

Chosen Option : 3

Q.1 Select the most appropriate option that can substitute the underlined segment in the given sentence. If there is no need to substitute it, select 'No substitution'.
Swetha seldom waters the plants, isn't it?

- Ans
- 1. No substitution
 - 2. does she
 - 3. is she
 - 4. doesn't it

Question ID : 264330132983
Option 1 ID : 264330520994
Option 2 ID : 264330520992
Option 3 ID : 264330520993
Option 4 ID : 264330520991
Status : Answered
Chosen Option : 2

Q.2 Select the most appropriate synonym of the underlined word in the following sentence.
She wore a whimsical dress adorned with colourful patterns.

- Ans
- 1. Sensible
 - 2. Tragic
 - 3. Fashionable
 - 4. Weird

Question ID : 264330168123
Option 1 ID : 264330659373
Option 2 ID : 264330659372
Option 3 ID : 264330659374
Option 4 ID : 264330659371
Status : Answered
Chosen Option : 3

Q.3 Select the most appropriate meaning of the given idiom.
In the blink of an eye

- Ans
- 1. Do something dangerous out of excitement
 - 2. Make someone confused
 - 3. In an extremely short time
 - 4. Become very confused

Question ID : 264330132894
Option 1 ID : 264330520637
Option 2 ID : 264330520636
Option 3 ID : 264330520638
Option 4 ID : 264330520635
Status : Answered
Chosen Option : 3

Q.4 The following sentence has been split into four segments. Identify the segment that contains a grammatical error.
The coach believed that / his team were not / playing to its potential / in the tournament.

- Ans**
- 1. The coach believed that
 - 2. in the tournament
 - 3. playing to its potential
 - 4. his team were not

Question ID : 264330139097
 Option 1 ID : 264330544995
 Option 2 ID : 264330544998
 Option 3 ID : 264330544997
 Option 4 ID : 264330544996
 Status : Answered
 Chosen Option : 3

Q.5 Sentences of a paragraph are given below. While the first and the last sentences (S1 and S6) are in the correct order, the sentences in between are jumbled up. Arrange the sentences in the correct order to form a meaningful and coherent paragraph.

- S1. We are living in the era of information and communication.
 A. Though information and knowledge are different, people with much information are considered knowledgeable.
 B. So, English language communication skills are indispensable for any job aspirant.
 C. To transfer information, the language widely used in today's world is English.
 D. Employers are not compromising with English communication skills of the employees.
 S6. What is strongly believed to be true is that English skills can be of great help when professionals are dealing with different nationalities.

- Ans**
- 1. BCDA
 - 2. CABD
 - 3. ADCB
 - 4. ACBD

Question ID : 26433063632
 Option 1 ID : 264330249146
 Option 2 ID : 264330249145
 Option 3 ID : 264330249147
 Option 4 ID : 264330249144
 Status : Answered
 Chosen Option : 4

Q.6 Select the most appropriate option that can substitute the underlined segment in the given sentence.

Extraordinary students are controlled thinkers and creators who learn best when their training is dynamic, approachable and project-based.

- Ans**
- 1. independent thinkers and creators
 - 2. liable thinker and creators
 - 3. biased thinkers and creator
 - 4. subjective thinkers and creator

Question ID : 26433096162
 Option 1 ID : 264330377418
 Option 2 ID : 264330377417
 Option 3 ID : 264330377419
 Option 4 ID : 264330377420
 Status : Answered
 Chosen Option : 1

Q.7 Select the most appropriate ANTONYM of the given word.
Jubilant

- Ans
- 1. Static
 - 2. Inflated
 - 3. Thrilled
 - 4. Despondent

Question ID : 264330168140
Option 1 ID : 264330659437
Option 2 ID : 264330659436
Option 3 ID : 264330659435
Option 4 ID : 264330659438
Status : Answered
Chosen Option : 3

Q.8 Select the most appropriate option to substitute the underlined segment in the given sentence.

The soldiers advanced when the bugle came.

- Ans
- 1. when the bugle died
 - 2. when the bugle blew
 - 3. when the bugle flew
 - 4. when the bugle ran

Question ID : 26433093476
Option 1 ID : 264330367132
Option 2 ID : 264330367130
Option 3 ID : 264330367131
Option 4 ID : 264330367129
Status : Answered
Chosen Option : 4

Q.9 Select the most appropriate ANTONYM of the underlined word in the following sentence.

The spirit of the room was very gloomy in his absence.

- Ans
- 1. Cheerful
 - 2. Lonely
 - 3. Grim
 - 4. Cloudy

Question ID : 264330164306
Option 1 ID : 264330644441
Option 2 ID : 264330644442
Option 3 ID : 264330644440
Option 4 ID : 264330644439
Status : Answered
Chosen Option : 1

Q.10 Select the option that expresses the following sentence in reported (or indirect) speech.

“Do you like your school?” asked the boy.

- Ans
- 1. The boy told me that he liked my school.
 - 2. The boy asked if he likes his school.
 - 3. The boy asked if he liked your school.
 - 4. The boy asked if I liked my school.

Question ID : 264330164345

Option 1 ID : 264330644594

Option 2 ID : 264330644592

Option 3 ID : 264330644591

Option 4 ID : 264330644593

Status : Answered

Chosen Option : 4

Q.11 Select the option that expresses the given sentence in passive voice.
The management promoted four employees.

- Ans
- 1. Four employees are promoted by the management.
 - 2. Four employees have been promoted by the management.
 - 3. Four employees were promoted by the management.
 - 4. Four employees have promoted by the management.

Question ID : 264330164360

Option 1 ID : 264330644652

Option 2 ID : 264330644654

Option 3 ID : 264330644651

Option 4 ID : 264330644653

Status : Answered

Chosen Option : 3

Q.12 Select the option that expresses the given sentence in passive voice.

Katrina repaired the cycle herself.

- Ans
- 1. Katrina herself was repairing the cycle.
 - 2. Katrina was repaired by the cycle herself.
 - 3. The cycle was repaired by Katrina herself.
 - 4. The cycle repaired Katrina herself.

Question ID : 264330164595

Option 1 ID : 264330645564

Option 2 ID : 264330645565

Option 3 ID : 264330645566

Option 4 ID : 264330645563

Status : Answered

Chosen Option : 3

Q.13 Select the option that expresses the given sentence in passive voice.
They asked me my name.

- Ans
- 1. I was asked my name.
 - 2. I was asked by them of my name.
 - 3. My name is asked by them.
 - 4. My name was asked from me.

Question ID : 264330137197
Option 1 ID : 264330537433
Option 2 ID : 264330537434
Option 3 ID : 264330537431
Option 4 ID : 264330537432
Status : Answered
Chosen Option : 1

Q.14 Select the most appropriate option to fill in the blank.

The teacher _____ everything at the end of the class.

- Ans
- 1. quenches
 - 2. recapitulates
 - 3. deceives
 - 4. usurps

Question ID : 264330164614
Option 1 ID : 264330645639
Option 2 ID : 264330645642
Option 3 ID : 264330645641
Option 4 ID : 264330645640
Status : Answered
Chosen Option : 2

Q.15 Select the most appropriate ANTONYM of the bracketed word in the following sentence to fill in the blank.

The meadow was a _____ (wild) site, far removed from the main roads and present-day habitation.

- Ans
- 1. strong
 - 2. frantic
 - 3. enraged
 - 4. tranquil

Question ID : 264330163508
Option 1 ID : 264330641293
Option 2 ID : 264330641291
Option 3 ID : 264330641292
Option 4 ID : 264330641294
Status : Answered
Chosen Option : 4

Q.16 Select the most appropriate option to fill in the blank.

Yoga increases physical and mental vitality, _____ to sickness, and overall well-being.

- Ans
- 1. assistance
 - 2. competence
 - 3. resistance
 - 4. acceptance

Question ID : 26433098918
Option 1 ID : 264330388325
Option 2 ID : 264330388326
Option 3 ID : 264330388328
Option 4 ID : 264330388327
Status : Answered
Chosen Option : 3

Q.17 Sentences of a paragraph are given below in jumbled order. Arrange the sentences in the correct order to form a meaningful and coherent paragraph.

- A. On 13 January 1928, the press was presented with this scientific achievement, which made the front pages of several major national newspapers.
- B. These were all in research labs.
- C. On 7 September 1927, Philo Farnsworth broadcasted the first 'television' system.
- D. Needless to say, a straight line was not mass marketable, therefore there were only a few dozen televisions in the globe by the end of the 1920s.

- Ans
- 1. CABD
 - 2. BDAC
 - 3. CADB
 - 4. BCAD

Question ID : 26433097522
Option 1 ID : 264330382762
Option 2 ID : 264330382763
Option 3 ID : 264330382761
Option 4 ID : 264330382764
Status : Answered
Chosen Option : 3

Q.18 Sentences of a paragraph are given below in jumbled order. Arrange the sentences in the correct order to form a meaningful and coherent paragraph.

- A. The expansion of education in English, the language of modern science, during British rule was extremely beneficial to Indian science.
- B. The creation of three universities in Calcutta, Bombay, and Madras in 1857 gave the study of science a boost.
- C. The first scientific research facility was established in Calcutta in 1876 by a wealthy doctor, Mahendra Lal Sircar. It was called the Indian organisation for the growth of science.
- D. It quickly began to dominate scientific endeavours in India before independence.

- Ans
- 1. ABCD
 - 2. ABDC
 - 3. ADBC
 - 4. ACDB

Question ID : 26433098148
Option 1 ID : 264330385247
Option 2 ID : 264330385246
Option 3 ID : 264330385248
Option 4 ID : 264330385245
Status : Answered
Chosen Option : 2

Q.19 Select the option that can be used as a one-word substitute for the underlined words.
It was his love and goodwill to humanity, that was recognised by the state government.

- Ans
- 1. misanthropy
 - 2. affection
 - 3. philanthropy
 - 4. humanism

Question ID : 264330117083
Option 1 ID : 264330460413
Option 2 ID : 264330460416
Option 3 ID : 264330460414
Option 4 ID : 264330460415
Status : Answered
Chosen Option : 3

Q.20 Select the most appropriate synonym of the underlined word in the following sentence.
The professor's lecture was filled with profound insights on the subject matter.

- Ans
- 1. Deep
 - 2. Shallow
 - 3. Superficial
 - 4. Accidental

Question ID : 264330164641
Option 1 ID : 264330645744
Option 2 ID : 264330645743
Option 3 ID : 264330645746
Option 4 ID : 264330645745
Status : Answered
Chosen Option : 2

Q.21 Select the option that changes the form of narration in the following sentence.

My father said, "Change is the only constant in life."

- Ans
- 1. My father said that change is the only constant in life.
 - 2. My father had said that change was the only constant in life.
 - 3. My father advised that change had been the only constant in life.
 - 4. My father said that change was the only constant in life.

Question ID : 264330163265
Option 1 ID : 264330640374
Option 2 ID : 264330640373
Option 3 ID : 264330640372
Option 4 ID : 264330640371
Status : Answered
Chosen Option : 1

Q.22 Select the most appropriate option that can substitute the underlined segment in the given sentence. If there is no need to substitute it, select 'No substitution'.

Not only the manager give me a refund, but he also offered me a 50% discount on my next meal.

- Ans
- 1. Not only do the manager give me a refund,
 - 2. No substitution
 - 3. Not only did the manager give me a refund,
 - 4. Not only did the manager gave me a refund,

Question ID : 264330101027
Option 1 ID : 264330396653
Option 2 ID : 264330396656
Option 3 ID : 264330396655
Option 4 ID : 264330396654
Status : Answered
Chosen Option : 2

Q.23 Select the most appropriate meaning of the given idiom.
Still waters run deep

- Ans
- 1. To have passion or great intelligence underneath a calm expression
 - 2. To be confused or not understand something
 - 3. Desperate measures made in order to come out of a difficult situation
 - 4. A very serious situation

Question ID : 264330165265
Option 1 ID : 264330648153
Option 2 ID : 264330648152
Option 3 ID : 264330648151
Option 4 ID : 264330648154
Status : Answered
Chosen Option : 1

Q.24 Select the option that expresses the given sentence in reported speech.
Mrs. Batra said, "My son wants to study Architecture."

- Ans
- 1. Mrs. Batra said that her son wanted to study Architecture.
 - 2. Mrs. Batra said that her son wanting to study Architecture.
 - 3. Mrs. Batra said that her son want to study Architecture.
 - 4. Mrs. Batra said that her son went to study Architecture.

Question ID : 264330139317
Option 1 ID : 264330545761
Option 2 ID : 264330545759
Option 3 ID : 264330545760
Option 4 ID : 264330545762
Status : Answered
Chosen Option : 1

Q.25 Parts of the following sentence have been given as options. Select the option that contains an error.

I couldn't hear your voice as you were too far out from me.

- Ans
- 1. you were too
 - 2. I couldn't hear
 - 3. your voice as
 - 4. far out from me

Question ID : 264330134128

Option 1 ID : 264330525537

Option 2 ID : 264330525535

Option 3 ID : 264330525536

Option 4 ID : 264330525538

Status : Answered

Chosen Option : 1

Q.26 Select the option that expresses the given sentence in active voice.
In Japan, thousands of people were killed in the tsunami last week.

- Ans
- 1. The tsunami have killed thousands of people in Japan last week.
 - 2. The tsunami had killed thousands of people last week in Japan.
 - 3. The tsunami has killed thousands of people last week in Japan.
 - 4. The tsunami last week killed thousands of people in Japan.

Question ID : 264330120580

Option 1 ID : 264330472566

Option 2 ID : 264330472564

Option 3 ID : 264330472565

Option 4 ID : 264330472563

Status : Answered

Chosen Option : 4

Q.27 Select the most appropriate idiom to replace the underlined group of words in the given sentence.

It was apparent that she was faking sorrow at the death of her stepdaughter.

- Ans
- 1. biting her own tongue
 - 2. cutting mustard
 - 3. calling a spade, a spade
 - 4. shedding crocodile tears

Question ID : 264330122277

Option 1 ID : 264330479236

Option 2 ID : 264330479238

Option 3 ID : 264330479235

Option 4 ID : 264330479237

Status : Answered

Chosen Option : 4

Q.28 Select the option that expresses the following sentence in reported (or indirect) speech.

They said, "We will come home this evening."

- Ans
- 1. They said that they would come home that evening.
 - 2. They said that they will come home that evening.
 - 3. They said that they would be coming home this evening.
 - 4. They said that they would come be coming home that evening.

Question ID : 264330164347

Option 1 ID : 264330644600

Option 2 ID : 264330644601

Option 3 ID : 264330644599

Option 4 ID : 264330644602

Status : Answered

Chosen Option : 1

Q.29 Select the option that expresses the given sentence in passive voice.

The police had collected the primary evidence before they arrested the culprit.

- Ans
- 1. The primary evidence had been collected by the police before the culprit was arrested.
 - 2. The primary evidence had collected by the police before the culprit was arrested.
 - 3. The primary evidence was collected by the police before the culprit was arrested.
 - 4. The primary evidence might have been collected by the police before the culprit was arrested.

Question ID : 264330136444

Option 1 ID : 264330534537

Option 2 ID : 264330534538

Option 3 ID : 264330534535

Option 4 ID : 264330534536

Status : Answered

Chosen Option : 1

Q.30 Select the most appropriate meaning of the underlined idiom.
It turned out to be a wild-goose chase for the police.

- Ans
- 1. Engage patiently
 - 2. Fruitless pursuit or search
 - 3. Hastily jump to conclusions
 - 4. Fruitful pursuit or search

Question ID : 264330164278

Option 1 ID : 264330644336

Option 2 ID : 264330644335

Option 3 ID : 264330644338

Option 4 ID : 264330644337

Status : Answered

Chosen Option : 2

Q.31 The following sentence has been split into four segments. Identify the segment that contains a grammatical error.

They / was / reading / a notice.

- Ans
- 1. was
 - 2. a notice
 - 3. reading
 - 4. They

Question ID : 26433094744
Option 1 ID : 264330371810
Option 2 ID : 264330371812
Option 3 ID : 264330371811
Option 4 ID : 264330371809
Status : Answered
Chosen Option : 1

Q.32 Select the most appropriate option that can substitute the underlined segment in the given sentence.
Nobody knew Ramesh was coming to see us. He arrived suddenly.

- Ans
- 1. safely
 - 2. happily
 - 3. angrily
 - 4. unexpectedly

Question ID : 264330120555
Option 1 ID : 264330472465
Option 2 ID : 264330472463
Option 3 ID : 264330472464
Option 4 ID : 264330472466
Status : Answered
Chosen Option : 4

Q.33 The following sentence has been split into four segments. Identify the segment that contains a grammatical error.
Don't let the failure / demotivate you as / failures are the / stepping stones to success.

- Ans
- 1. stepping stones to success
 - 2. demotivate you as
 - 3. failures are the
 - 4. Don't let the failure

Question ID : 264330137225
Option 1 ID : 264330537534
Option 2 ID : 264330537532
Option 3 ID : 264330537533
Option 4 ID : 264330537531
Status : Answered
Chosen Option : 2

Q.34 Select the correct direct narration of the given sentence.
Ramu requested her to wait there till he returned.

- Ans
- 1. Ramu said to her, "Please wait here till I return".
 - 2. Ramu say to her, "Please wait here till he returns".
 - 3. Ramu says to her, "Please wait here till he return".
 - 4. Ramu say to her, "Please wait here till I return".

Question ID : 264330132880
Option 1 ID : 264330520589
Option 2 ID : 264330520590
Option 3 ID : 264330520588
Option 4 ID : 264330520587
Status : Answered
Chosen Option : 1

Q.35 Select the most appropriate option that can substitute the underlined segment in the given sentence.
I have been calling him from many days.

- Ans
- 1. since
 - 2. of
 - 3. about
 - 4. for

Question ID : 264330117255
Option 1 ID : 264330461078
Option 2 ID : 264330461079
Option 3 ID : 264330461080
Option 4 ID : 264330461077
Status : Answered
Chosen Option : 4

Q.36 The following sentence has been divided into parts. One of them may contain an error. Select the part that contains the error from the given options. If you don't find any error, mark 'No error' as your answer.

He had been improve / his communication skills in order / to shine in his career.

- Ans
- 1. No error
 - 2. He had been improve
 - 3. to shine in his career
 - 4. his communication skills in order

Question ID : 26433089019
Option 1 ID : 264330349616
Option 2 ID : 264330349613
Option 3 ID : 264330349615
Option 4 ID : 264330349614
Status : Answered
Chosen Option : 2

Q.37 Select the most appropriate option that can substitute the underlined segment in the given sentence. If there is no need to substitute it, select 'No substitution'.

Unless he has permission from his parents, he wouldn't travel alone.

- Ans
- 1. Unless he had permission from his parents,
 - 2. If he had permission from his parents,
 - 3. Unless he had permitted by his parents,
 - 4. No substitution

Question ID : 264330101028
Option 1 ID : 264330396657
Option 2 ID : 264330396658
Option 3 ID : 264330396659
Option 4 ID : 264330396660
Status : Answered
Chosen Option : 3

Q.38 Select the most appropriate meaning of the given idiom.
Hornet's nest

- Ans
- 1. Difficult and unpleasant situation
 - 2. Filthy and shabby appearance
 - 3. A treasure full of wealth
 - 4. Happy and enjoyable moments

Question ID : 264330169782
Option 1 ID : 264330665821
Option 2 ID : 264330665819
Option 3 ID : 264330665822
Option 4 ID : 264330665820
Status : Answered
Chosen Option : 1

Q.39 Select the most appropriate option to complete the idiom in the given sentence.
I have been _____ over the two options in my head and I think we should go with the first one.

- Ans
- 1. looking
 - 2. obsessing
 - 3. mulling
 - 4. seeing

Question ID : 264330165266
Option 1 ID : 264330648155
Option 2 ID : 264330648157
Option 3 ID : 264330648158
Option 4 ID : 264330648156
Status : Answered
Chosen Option : 2

Q.40 Select the most appropriate ANTONYM of the given word.
Border

- Ans 1. Boundary
 2. Centre
 3. Partition
 4. Surface

Question ID : 264330168300
Option 1 ID : 264330660066
Option 2 ID : 264330660065
Option 3 ID : 264330660064
Option 4 ID : 264330660063
Status : Answered
Chosen Option : 2

Q.41 Select the most appropriate option that can substitute the underlined segment in the given sentence. If there is no need to substitute it, select 'No substitution required'.
The corner of the street where my family lived is surround by investigators.

- Ans 1. where my family live was surrounded by investigators
 2. where my family lives is surround by investigators
 3. No substitution required
 4. where my family lives is surrounded by investigators

Question ID : 264330117053
Option 1 ID : 264330460293
Option 2 ID : 264330460295
Option 3 ID : 264330460296
Option 4 ID : 264330460294
Status : Answered
Chosen Option : 4

Q.42 Sentences of a paragraph are given below in jumbled order. Arrange the sentences in the correct order to form a meaningful and coherent paragraph.

- A. Before a man could even construct a home for himself or weave clothing to protect his body, he was creative instinctively.
B. Many researchers have done studies to know more about pre historic times.
C. He made use of a sharp stone. Unaware of it, civilisation had started in a unique way.
D. On the cave walls, man penned, or more accurately scratched rudimentary images.

- Ans 1. BADC
 2. DBAC
 3. ABCD
 4. CBDA

Question ID : 26433098146
Option 1 ID : 264330385237
Option 2 ID : 264330385240
Option 3 ID : 264330385238
Option 4 ID : 264330385239
Status : Answered
Chosen Option : 3

Q.43 The following sentence has been split into four segments. Identify the segment that contains a grammatical error.
Are you sure that / you will be broadcast / the news to everyone / across the country?

- Ans
- 1. across the country
 - 2. the news to everyone
 - 3. you will be broadcast
 - 4. Are you sure that

Question ID : 264330133411
Option 1 ID : 264330522678
Option 2 ID : 264330522677
Option 3 ID : 264330522676
Option 4 ID : 264330522675
Status : Answered
Chosen Option : 3

Q.44 The following sentence has been split into four segments. Identify the segment that contains a grammatical error.
You will not invited / to any function / by them / if you don't attend the marriage.

- Ans
- 1. You will not invited
 - 2. to any function
 - 3. by them
 - 4. if you don't attend the marriage

Question ID : 264330132811
Option 1 ID : 264330520331
Option 2 ID : 264330520332
Option 3 ID : 264330520333
Option 4 ID : 264330520334
Status : Answered
Chosen Option : 1

Q.45 Select the most appropriate synonym of the given word.
Commotion

- Ans
- 1. Conflict
 - 2. Issue
 - 3. Bustle
 - 4. Absurd

Question ID : 264330165243
Option 1 ID : 264330648071
Option 2 ID : 264330648073
Option 3 ID : 264330648072
Option 4 ID : 264330648074
Status : Answered
Chosen Option : 4

Q.46 Select the option that expresses the given sentence in active voice.
His gold ornaments were stolen by a thief.

- Ans 1. A thief had stolen his gold ornaments.
 2. A thief has stolen his gold ornaments.
 3. A thief stole his gold ornaments.
 4. A thief have stolen his gold ornaments.

Question ID : 264330164356
Option 1 ID : 264330644638
Option 2 ID : 264330644636
Option 3 ID : 264330644635
Option 4 ID : 264330644637
Status : Answered
Chosen Option : 3

Q.47 Sentences of a paragraph are given below in jumbled order. Arrange the sentences in the correct order to form a meaningful and coherent paragraph.

- A. Even getting what they want doesn't satisfy some kids; they only want more.
B. Too many parents these days can't say no.
C. The struggle to set limits has never been tougher—and the stakes have never been higher.
D. As a result, they find themselves raising children who respond greedily to the advertisements aimed right at them.

- Ans 1. BDCA
 2. CDBA
 3. BDAC
 4. CABD

Question ID : 26433098959
Option 1 ID : 264330388488
Option 2 ID : 264330388486
Option 3 ID : 264330388485
Option 4 ID : 264330388487
Status : Answered
Chosen Option : 1

Q.48 The following sentence has been divided into parts. One of them may contain an error. Select the part that contains the error from the given options. If you don't find any error, mark 'No error' as your answer.

(1) She hang up / (2) the clothes / (3) in the closet every day. / (4) No error

- Ans 1. 2
 2. 1
 3. 3
 4. 4

Question ID : 264330164336
Option 1 ID : 264330644556
Option 2 ID : 264330644555
Option 3 ID : 264330644557
Option 4 ID : 264330644558
Status : Answered
Chosen Option : 3

Q.49 Select the option that expresses the given sentence in indirect speech.
My music teacher said to me, "You sing beautifully."

- Ans
- 1. My music teacher told me that I was singing beautifully.
 - 2. My music teacher told me that I had sung beautifully.
 - 3. My music teacher told me that I sang beautifully.
 - 4. My music teacher told me that I have sung beautifully.

Question ID : 26433059462
Option 1 ID : 264330232716
Option 2 ID : 264330232717
Option 3 ID : 264330232718
Option 4 ID : 264330232719
Status : Answered
Chosen Option : 3

Q.50 Select the most appropriate option to substitute the underlined segment in the given sentence.

When you will be award for your achievements?

- Ans
- 1. you will be awarded
 - 2. will you be award
 - 3. will you be awarded
 - 4. will you award

Question ID : 264330100294
Option 1 ID : 264330393741
Option 2 ID : 264330393743
Option 3 ID : 264330393742
Option 4 ID : 264330393744
Status : Answered
Chosen Option : 3

Q.51 Select the option that expresses the given sentence in direct speech.
The clerk requested the manager to sanction his leave.

- Ans
- 1. The clerk informed the manager, "Please sanction my leave".
 - 2. The clerk said to the manager, "Sanction leave".
 - 3. The clerk said to the manager, "Please sanction my leave".
 - 4. The clerk said to the manager, "Do you sanction leave?"

Question ID : 264330139160
Option 1 ID : 264330545216
Option 2 ID : 264330545217
Option 3 ID : 264330545215
Option 4 ID : 264330545218
Status : Answered
Chosen Option : 3

Q.52 Select the option that expresses the given sentence in indirect speech.
Donny said, "I can swim fast."

- Ans** ✓ 1. Donny said that she could swim fast.
✗ 2. Donny said that she had swum fast.
✗ 3. Donny said that she could not swim fast.
✗ 4. Donny said that she will swim fast.

Question ID : 264330164267
Option 1 ID : 264330644293
Option 2 ID : 264330644294
Option 3 ID : 264330644291
Option 4 ID : 264330644292
Status : Answered
Chosen Option : 1

Q.53 Select the most appropriate ANTONYM of the given word.
Plight

- Ans** ✗ 1. Travel
✗ 2. Trouble
✓ 3. Benefit
✗ 4. Land

Question ID : 264330168277
Option 1 ID : 264330659978
Option 2 ID : 264330659975
Option 3 ID : 264330659976
Option 4 ID : 264330659977
Status : Not Answered
Chosen Option : --

Q.54 Select the most appropriate ANTONYM of the given word.
Zenith

- Ans** ✗ 1. Summit
✓ 2. Bottom
✗ 3. Heaviness
✗ 4. Astonishment

Question ID : 264330168279
Option 1 ID : 264330659983
Option 2 ID : 264330659984
Option 3 ID : 264330659985
Option 4 ID : 264330659986
Status : Answered
Chosen Option : 2

Q.55 Select the option that expresses the given sentence in passive voice.
How can Sameer do silly mistakes in the office?

- Ans
- 1. How silly mistakes could be done by Sameer in the office?
 - 2. How silly mistakes could have done by Sameer in the office?
 - 3. How can silly mistakes be done by Sameer in the office?
 - 4. How silly mistakes are done by Sameer in the office?

Question ID : 264330164621
Option 1 ID : 264330645663
Option 2 ID : 264330645666
Option 3 ID : 264330645665
Option 4 ID : 264330645664
Status : Answered
Chosen Option : 3

Q.56 Select the most appropriate synonym of the given word.
Modest

- Ans
- 1. Arrogant
 - 2. Demure
 - 3. Petty
 - 4. Lucid

Question ID : 264330137240
Option 1 ID : 264330537594
Option 2 ID : 264330537593
Option 3 ID : 264330537591
Option 4 ID : 264330537592
Status : Answered
Chosen Option : 1

Q.57 Select the option that expresses the given sentence in passive voice.
Alisha posted the picture online.

- Ans
- 1. The picture is being posted online by Alisha.
 - 2. The picture has been posted online by Alisha.
 - 3. The picture is posted online by Alisha.
 - 4. The picture was posted online by Alisha.

Question ID : 264330168329
Option 1 ID : 264330660181
Option 2 ID : 264330660180
Option 3 ID : 264330660179
Option 4 ID : 264330660182
Status : Answered
Chosen Option : 4

Q.58 The following sentence has been split into four segments. Identify the segment that contains a grammatical error.

Bikanervala is a restaurant / chain in India / that is now famous / all ahead the world.

- Ans
- 1. that is now famous
 - 2. chain in India
 - 3. Bikanervala is a restaurant
 - 4. all ahead the world.

Question ID : 26433096143
Option 1 ID : 264330377343
Option 2 ID : 264330377342
Option 3 ID : 264330377341
Option 4 ID : 264330377344
Status : Answered
Chosen Option : 4

Q.59 Select the most appropriate option to fill in the blank.

Turn the lights _____, I want to go to sleep.

- Ans
- 1. off
 - 2. down
 - 3. on
 - 4. up

Question ID : 26433098898
Option 1 ID : 264330388246
Option 2 ID : 264330388247
Option 3 ID : 264330388245
Option 4 ID : 264330388248
Status : Answered
Chosen Option : 1

Q.60 Select the option that expresses the following sentence in active voice.
The melody has been composed wonderfully by Kayra.

- Ans
- 1. Kayra has been composing the melody wonderfully.
 - 2. Kayra has composed the melody wonderfully.
 - 3. Kayra wonderfully composed the melody.
 - 4. Kayra had composed the melody wonderfully.

Question ID : 264330164320
Option 1 ID : 264330644497
Option 2 ID : 264330644498
Option 3 ID : 264330644496
Option 4 ID : 264330644495
Status : Answered
Chosen Option : 2

Q.61 Select the most appropriate option that can substitute the underlined segment in the given sentence. If there is no need to substitute it, select 'No substitution required'.
After working for the entire week we usually go out to eat on Sundays.

- Ans 1. at Sundays
 2. No substitution required
 3. on Sunday
 4. at Sunday

Question ID : 264330100306
 Option 1 ID : 264330393790
 Option 2 ID : 264330393792
 Option 3 ID : 264330393791
 Option 4 ID : 264330393789
 Status : Answered
 Chosen Option : 3

Q.62 Select the option that expresses the given sentence in direct speech.
The teacher said that if we studied hard, we would do well in the exam and that she would be proud of us.

- Ans 1. "If we studied hard, we would do well on the exam, and the teacher would be proud of us," said the teacher.
 2. "If you studied hard, you would do well on the exam, and I would be proud of you," said the teacher.
 3. "I will be proud of you if you study hard and do well on the exam," said the teacher.
 4. "If you study hard, you will do well in the exam, and I will be proud of you," said the teacher.

Question ID : 264330165107
 Option 1 ID : 264330647558
 Option 2 ID : 264330647557
 Option 3 ID : 264330647556
 Option 4 ID : 264330647555
 Status : Answered
 Chosen Option : 4

Q.63 Sentences of a paragraph are given below in jumbled order. Arrange the sentences in the correct order to form a meaningful and coherent paragraph.

- A. The task of feeding the brood is left to the lady birds.
 B. The birds arrive and choose their nest after careful inspection.
 C. They pick the location and begin weaving their bottle-shaped nests out of coarse grass and paddy leaves.
 D. Male birds serve as the principal architects and craftsman in the colony of weaver birds.

- Ans 1. BACD
 2. CDAB
 3. ABCD
 4. DCBA

Question ID : 26433098154
 Option 1 ID : 264330385272
 Option 2 ID : 264330385270
 Option 3 ID : 264330385269
 Option 4 ID : 264330385271
 Status : Answered
 Chosen Option : 2

Q.64 Select the most appropriate synonym of the bracketed word in the following sentence to fill in the blank.

The new student hails from the _____ societies of the Eastern India. (affluent)

- Ans
- 1. famous
 - 2. clever
 - 3. harmless
 - 4. wealthy

Question ID : 264330163273
Option 1 ID : 264330640403
Option 2 ID : 264330640406
Option 3 ID : 264330640404
Option 4 ID : 264330640405
Status : Answered
Chosen Option : 4

Q.65 Parts of a sentence/paragraph are given below. While the first and the last parts (A and F) are in the correct order, the parts in between are jumbled up. Arrange the parts in the correct order to form a meaningful and coherent sentence/paragraph.

- A.If you complete one of your assignments early
- B.do not work on any other assignment
- C.go back through that assignment only
- D.if you are found working on another assignment
- E.this is not permitted
- F.Your contract will be terminated .

- Ans
- 1. C, B, E, D
 - 2. C, D, E, B
 - 3. B, C, D, E
 - 4. E, B, C, D

Question ID : 26433099084
Option 1 ID : 264330388970
Option 2 ID : 264330388972
Option 3 ID : 264330388969
Option 4 ID : 264330388971
Status : Answered
Chosen Option : 4

Comprehension:

In the following passage, some words have been deleted. Read the passage carefully and select the most appropriate option to fill in each blank.

A (1)_____ is a type of attack in which an attacker attempts to gain access to a user's sensitive information by posing as a trustworthy entity. Phishing attacks can take many forms, including email, text message, or phone call scams. To protect against phishing attacks, it's important to be (2)_____ of the warning signs, such as requests for personal information or suspicious links. Other strategies include using anti-phishing software and staying up-to-date on the latest (3)_____. If you suspect that you've fallen victim to a phishing attack, it's important to take (4)_____ as soon as possible. Despite the risks associated with phishing, many people continue to fall prey to these scams, underscoring the importance of (5)_____ and caution when using the internet.

SubQuestion No : 66

Q.66 Select the most appropriate option to fill in blank 1.

- Ans
- 1. firewall
 - 2. spam
 - 3. phishing
 - 4. virus

Question ID : 264330166366

Option 1 ID : 264330652520

Option 2 ID : 264330652521

Option 3 ID : 264330652522

Option 4 ID : 264330652519

Status : **Answered**

Chosen Option : 3

Comprehension:

In the following passage, some words have been deleted. Read the passage carefully and select the most appropriate option to fill in each blank.

A (1)_____ is a type of attack in which an attacker attempts to gain access to a user's sensitive information by posing as a trustworthy entity. Phishing attacks can take many forms, including email, text message, or phone call scams. To protect against phishing attacks, it's important to be (2)_____ of the warning signs, such as requests for personal information or suspicious links. Other strategies include using anti-phishing software and staying up-to-date on the latest (3)_____. If you suspect that you've fallen victim to a phishing attack, it's important to take (4)_____ as soon as possible. Despite the risks associated with phishing, many people continue to fall prey to these scams, underscoring the importance of (5)_____ and caution when using the internet.

SubQuestion No : 67

Q.67 Select the most appropriate option to fill in blank 2.

- Ans
- 1. negligent
 - 2. aware
 - 3. doubtful
 - 4. indifferent

Question ID : 264330166367

Option 1 ID : 264330652524

Option 2 ID : 264330652523

Option 3 ID : 264330652525

Option 4 ID : 264330652526

Status : **Answered**

Chosen Option : 2

Comprehension:

In the following passage, some words have been deleted. Read the passage carefully and select the most appropriate option to fill in each blank.

A (1)_____ is a type of attack in which an attacker attempts to gain access to a user's sensitive information by posing as a trustworthy entity. Phishing attacks can take many forms, including email, text message, or phone call scams. To protect against phishing attacks, it's important to be (2)_____ of the warning signs, such as requests for personal information or suspicious links. Other strategies include using anti-phishing software and staying up-to-date on the latest (3)_____. If you suspect that you've fallen victim to a phishing attack, it's important to take (4)_____ as soon as possible. Despite the risks associated with phishing, many people continue to fall prey to these scams, underscoring the importance of (5)_____ and caution when using the internet.

SubQuestion No : 68

Q.68 Select the most appropriate option to fill in blank 3.

- Ans
- 1. bugs
 - 2. vulnerabilities
 - 3. updates
 - 4. patches

Question ID : 264330166368

Option 1 ID : 264330652528

Option 2 ID : 264330652527

Option 3 ID : 264330652530

Option 4 ID : 264330652529

Status : Answered

Chosen Option : 3

Comprehension:

In the following passage, some words have been deleted. Read the passage carefully and select the most appropriate option to fill in each blank.

A (1)_____ is a type of attack in which an attacker attempts to gain access to a user's sensitive information by posing as a trustworthy entity. Phishing attacks can take many forms, including email, text message, or phone call scams. To protect against phishing attacks, it's important to be (2)_____ of the warning signs, such as requests for personal information or suspicious links. Other strategies include using anti-phishing software and staying up-to-date on the latest (3)_____. If you suspect that you've fallen victim to a phishing attack, it's important to take (4)_____ as soon as possible. Despite the risks associated with phishing, many people continue to fall prey to these scams, underscoring the importance of (5)_____ and caution when using the internet.

SubQuestion No : 69

Q.69 Select the most appropriate option to fill in blank 4.

- Ans
- 1. risks
 - 2. advantages
 - 3. measures
 - 4. disadvantages

Question ID : 264330166369

Option 1 ID : 264330652531

Option 2 ID : 264330652533

Option 3 ID : 264330652532

Option 4 ID : 264330652534

Status : Answered

Chosen Option : 3

Comprehension:

In the following passage, some words have been deleted. Read the passage carefully and select the most appropriate option to fill in each blank.

A (1)_____ is a type of attack in which an attacker attempts to gain access to a user's sensitive information by posing as a trustworthy entity. Phishing attacks can take many forms, including email, text message, or phone call scams. To protect against phishing attacks, it's important to be (2)_____ of the warning signs, such as requests for personal information or suspicious links. Other strategies include using anti-phishing software and staying up-to-date on the latest (3)_____. If you suspect that you've fallen victim to a phishing attack, it's important to take (4)_____ as soon as possible. Despite the risks associated with phishing, many people continue to fall prey to these scams, underscoring the importance of (5)_____ and caution when using the internet.

SubQuestion No : 70

Q.70 Select the most appropriate option to fill in blank 5.

- Ans 1. vigilance
 2. scepticism
 3. curiosity
 4. complacency

Question ID : 264330166370
Option 1 ID : 264330652538
Option 2 ID : 264330652535
Option 3 ID : 264330652536
Option 4 ID : 264330652537
Status : Answered
Chosen Option : 1

Comprehension:

In the following passage, some words have been deleted. Read the passage carefully and select the most appropriate option to fill in each blank.

A man is not bad (1)_____ birth but circumstances make him bad. He was a kind man and wanted to join a (2)_____ circus. His ambition was not fulfilled (3)_____ his parents did not agree. He held his family and society (4)_____ for the frustration of his dreams. Therefore, he became (5)_____ with everyone.

SubQuestion No : 71

Q.71 Select the most appropriate option to fill in blank 1.

- Ans 1. by
 2. for
 3. at
 4. from

Question ID : 264330167891
Option 1 ID : 264330658493
Option 2 ID : 264330658494
Option 3 ID : 264330658491
Option 4 ID : 264330658492
Status : Answered
Chosen Option : 1

Comprehension:

In the following passage, some words have been deleted. Read the passage carefully and select the most appropriate option to fill in each blank.

A man is not bad (1) _____ birth but circumstances make him bad. He was a kind man and wanted to join a (2) _____ circus. His ambition was not fulfilled (3) _____ his parents did not agree. He held his family and society (4) _____ for the frustration of his dreams. Therefore, he became (5) _____ with everyone.

SubQuestion No : 72

Q.72 Select the most appropriate option to fill in blank 2.

- Ans 1. rescuing
 2. tour
 3. furnishing
 4. travelling

Question ID : 264330167892

Option 1 ID : 264330658497

Option 2 ID : 264330658495

Option 3 ID : 264330658496

Option 4 ID : 264330658498

Status : Answered

Chosen Option : 4

Comprehension:

In the following passage, some words have been deleted. Read the passage carefully and select the most appropriate option to fill in each blank.

A man is not bad (1) _____ birth but circumstances make him bad. He was a kind man and wanted to join a (2) _____ circus. His ambition was not fulfilled (3) _____ his parents did not agree. He held his family and society (4) _____ for the frustration of his dreams. Therefore, he became (5) _____ with everyone.

SubQuestion No : 73

Q.73 Select the most appropriate option to fill in blank 3.

- Ans 1. any
 2. while
 3. as
 4. thus

Question ID : 264330167893

Option 1 ID : 264330658502

Option 2 ID : 264330658501

Option 3 ID : 264330658500

Option 4 ID : 264330658499

Status : Answered

Chosen Option : 2

Comprehension:

In the following passage, some words have been deleted. Read the passage carefully and select the most appropriate option to fill in each blank.

A man is not bad (1) _____ birth but circumstances make him bad. He was a kind man and wanted to join a (2) _____ circus. His ambition was not fulfilled (3) _____ his parents did not agree. He held his family and society (4) _____ for the frustration of his dreams. Therefore, he became (5) _____ with everyone.

SubQuestion No : 74

Q.74 Select the most appropriate option to fill in blank 4.

- Ans
- 1. righteous
 - 2. noteworthy
 - 3. responsible
 - 4. abiding

Question ID : 264330167894

Option 1 ID : 264330658506

Option 2 ID : 264330658505

Option 3 ID : 264330658504

Option 4 ID : 264330658503

Status : Answered

Chosen Option : 3

Comprehension:

In the following passage, some words have been deleted. Read the passage carefully and select the most appropriate option to fill in each blank.

A man is not bad (1) _____ birth but circumstances make him bad. He was a kind man and wanted to join a (2) _____ circus. His ambition was not fulfilled (3) _____ his parents did not agree. He held his family and society (4) _____ for the frustration of his dreams. Therefore, he became (5) _____ with everyone.

SubQuestion No : 75

Q.75 Select the most appropriate option to fill in blank 5.

- Ans
- 1. sociable
 - 2. inimical
 - 3. aloof
 - 4. amiable

Question ID : 264330167895

Option 1 ID : 264330658508

Option 2 ID : 264330658510

Option 3 ID : 264330658509

Option 4 ID : 264330658507

Status : Answered

Chosen Option : 2

Comprehension:

In the following passage, some words have been deleted. Read the passage carefully and select the most appropriate option to fill in each blank.

The expansive (1) _____ stretched as far as the eye could see, its vastness seeming endless. Majestic mountains towered in the distance, their peaks (2) _____ by a thin layer of snow. A gentle breeze whispered through the (3) _____ trees, rustling their vibrant leaves. The air (4) _____ the sweet fragrance of the flowers, filling the surroundings with a delightful aroma. As the sun began to set, the sky transformed into a radiant canvas, painted with (5) _____ of orange, pink, and gold.

SubQuestion No : 76

Q.76 Select the most appropriate option to fill in blank no. 1.

Ans 1. landscape

2. desert

3. park

4. sea

Question ID : 264330169753

Option 1 ID : 264330665709

Option 2 ID : 264330665708

Option 3 ID : 264330665710

Option 4 ID : 264330665707

Status : Answered

Chosen Option : 4

Comprehension:

In the following passage, some words have been deleted. Read the passage carefully and select the most appropriate option to fill in each blank.

The expansive (1) _____ stretched as far as the eye could see, its vastness seeming endless. Majestic mountains towered in the distance, their peaks (2) _____ by a thin layer of snow. A gentle breeze whispered through the (3) _____ trees, rustling their vibrant leaves. The air (4) _____ the sweet fragrance of the flowers, filling the surroundings with a delightful aroma. As the sun began to set, the sky transformed into a radiant canvas, painted with (5) _____ of orange, pink, and gold.

SubQuestion No : 77

Q.77 Select the most appropriate option to fill in blank no. 2.

Ans 1. spread

2. piled

3. filled

4. covered

Question ID : 264330169754

Option 1 ID : 264330665713

Option 2 ID : 264330665714

Option 3 ID : 264330665712

Option 4 ID : 264330665711

Status : Answered

Chosen Option : 4

Comprehension:

In the following passage, some words have been deleted. Read the passage carefully and select the most appropriate option to fill in each blank.

The expansive (1) _____ stretched as far as the eye could see, its vastness seeming endless. Majestic mountains towered in the distance, their peaks (2) _____ by a thin layer of snow. A gentle breeze whispered through the (3) _____ trees, rustling their vibrant leaves. The air (4) _____ the sweet fragrance of the flowers, filling the surroundings with a delightful aroma. As the sun began to set, the sky transformed into a radiant canvas, painted with (5) _____ of orange, pink, and gold.

SubQuestion No : 78

Q.78 Select the most appropriate option to fill in blank no. 3.

- Ans 1. lustrous
 2. withered
 3. shrivelled
 4. shrinking

Question ID : 264330169755

Option 1 ID : 264330665718

Option 2 ID : 264330665716

Option 3 ID : 264330665715

Option 4 ID : 264330665717

Status : Not Answered

Chosen Option : --

Comprehension:

In the following passage, some words have been deleted. Read the passage carefully and select the most appropriate option to fill in each blank.

The expansive (1) _____ stretched as far as the eye could see, its vastness seeming endless. Majestic mountains towered in the distance, their peaks (2) _____ by a thin layer of snow. A gentle breeze whispered through the (3) _____ trees, rustling their vibrant leaves. The air (4) _____ the sweet fragrance of the flowers, filling the surroundings with a delightful aroma. As the sun began to set, the sky transformed into a radiant canvas, painted with (5) _____ of orange, pink, and gold.

SubQuestion No : 79

Q.79 Select the most appropriate option to fill in blank no. 4.

- Ans 1. threw
 2. flung
 3. carried
 4. pushed

Question ID : 264330169756

Option 1 ID : 264330665720

Option 2 ID : 264330665722

Option 3 ID : 264330665719

Option 4 ID : 264330665721

Status : Answered

Chosen Option : 2

Comprehension:

In the following passage, some words have been deleted. Read the passage carefully and select the most appropriate option to fill in each blank.

The expansive (1) _____ stretched as far as the eye could see, its vastness seeming endless. Majestic mountains towered in the distance, their peaks (2) _____ by a thin layer of snow. A gentle breeze whispered through the (3) _____ trees, rustling their vibrant leaves. The air (4) _____ the sweet fragrance of the flowers, filling the surroundings with a delightful aroma. As the sun began to set, the sky transformed into a radiant canvas, painted with (5) _____ of orange, pink, and gold.

SubQuestion No : 80

Q.80 Select the most appropriate option to fill in blank no. 5.

- Ans 1. brushes
 2. hues
 3. sheets
 4. tins

Question ID : 264330169757
Option 1 ID : 264330665723
Option 2 ID : 264330665724
Option 3 ID : 264330665726
Option 4 ID : 264330665725
Status : Answered
Chosen Option : 1

Comprehension:

In the following passage, some words have been deleted. Read the passage carefully and select the most appropriate option to fill in each blank.

The (1) _____ traveller embarked on an exciting (2) _____ through uncharted lands, seeking adventure and discovery. Armed (3) _____ a tattered map and a curious spirit, he ventured into the dense forest, where the air was thick with the (4) _____ of wildlife that echoed through the trees. The path ahead was obscured by overgrown vegetation and tangled roots, challenging his every step. With unwavering (5) _____, he pushed forward, drawn by the allure of the unknown.

SubQuestion No : 81

Q.81 Select the most appropriate option to fill in blank no. 1.

- Ans 1. worried
 2. adventurous
 3. sleepy
 4. lazy

Question ID : 264330169759
Option 1 ID : 264330665730
Option 2 ID : 264330665729
Option 3 ID : 264330665728
Option 4 ID : 264330665727
Status : Answered
Chosen Option : 2

Comprehension:

In the following passage, some words have been deleted. Read the passage carefully and select the most appropriate option to fill in each blank.

The (1)_____ traveller embarked on an exciting (2)_____ through uncharted lands, seeking adventure and discovery. Armed (3)_____ a tattered map and a curious spirit, he ventured into the dense forest, where the air was thick with the (4)_____ of wildlife that echoed through the trees. The path ahead was obscured by overgrown vegetation and tangled roots, challenging his every step. With unwavering (5)_____, he pushed forward, drawn by the allure of the unknown.

SubQuestion No : 82**Q.82 Select the most appropriate option to fill in blank no. 2.**

- Ans
- 1. swim
 - 2. visit
 - 3. journey
 - 4. walk

Question ID : 264330169760

Option 1 ID : 264330665733

Option 2 ID : 264330665734

Option 3 ID : 264330665731

Option 4 ID : 264330665732

Status : Answered

Chosen Option : 2

Comprehension:

In the following passage, some words have been deleted. Read the passage carefully and select the most appropriate option to fill in each blank.

The (1)_____ traveller embarked on an exciting (2)_____ through uncharted lands, seeking adventure and discovery. Armed (3)_____ a tattered map and a curious spirit, he ventured into the dense forest, where the air was thick with the (4)_____ of wildlife that echoed through the trees. The path ahead was obscured by overgrown vegetation and tangled roots, challenging his every step. With unwavering (5)_____, he pushed forward, drawn by the allure of the unknown.

SubQuestion No : 83**Q.83 Select the most appropriate option to fill in blank no. 3.**

- Ans
- 1. with
 - 2. along
 - 3. in
 - 4. for

Question ID : 264330169761

Option 1 ID : 264330665737

Option 2 ID : 264330665736

Option 3 ID : 264330665738

Option 4 ID : 264330665735

Status : Answered

Chosen Option : 1

Comprehension:

In the following passage, some words have been deleted. Read the passage carefully and select the most appropriate option to fill in each blank.

The (1)_____ traveller embarked on an exciting (2)_____ through uncharted lands, seeking adventure and discovery. Armed (3)_____ a tattered map and a curious spirit, he ventured into the dense forest, where the air was thick with the (4)_____ of wildlife that echoed through the trees. The path ahead was obscured by overgrown vegetation and tangled roots, challenging his every step. With unwavering (5)_____, he pushed forward, drawn by the allure of the unknown.

SubQuestion No : 84

Q.84 Select the most appropriate option to fill in blank no. 4.

- Ans 1. sounds
 2. smell
 3. visuals
 4. touch

Question ID : 264330169762

Option 1 ID : 264330665741

Option 2 ID : 264330665739

Option 3 ID : 264330665742

Option 4 ID : 264330665740

Status : Answered

Chosen Option : 4

Comprehension:

In the following passage, some words have been deleted. Read the passage carefully and select the most appropriate option to fill in each blank.

The (1)_____ traveller embarked on an exciting (2)_____ through uncharted lands, seeking adventure and discovery. Armed (3)_____ a tattered map and a curious spirit, he ventured into the dense forest, where the air was thick with the (4)_____ of wildlife that echoed through the trees. The path ahead was obscured by overgrown vegetation and tangled roots, challenging his every step. With unwavering (5)_____, he pushed forward, drawn by the allure of the unknown.

SubQuestion No : 85

Q.85 Select the most appropriate option to fill in blank no. 5.

- Ans 1. protection
 2. realisation
 3. determination
 4. imagination

Question ID : 264330169763

Option 1 ID : 264330665745

Option 2 ID : 264330665746

Option 3 ID : 264330665744

Option 4 ID : 264330665743

Status : Answered

Chosen Option : 1

Comprehension:

Read the given passage and answer the questions that follow.

Is there a connection between the new spider found and Harry Potter, the popular boy wizard from JK Rowling's books? After spending months observing it in its fragile environment, a group of three Mumbai-based wildlife enthusiasts discovered a new species of spider, their very own Fantastic Beast, in Karnataka's Kants Forest in December 2016. The spider, which bears a striking resemblance to the Sorting Hat from JK Rowling's Harry Potter books, was given the name *Enenia gryffindori* by Rajashree Khalap, researcher Javed Ahmed, and wildlife photographer Sumukha Javagal. The name is both a reference to the Harry Potter series and a way to draw more attention to the eight-legged creatures. According to Javed, the spider uses the shape of the magical hat during the day to hide from predators and look like a dried leaf.

In fact, JK Rowling herself tweeted, "I'm truly honoured!" about it. Thank you for discovering yet another Fantastic Beast! Khalap, a conservationist who works for the wildlife non-profit Satpuda Foundation, claims that she identified with the main character of the film, Newt Scamander, and his desire to travel the world studying and protecting creatures. The announcement of the discovery came at the same time that the Harry Potter movie *Fantastic Beasts and Where to Find Them* was released. How could they understand that the dreadful little animal they had found had never been archived? It took a long time to observe. Sometimes they would catch one and release it back into the wild only to discover that it wasn't what they were looking for. They used a microscope to examine the spider and compare it to all of the species that were known to be in the same genus when they thought they had found the right one. In the past two years, Khalap and her naturalist and arachnologist partner Javed have discovered five new species of spiders. The *Paraplectana rajashree*, which is named after her, is one of these. It is a tiny nocturnal spider with a ladybird-like appearance. Khalap claims that the evolution of spiders fascinates her. Some of them live on leaves and are the same color as the leaves, while others live on tree trunks and completely blend in with the bark; Some, like the flower crab spiders, have evolved to look like their prey, while others, like the flower crab spiders, can even change colour.

SubQuestion No : 86

Q.86 Who wrote Harry Potter?

- Ans
- ✓ 1. JK Rowling
 - ✗ 2. Javed Ahmed
 - ✗ 3. Rajashree Khalap
 - ✗ 4. Sumukha Javagal

Question ID : 264330169245

Option 1 ID : 264330663759

Option 2 ID : 264330663762

Option 3 ID : 264330663761

Option 4 ID : 264330663760

Status : Answered

Chosen Option : 1

Comprehension:

Read the given passage and answer the questions that follow.

Is there a connection between the new spider found and Harry Potter, the popular boy wizard from JK Rowling's books? After spending months observing it in its fragile environment, a group of three Mumbai-based wildlife enthusiasts discovered a new species of spider, their very own Fantastic Beast, in Kamataka's Kans Forest in December 2016. The spider, which bears a striking resemblance to the Sorting Hat from JK Rowling's Harry Potter books, was given the name *Enenia gryffindori* by Rajashree Khalap, researcher Javed Ahmed, and wildlife photographer Sumukha Javagal. The name is both a reference to the Harry Potter series and a way to draw more attention to the eight-legged creatures. According to Javed, the spider uses the shape of the magical hat during the day to hide from predators and look like a dried leaf.

In fact, JK Rowling herself tweeted, "I'm truly honoured!" about it. Thank you for discovering yet another Fantastic Beast! Khalap, a conservationist who works for the wildlife non-profit Satpuda Foundation, claims that she identified with the main character of the film, Newt Scamander, and his desire to travel the world studying and protecting creatures. The announcement of the discovery came at the same time that the Harry Potter movie *Fantastic Beasts and Where to Find Them* was released. How could they understand that the dreadful little animal they had found had never been archived? It took a long time to observe. Sometimes they would catch one and release it back into the wild only to discover that it wasn't what they were looking for. They used a microscope to examine the spider and compare it to all of the species that were known to be in the same genus when they thought they had found the right one. In the past two years, Khalap and her naturalist and arachnologist partner Javed have discovered five new species of spiders. The *Paraplectana rajashree*, which is named after her, is one of these. It is a tiny nocturnal spider with a ladybird-like appearance. Khalap claims that the evolution of spiders fascinates her. Some of them live on leaves and are the same color as the leaves, while others live on tree trunks and completely blend in with the bark; Some, like the flower crab spiders, have evolved to look like their prey, while others, like the flower crab spiders, can even change colour.

SubQuestion No : 87

Q.87 Select the most appropriate synonym of the word 'evolution' in the context of the passage.

- Ans
- 1. Development
 - 2. Creation
 - 3. Raise
 - 4. Reversion

Question ID : 264330169248

Option 1 ID : 264330663772

Option 2 ID : 264330663771

Option 3 ID : 264330663774

Option 4 ID : 264330663773

Status : Answered

Chosen Option : 1

Comprehension:

Read the given passage and answer the questions that follow.

Is there a connection between the new spider found and Harry Potter, the popular boy wizard from JK Rowling's books? After spending months observing it in its fragile environment, a group of three Mumbai-based wildlife enthusiasts discovered a new species of spider, their very own Fantastic Beast, in Karnataka's Kants Forest in December 2016. The spider, which bears a striking resemblance to the Sorting Hat from JK Rowling's Harry Potter books, was given the name *Enenia gryffindori* by Rajashree Khalap, researcher Javed Ahmed, and wildlife photographer Sumukha Javagal. The name is both a reference to the Harry Potter series and a way to draw more attention to the eight-legged creatures. According to Javed, the spider uses the shape of the magical hat during the day to hide from predators and look like a dried leaf.

In fact, JK Rowling herself tweeted, "I'm truly honoured!" about it. Thank you for discovering yet another Fantastic Beast! Khalap, a conservationist who works for the wildlife non-profit Satpuda Foundation, claims that she identified with the main character of the film, Newt Scamander, and his desire to travel the world studying and protecting creatures. The announcement of the discovery came at the same time that the Harry Potter movie *Fantastic Beasts and Where to Find Them* was released. How could they understand that the dreadful little animal they had found had never been archived? It took a long time to observe. Sometimes they would catch one and release it back into the wild only to discover that it wasn't what they were looking for. They used a microscope to examine the spider and compare it to all of the species that were known to be in the same genus when they thought they had found the right one. In the past two years, Khalap and her naturalist and arachnologist partner Javed have discovered five new species of spiders. The *Paraplectana rajashree*, which is named after her, is one of these. It is a tiny nocturnal spider with a ladybird-like appearance. Khalap claims that the evolution of spiders fascinates her. Some of them live on leaves and are the same color as the leaves, while others live on tree trunks and completely blend in with the bark; Some, like the flower crab spiders, have evolved to look like their prey, while others, like the flower crab spiders, can even change colour.

SubQuestion No : 88

Q.88 Who works for Satpuda Foundation?

- Ans 1. Rajashree Khalap
 2. JK Rowling
 3. Javed Ahmed
 4. Sumukha Javagal

Question ID : 264330169246

Option 1 ID : 264330663765

Option 2 ID : 264330663763

Option 3 ID : 264330663766

Option 4 ID : 264330663764

Status : Answered

Chosen Option : 1

Comprehension:

Read the given passage and answer the questions that follow.

Is there a connection between the new spider found and Harry Potter, the popular boy wizard from JK Rowling's books? After spending months observing it in its fragile environment, a group of three Mumbai-based wildlife enthusiasts discovered a new species of spider, their very own Fantastic Beast, in Karnataka's Kansa Forest in December 2016. The spider, which bears a striking resemblance to the Sorting Hat from JK Rowling's Harry Potter books, was given the name *Enenia gryffindori* by Rajashree Khalap, researcher Javed Ahmed, and wildlife photographer Sumukha Javagal. The name is both a reference to the Harry Potter series and a way to draw more attention to the eight-legged creatures. According to Javed, the spider uses the shape of the magical hat during the day to hide from predators and look like a dried leaf.

In fact, JK Rowling herself tweeted, "I'm truly honoured!" about it. Thank you for discovering yet another Fantastic Beast! Khalap, a conservationist who works for the wildlife non-profit Satpuda Foundation, claims that she identified with the main character of the film, Newt Scamander, and his desire to travel the world studying and protecting creatures. The announcement of the discovery came at the same time that the Harry Potter movie *Fantastic Beasts and Where to Find Them* was released. How could they understand that the dreadful little animal they had found had never been archived? It took a long time to observe. Sometimes they would catch one and release it back into the wild only to discover that it wasn't what they were looking for. They used a microscope to examine the spider and compare it to all of the species that were known to be in the same genus when they thought they had found the right one. In the past two years, Khalap and her naturalist and arachnologist partner Javed have discovered five new species of spiders. The *Paraplectana rajashree*, which is named after her, is one of these. It is a tiny nocturnal spider with a ladybird-like appearance. Khalap claims that the evolution of spiders fascinates her. Some of them live on leaves and are the same color as the leaves, while others live on tree trunks and completely blend in with the bark; Some, like the flower crab spiders, have evolved to look like their prey, while others, like the flower crab spiders, can even change colour.

SubQuestion No : 89

Q.89 Select the most appropriate title for the passage.

- Ans 1. The Sorting Hat Spider
 2. The Discovery of a Spider
 3. Harry Potter and the Spider
 4. Spider and Legs

Question ID : 264330169244

Option 1 ID : 264330663757

Option 2 ID : 264330663756

Option 3 ID : 264330663758

Option 4 ID : 264330663755

Status : Answered

Chosen Option : 2

Comprehension:

Read the given passage and answer the questions that follow.

Is there a connection between the new spider found and Harry Potter, the popular boy wizard from JK Rowling's books? After spending months observing it in its fragile environment, a group of three Mumbai-based wildlife enthusiasts discovered a new species of spider, their very own Fantastic Beast, in Karnataka's Kansa Forest in December 2016. The spider, which bears a striking resemblance to the Sorting Hat from JK Rowling's Harry Potter books, was given the name *Enenia gryffindori* by Rajashree Khalap, researcher Javed Ahmed, and wildlife photographer Sumukha Javagal. The name is both a reference to the Harry Potter series and a way to draw more attention to the eight-legged creatures. According to Javed, the spider uses the shape of the magical hat during the day to hide from predators and look like a dried leaf.

In fact, JK Rowling herself tweeted, "I'm truly honoured!" about it. Thank you for discovering yet another Fantastic Beast! Khalap, a conservationist who works for the wildlife non-profit Satpuda Foundation, claims that she identified with the main character of the film, Newt Scamander, and his desire to travel the world studying and protecting creatures. The announcement of the discovery came at the same time that the Harry Potter movie *Fantastic Beasts and Where to Find Them* was released. How could they understand that the dreadful little animal they had found had never been archived? It took a long time to observe. Sometimes they would catch one and release it back into the wild only to discover that it wasn't what they were looking for. They used a microscope to examine the spider and compare it to all of the species that were known to be in the same genus when they thought they had found the right one. In the past two years, Khalap and her naturalist and arachnologist partner Javed have discovered five new species of spiders. The *Paraplectana rajashree*, which is named after her, is one of these. It is a tiny nocturnal spider with a ladybird-like appearance. Khalap claims that the evolution of spiders fascinates her. Some of them live on leaves and are the same color as the leaves, while others live on tree trunks and completely blend in with the bark; Some, like the flower crab spiders, have evolved to look like their prey, while others, like the flower crab spiders, can even change colour.

SubQuestion No : 90

Q.90 Based on your reading of the passage, select the correct statement.

- Ans
- 1. It has eight heads.
 - 2. It was discovered in Kerala.
 - 3. It looks like a stem.
 - 4. The spider uses the shape of magical hats to hide.

Question ID : 264330169247

Option 1 ID : 264330663769

Option 2 ID : 264330663770

Option 3 ID : 264330663768

Option 4 ID : 264330663767

Status : Answered

Chosen Option : 4

Comprehension:

Read the given passage and answer the question that follows.

A veteran actor and important link with the golden age of Hindi and Marathi cinema, Sulochana Latkar, passed away in Mumbai at 94 from age-related complications.

Hailing from Kolhapur, Sulochana made a name for herself as a leading heroine in Marathi films before moving to Bombay cinema where she essayed various shades of motherly roles in Hindi cinema for almost four decades.

Sulochana started her career with Bhalji Pendharkar's Sasurvas (1946). A young Sulochana joined his famous Jaiprabha Studios on a monthly salary and learned the intricacies of the craft under the watch of the legendary Marathi filmmaker.

Along with Nirupa Roy, Sulochana will be remembered for epitomising a selfless mother and devoted spouse, which became central to Hindi film narratives in the 1960s and 70s.

SubQuestion No : 91

Q.91 What was the reason behind Sulochana Latkar's death?

- Ans
- 1. Cancer
 - 2. Road accident
 - 3. Age-related complications
 - 4. Heart-attack

Question ID : 264330169598

Option 1 ID : 264330665108

Option 2 ID : 264330665109

Option 3 ID : 264330665110

Option 4 ID : 264330665107

Status : Answered

Chosen Option : 3

Comprehension:

Read the given passage and answer the question that follows.

A veteran actor and important link with the golden age of Hindi and Marathi cinema, Sulochana Latkar, passed away in Mumbai at 94 from age-related complications.

Hailing from Kolhapur, Sulochana made a name for herself as a leading heroine in Marathi films before moving to Bombay cinema where she essayed various shades of motherly roles in Hindi cinema for almost four decades.

Sulochana started her career with Bhalji Pendharkar's Sasurvas (1946). A young Sulochana joined his famous Jaiprabha Studios on a monthly salary and learned the intricacies of the craft under the watch of the legendary Marathi filmmaker.

Along with Nirupa Roy, Sulochana will be remembered for epitomising a selfless mother and devoted spouse, which became central to Hindi film narratives in the 1960s and 70s.

SubQuestion No : 92

Q.92 Sulochana Latkar was an important link between:

- Ans
- 1. Hindi and Malayalam cinema
 - 2. Hindi and Bhojpuri cinema
 - 3. Hindi and Marathi cinema
 - 4. Hindi and Telugu cinema

Question ID : 264330169599

Option 1 ID : 264330665114

Option 2 ID : 264330665111

Option 3 ID : 264330665112

Option 4 ID : 264330665113

Status : Answered

Chosen Option : 3

Comprehension:

Read the given passage and answer the question that follows.

A veteran actor and important link with the golden age of Hindi and Marathi cinema, Sulochana Latkar, passed away in Mumbai at 94 from age-related complications.

Hailing from Kolhapur, Sulochana made a name for herself as a leading heroine in Marathi films before moving to Bombay cinema where she essayed various shades of motherly roles in Hindi cinema for almost four decades.

Sulochana started her career with Bhalji Pendharkar's Sasurvas (1946). A young Sulochana joined his famous Jaiprabha Studios on a monthly salary and learned the intricacies of the craft under the watch of the legendary Marathi filmmaker.

Along with Nirupa Roy, Sulochana will be remembered for epitomising a selfless mother and devoted spouse, which became central to Hindi film narratives in the 1960s and 70s.

SubQuestion No : 93

Q.93 Select the correct order of the given facts based on the life of Sulochana Latkar, the central figure of the passage.

P. She moved to Bombay cinema.

Q. She joined the famous Jaiprabha Studios.

R. She acted in Sasurvas.

S. She passed away in Mumbai at 94.

Ans 1. QRPS

2. RQSP

3. PQRS

4. RQPS

Question ID : 264330169602

Option 1 ID : 264330665125

Option 2 ID : 264330665126

Option 3 ID : 264330665124

Option 4 ID : 264330665123

Status : Answered

Chosen Option : 3

Comprehension:

Read the given passage and answer the question that follows.

A veteran actor and important link with the golden age of Hindi and Marathi cinema, Sulochana Latkar, passed away in Mumbai at 94 from age-related complications.

Hailing from Kolhapur, Sulochana made a name for herself as a leading heroine in Marathi films before moving to Bombay cinema where she essayed various shades of motherly roles in Hindi cinema for almost four decades.

Sulochana started her career with Bhalji Pendharkar's Sasurvas (1946). A young Sulochana joined his famous Jaiprabha Studios on a monthly salary and learned the intricacies of the craft under the watch of the legendary Marathi filmmaker.

Along with Nirupa Roy, Sulochana will be remembered for epitomising a selfless mother and devoted spouse, which became central to Hindi film narratives in the 1960s and 70s.

SubQuestion No : 94

Q.94 Sulochana learned the intricacies of the craft under the guidance of:

Ans 1. Badal Sirkar

2. Bhalji Pendharkar

3. Mahesh Dattani

4. Vijay Tendulkar

Question ID : 264330169600

Option 1 ID : 264330665118

Option 2 ID : 264330665117

Option 3 ID : 264330665115

Option 4 ID : 264330665116

Status : Answered

Chosen Option : 2

Comprehension:

Read the given passage and answer the question that follows.

A veteran actor and important link with the golden age of Hindi and Marathi cinema, Sulochana Latkar, passed away in Mumbai at 94 from age-related complications.

Hailing from Kolhapur, Sulochana made a name for herself as a leading heroine in Marathi films before moving to Bombay cinema where she essayed various shades of motherly roles in Hindi cinema for almost four decades.

Sulochana started her career with Bhalji Pendharkar's Sasurvas (1946). A young Sulochana joined his famous Jaiprabha Studios on a monthly salary and learned the intricacies of the craft under the watch of the legendary Marathi filmmaker.

Along with Nirupa Roy, Sulochana will be remembered for epitomising a selfless mother and devoted spouse, which became central to Hindi film narratives in the 1960s and 70s.

SubQuestion No : 95

Q.95 Which of the following is an INCORRECT fact with reference to the given passage?

- Ans
- 1. She passed away at 94.
 - 2. She was a contemporary of Nirupa Roy.
 - 3. Her native place was Gurdaspur.
 - 4. Sulochana Latkar played a motherly role in most of her films.

Question ID : 264330169601

Option 1 ID : 264330665122

Option 2 ID : 264330665121

Option 3 ID : 264330665120

Option 4 ID : 264330665119

Status : Answered

Chosen Option : 2

Comprehension:

Read the given passage and answer the questions that follow.

In recent years, technology has revolutionised various aspects of our lives, including communication, education, and entertainment. With the rise of smartphones and social media platforms, people can now connect and interact with each other more easily than ever before. Online learning platforms have also gained popularity, allowing individuals to acquire new skills and knowledge from the comfort of their homes. Additionally, streaming services have transformed the way we consume media, providing a vast array of movies, TV shows, and music accessible at our fingertips. While technology has undoubtedly brought numerous benefits, it is essential to strike a balance and ensure that we maintain real-life connections and limit excessive screen time for a healthy and well-rounded lifestyle.

SubQuestion No : 96

Q.96 What does the term 'vast array' mean in the context of the passage?

- Ans
- 1. A small collection
 - 2. A limited assortment
 - 3. A wide variety
 - 4. A narrow selection

Question ID : 264330168240

Option 1 ID : 264330659831

Option 2 ID : 264330659832

Option 3 ID : 264330659833

Option 4 ID : 264330659834

Status : Answered

Chosen Option : 3

Comprehension:

Read the given passage and answer the questions that follow.

In recent years, technology has revolutionised various aspects of our lives, including communication, education, and entertainment. With the rise of smartphones and social media platforms, people can now connect and interact with each other more easily than ever before. Online learning platforms have also gained popularity, allowing individuals to acquire new skills and knowledge from the comfort of their homes. Additionally, streaming services have transformed the way we consume media, providing a vast array of movies, TV shows, and music accessible at our fingertips. While technology has undoubtedly brought numerous benefits, it is essential to strike a balance and ensure that we maintain real-life connections and limit excessive screen time for a healthy and well-rounded lifestyle.

SubQuestion No : 97

Q.97 What has technology revolutionised in recent years?

- Ans
- 1. Transportation
 - 2. Communication, education, and entertainment
 - 3. Fashion industry
 - 4. Agriculture

Question ID : 264330168236

Option 1 ID : 264330659815

Option 2 ID : 264330659817

Option 3 ID : 264330659816

Option 4 ID : 264330659818

Status : Answered

Chosen Option : 2

Comprehension:

Read the given passage and answer the questions that follow.

In recent years, technology has revolutionised various aspects of our lives, including communication, education, and entertainment. With the rise of smartphones and social media platforms, people can now connect and interact with each other more easily than ever before. Online learning platforms have also gained popularity, allowing individuals to acquire new skills and knowledge from the comfort of their homes. Additionally, streaming services have transformed the way we consume media, providing a vast array of movies, TV shows, and music accessible at our fingertips. While technology has undoubtedly brought numerous benefits, it is essential to strike a balance and ensure that we maintain real-life connections and limit excessive screen time for a healthy and well-rounded lifestyle.

SubQuestion No : 98

Q.98 What is one advantage of online learning platforms?

- Ans
- 1. They provide opportunities to learn from home.
 - 2. They limit individuals' ability to acquire new skills and knowledge.
 - 3. They require physical attendance at a specific location.
 - 4. They are only accessible to a select few.

Question ID : 264330168238

Option 1 ID : 264330659825

Option 2 ID : 264330659824

Option 3 ID : 264330659823

Option 4 ID : 264330659826

Status : Answered

Chosen Option : 1

Comprehension:

Read the given passage and answer the questions that follow.

In recent years, technology has revolutionised various aspects of our lives, including communication, education, and entertainment. With the rise of smartphones and social media platforms, people can now connect and interact with each other more easily than ever before. Online learning platforms have also gained popularity, allowing individuals to acquire new skills and knowledge from the comfort of their homes. Additionally, streaming services have transformed the way we consume media, providing a vast array of movies, TV shows, and music accessible at our fingertips. While technology has undoubtedly brought numerous benefits, it is essential to strike a balance and ensure that we maintain real-life connections and limit excessive screen time for a healthy and well-rounded lifestyle.

SubQuestion No : 99**Q.99 How have smartphones and social media platforms impacted people's lives?**

- Ans 1. They have made people more connected and interactive.
2. They have made communication more challenging.
3. They have made people less dependent on technology.
4. They have made people more isolated.

Question ID : 264330168237

Option 1 ID : 264330659821

Option 2 ID : 264330659820

Option 3 ID : 264330659822

Option 4 ID : 264330659819

Status : Not Answered

Chosen Option : --

Comprehension:

Read the given passage and answer the questions that follow.

In recent years, technology has revolutionised various aspects of our lives, including communication, education, and entertainment. With the rise of smartphones and social media platforms, people can now connect and interact with each other more easily than ever before. Online learning platforms have also gained popularity, allowing individuals to acquire new skills and knowledge from the comfort of their homes. Additionally, streaming services have transformed the way we consume media, providing a vast array of movies, TV shows, and music accessible at our fingertips. While technology has undoubtedly brought numerous benefits, it is essential to strike a balance and ensure that we maintain real-life connections and limit excessive screen time for a healthy and well-rounded lifestyle.

SubQuestion No : 100**Q.100 What does the term 'revolutionised' mean in the context of the passage?**

- Ans 1. Caused a physical upheaval
2. Disrupted completely
3. Disassembled and reassembled
4. Transformed dramatically

Question ID : 264330168239

Option 1 ID : 264330659827

Option 2 ID : 264330659829

Option 3 ID : 264330659830

Option 4 ID : 264330659828

Status : Not Answered

Chosen Option : --

Stenographer Grade C and D Examination 2023

Roll Number	
Candidate Name	
Venue Name	UNZIP TECHNOLOGY LLP.
Exam Date	12/10/2023
Exam Time	4:30 PM - 6:30 PM
Subject	Stenographer Grade C and D Examination 2023

Section : General Intelligence and Reasoning

Q.1 A, B, C, D, E, F और G की लंबाई भिन्न-भिन्न है। A केवल तीन लोगों से छोटा है। D केवल F से लंबा है। B, A से लंबा है, लेकिन C और E दोनों से छोटा है। E सबसे लंबा व्यक्ति नहीं है। कितने व्यक्ति G से छोटे हैं?

- Ans 1. दो
 2. चार
 3. तीन
 4. पाँच

Question ID : 264330131657

Option 1 ID : 264330515730

Option 2 ID : 264330515727

Option 3 ID : 264330515728

Option 4 ID : 264330515729

Status : Answered

Chosen Option : 1

Prepare 50% Faster

Q.2 निम्नांकित श्रृंखला में पैटर्न को जारी रखने के लिए प्रश्नचिह्न (?) को किस आकृति द्वारा प्रतिस्थापित किया जाना चाहिए?

L	T	U	3	6	L	6	L	T	=	U	6	
=				T			□			L		?
3	6	□	□	=	U	=	U	4	4	□	T	

Ans

✗ 1.

F	=	U
		6
L	4	□

✓ 2.

U	6	L
		4
□	T	F

✗ 3.

T	6	U
		=
□	4	L

✗ 4.

T	□	4
		=
L	U	=

Question ID : 264330129606

Option 1 ID : 264330507791

Option 2 ID : 264330507790

Option 3 ID : 264330507792

Option 4 ID : 264330507793

Status : Answered

Chosen Option : 1

Q.3 निम्नलिखित में से कौन-सी संख्या दी गई श्रृंखला में प्रश्न चिह्न (?) को प्रतिस्थापित करेगी?
48, 200, 540, ?, 2240

Ans ✗ 1. 1348

✓ 2. 1176

✗ 3. 1248

✗ 4. 1156

Question ID : 26433082430

Option 1 ID : 264330323554

Option 2 ID : 264330323553

Option 3 ID : 264330323556

Option 4 ID : 264330323555

Status : Not Answered

Chosen Option : --

Q.4 यदि '+' का अर्थ '-', '-' का अर्थ '+', 'x' का अर्थ '-' और '-' का अर्थ 'x' है, तो निम्नलिखित समीकरण में प्रश्न चिह्न (?) के स्थान पर क्या आएगा?

$$320 + 64 - 18 \div 2 \times 28 = ?$$

- Ans
- 1. 18
 - 2. 22
 - 3. 13
 - 4. 29

Question ID : 264330101103

Option 1 ID : 264330396958

Option 2 ID : 264330396959

Option 3 ID : 264330396957

Option 4 ID : 264330396960

Status : Answered

Chosen Option : 3

Q.5 उस विकल्प का चयन करें जो तीसरे शब्द से उसी प्रकार संबंधित है जिस प्रकार दूसरा शब्द पहले शब्द से संबंधित है। (शब्दों को अर्थपूर्ण अंग्रेजी/हिन्दी शब्दों के रूप में माना जाना चाहिए और इन्हें शब्द में अक्षरों की संख्या/व्यंजनों की संख्या/स्वरों की संख्या के आधार पर एक-दूसरे से संबद्ध नहीं किया जाना चाहिए।)

क्रिकेट : बैट :: टेनिस : ?

- Ans
- 1. भाला
 - 2. रैकेट
 - 3. नेट
 - 4. पोल

Question ID : 26433087286

Option 1 ID : 264330342783

Option 2 ID : 264330342782

Option 3 ID : 264330342781

Option 4 ID : 264330342784

Status : Answered

Chosen Option : 2

Prepare 50% Faster

Q.6 निम्नांकित श्रृंखला में पैटर्न को जारी रखने के लिए प्रश्नचिह्न (?) को किस आकृति द्वारा प्रतिस्थापित किया जाना चाहिए?

P	P	L	L	
A	3	3	O	?
O L 3	A O L	P A O	3 P A	

Ans

✗ 1.

A		
L		
O	3	P

✓ 2.

A		
O		
L	3	P

✗ 3.

O		
A		
L	3	P

✗ 4.

L		
A		
O	3	P

Question ID : 264330129593

Option 1 ID : 264330507739

Option 2 ID : 264330507740

Option 3 ID : 264330507741

Option 4 ID : 264330507738

Status : Answered

Chosen Option : 2

Q.7 दी गई आकृति में कितने त्रिभुज हैं?

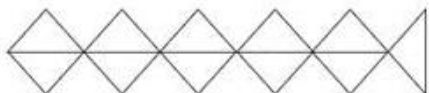

Ans ✓ 1. 11

✗ 2. 12

✗ 3. 9

✗ 4. 10

Question ID : 26433068629

Option 1 ID : 264330269028

Option 2 ID : 264330269029

Option 3 ID : 264330269030

Option 4 ID : 264330269031

Status : Answered

Chosen Option : 1

Q.8 एक निश्चित कूट भाषा में, 'COFFEE' को 'FTKKJH' के रूप में लिखा जाता है और 'EXPERT' को 'HCUJWW' के रूप में लिखा जाता है। उसी भाषा में 'FRENCH' को कैसे लिखा जाएगा?

Ans 1. TWJMGL

2. IWJSHK

3. JXWTHL

4. TWWSHK

Question ID : 26433082560

Option 1 ID : 264330324074

Option 2 ID : 264330324075

Option 3 ID : 264330324076

Option 4 ID : 264330324073

Status : Answered

Chosen Option : 2

Q.9 उस समुच्चय का चयन करें जिसमें दी गई संख्याएं आपस में उसी प्रकार संबंधित हैं, जिस प्रकार प्रश्न में दिए गए समुच्चय की संख्याएं आपस में संबंधित हैं।
(नोट: संख्याओं को उसके घटक अंकों में विभाजित किए बिना, पूर्ण संख्याओं पर ही गणितीय संक्रियाएँ की जानी चाहिए। जैसे 13 - मान लीजिए 13 पर गणितीय संक्रियाएँ जैसे कि 13 में जोड़ना/घटाना/गुणा करना आदि किया जा सकता है। 13 को 1 और 3 में तोड़कर और फिर 1 और 3 पर गणितीय संक्रियाएँ करने की अनुमति नहीं है।)

(2, 35, 5)

(6, 50, 4)

Ans 1. (3, 100, 7)

2. (4, 45, 5)

3. (9, 60, 4)

4. (3, 35, 5)

Question ID : 26433087038

Option 1 ID : 264330341793

Option 2 ID : 264330341794

Option 3 ID : 264330341796

Option 4 ID : 264330341795

Status : Answered

Chosen Option : 2

Q.10 यदि 12 जनवरी 2015 को सोमवार था, तो 26 जनवरी 2016 को सप्ताह का कौन-सा दिन था?

Ans 1. मंगलवार

2. गुरुवार

3. बुधवार

4. शुक्रवार

Question ID : 264330144943

Option 1 ID : 264330568027

Option 2 ID : 264330568029

Option 3 ID : 264330568028

Option 4 ID : 264330568030

Status : Answered

Chosen Option : 1

Q.11 दिए गए विकल्पों में से उस संख्या का चयन कीजिए जो निम्नलिखित श्रृंखला में प्रश्न चिह्न (?) के स्थान पर आ सकती है।
11, 12, 14, 17, ?

- Ans
- 1. 20
 - 2. 22
 - 3. 23
 - 4. 21

Question ID : 264330112661
Option 1 ID : 264330442729
Option 2 ID : 264330442731
Option 3 ID : 264330442732
Option 4 ID : 264330442730
Status : Answered
Chosen Option : 4

Q.12 नीचे एक कथन दिया गया है जिसके बाद दो निष्कर्ष I और II दिए गए हैं। कथन का ध्यानपूर्वक अध्ययन करें और निर्धारित करें कि कौन सा/से निष्कर्ष निश्चित रूप से सत्य है/हैं।
कथन: $M \geq N = O \geq P \leq W$; $X \leq O > Y$
निष्कर्ष I: $M > Y$
निष्कर्ष II: $X \leq W$

- Ans
- 1. केवल निष्कर्ष II सत्य है।
 - 2. न तो निष्कर्ष I सत्य है और न ही II सत्य है।
 - 3. निष्कर्ष I और II दोनों सत्य हैं।
 - 4. केवल निष्कर्ष I सत्य है।

Question ID : 264330131076
Option 1 ID : 264330513416
Option 2 ID : 264330513418
Option 3 ID : 264330513417
Option 4 ID : 264330513415
Status : Answered
Chosen Option : 4

Q.13 श्रुति अपने घर से निकलती है और 47 m पश्चिम की ओर चलती है। फिर वह दाएँ मुड़ती है और 18 m चलती है। वह बाएँ मुड़ती है और 53 m चलती है। अंत में वह बाएँ मुड़ती है और 30 m चलती है। वह उस खंभे से कितनी दूर है, जो उसके घर से ठीक 12 m दक्षिण में है? (मान लीजिए कि सभी मोड़ केवल 90° वाले मोड़ हैं।)

- Ans
- 1. 110 m
 - 2. 105 m
 - 3. 90 m
 - 4. 100 m

Question ID : 264330131619
Option 1 ID : 264330515577
Option 2 ID : 264330515578
Option 3 ID : 264330515575
Option 4 ID : 264330515576
Status : Answered
Chosen Option : 4

Q.14 निम्नलिखित में से कौन-सा पद दी गई श्रृंखला में प्रश्न-चिह्न (?) को प्रतिस्थापित करेगा?
BDH, CEI, DFJ, EGK, FHL, ?

- Ans
- 1. GKM
 - 2. GHM
 - 3. GIM
 - 4. GHJ

Question ID : 26433090155
Option 1 ID : 264330354100
Option 2 ID : 264330354098
Option 3 ID : 264330354099
Option 4 ID : 264330354097
Status : Answered
Chosen Option : 3

Q.15 नीचे तीन कथन और उसके बाद I, II और III संख्यांकित वाले तीन निष्कर्ष दिये गए हैं। यह मानते हुए कि कथनों में दी गई जानकारी सत्य है, भले ही ये कथन सामान्य रूप से ज्ञात तथ्यों से भिन्न प्रतीत होते हों, यह निर्णय कीजिए कि कौन सा/से निष्कर्ष इन कथनों का तार्किक रूप से अनुसरण करता है/करते हैं।

कथन:

- सभी घड़ियां कैमरे हैं।
- कोई कैमरा पेन नहीं है।
- कुछ घड़ियां गेंद हैं।

निष्कर्ष:

- I. कुछ गेंद कैमरे हैं।
- II. कोई गेंद पेन नहीं है।
- III. कोई पेन घड़ी नहीं है।

- Ans
- 1. निष्कर्ष I और II दोनों अनुसरण करते हैं।
 - 2. केवल निष्कर्ष II अनुसरण करता है।
 - 3. केवल निष्कर्ष I अनुसरण करता है।
 - 4. निष्कर्ष I और III दोनों अनुसरण करते हैं।

Question ID : 264330144912
Option 1 ID : 264330567903
Option 2 ID : 264330567905
Option 3 ID : 264330567906
Option 4 ID : 264330567904
Status : Answered
Chosen Option : 4

Q.16 दो कथनों के बाद दो निष्कर्ष I और II दिए गए हैं। कथनों को सत्य मानते हुए, भले ही वे सामान्य रूप से ज्ञात तथ्यों से भिन्न प्रतीत होते हों, निर्णय लीजिए कि कौन सा/से निष्कर्ष कथनों का तार्किक रूप से अनुसरण करता/करते है/हैं।

कथन:

कुछ पर्दे, पंखे हैं।

कुछ पंखे, बल्ब हैं।

निष्कर्ष:

I. कुछ पर्दे, बल्ब हैं।

II. सभी बल्ब, पंखे हैं।

- Ans
- 1. निष्कर्ष I और II दोनों अनुसरण करते हैं
 - 2. केवल निष्कर्ष II अनुसरण करता है
 - 3. न तो निष्कर्ष I अनुसरण करता है और न ही II अनुसरण करता है
 - 4. केवल निष्कर्ष I अनुसरण करता है

Question ID : 264330144959

Option 1 ID : 264330568093

Option 2 ID : 264330568092

Option 3 ID : 264330568094

Option 4 ID : 264330568091

Status : Answered

Chosen Option : 3

Q.17 दो कथन दिए गए हैं, जिसके बाद दो निष्कर्ष I और II दिए गए हैं। कथनों को सत्य मानते हुए, भले ही वे सामान्य रूप से ज्ञात तथ्यों से भिन्न प्रतीत होते हों, निर्णय लें कि कौन-सा/से निष्कर्ष कथनों का तार्किक रूप से अनुसरण करता है/करते हैं।

कथन:

कुछ पियानो गिटार हैं।

सभी गिटार बांसुरी हैं।

निष्कर्ष:

I) कुछ पियानो बांसुरी हैं।

II) कोई गिटार पियानो नहीं है।

- Ans
- 1. केवल निष्कर्ष I अनुसरण करता है।
 - 2. केवल निष्कर्ष II अनुसरण करता है।
 - 3. न तो निष्कर्ष I अनुसरण करता है और न ही II अनुसरण करता है।
 - 4. निष्कर्ष I और II दोनों अनुसरण करते हैं।

Question ID : 26433067709

Option 1 ID : 264330265348

Option 2 ID : 264330265349

Option 3 ID : 264330265351

Option 4 ID : 264330265350

Status : Answered

Chosen Option : 1

Q.18 मेहर अपने घर से पूर्व की ओर 19 km दूरी इकट्ठा करता है। फिर वह बाएं मुड़ता है और 11 km दूरी करता है। वह फिर से बाएं मुड़ता है और 19 km दूरी इकट्ठा करता है। वह एक सीधी रेखा में आरंभिक बिंदु से कितनी दूर है?

- Ans 1. 11 km
 2. 30 km
 3. 21 km
 4. 19 km

Question ID : 264330132110
 Option 1 ID : 264330517538
 Option 2 ID : 264330517536
 Option 3 ID : 264330517535
 Option 4 ID : 264330517537
 Status : Answered
 Chosen Option : 1

Q.19 दिए गए समीकरण को संतुलित करने के लिए किन दो संख्याओं (अंकों को नहीं) को परस्पर बदलना होगा?

$$(\sqrt{144} \div 4)^3 + (6)^2 - (28 \times 2) + 72 + (32 \div 8) \times 3 = 52$$

- Ans 1. 4 और 6
 2. 2 और 4
 3. 3 और 6
 4. 2 और 8

Question ID : 264330144856
 Option 1 ID : 264330567681
 Option 2 ID : 264330567682
 Option 3 ID : 264330567680
 Option 4 ID : 264330567679
 Status : Answered
 Chosen Option : 1

Q.20 यदि 'A' का अर्थ '+' है, 'B' का अर्थ 'x' है, 'C' का अर्थ '÷' है और 'D' का अर्थ '-' है, तो निम्नलिखित समीकरण में प्रश्न चिह्न (?) के स्थान पर क्या आएगा?
 62 B 2 D 45 A 5 C 7 = ?

- Ans 1. 121
 2. 123
 3. 120
 4. 122

Question ID : 264330141903
 Option 1 ID : 26433055932
 Option 2 ID : 26433055934
 Option 3 ID : 26433055931
 Option 4 ID : 26433055933
 Status : Answered
 Chosen Option : 4

Q.21 निम्नलिखित में से कौन-सी संख्या, दी गई श्रृंखला में प्रश्नचिह्न (?) को प्रतिस्थापित करेगी?
414, 410, 402, 390, 374, ?

Ans ✓ 1. 354

✗ 2. 367

✗ 3. 366

✗ 4. 309

Question ID : 264330102158

Option 1 ID : 264330401099

Option 2 ID : 264330401097

Option 3 ID : 264330401100

Option 4 ID : 264330401098

Status : Answered

Chosen Option : 1



Prepare 50% Faster

Q.22 उस विकल्प का चयन करें जिसमें दी गई आकृति अंतर्निहित है (घुमाने की अनुमति नहीं है)।



Ans

✗ 1.

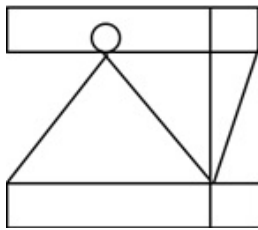

✓ 2.

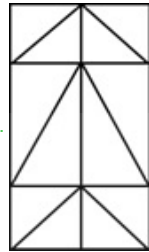

✗ 3.

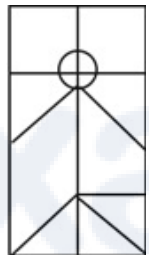

✗ 4.



Question ID : 264330111654

Option 1 ID : 264330438704

Option 2 ID : 264330438701

Option 3 ID : 264330438702

Option 4 ID : 264330438703

Status : Answered

Chosen Option : 2

Q.23 छह विद्यार्थी एक वृत्ताकार मेज के परितः केंद्र की ओर मुख करके बैठे हैं। अमित, जिया के बायें दूसरे स्थान पर बैठा है। जिया, वरुण और प्रमोद दोनों की निकटतम पड़ोसी है। सिया, अमित के बायें दूसरे स्थान पर बैठी है। अमित, महेश और वरुण दोनों का निकटतम पड़ोसी है। सिया और जिया का निकटतम पड़ोसी कौन है?

- Ans
- ✓ 1. प्रमोद
 - ✗ 2. महेश
 - ✗ 3. अमित
 - ✗ 4. वरुण

Question ID : 26433055680
 Option 1 ID : 264330217704
 Option 2 ID : 264330217707
 Option 3 ID : 264330217706
 Option 4 ID : 264330217705
 Status : Answered
 Chosen Option : 1

Q.24 उस समुच्चय का चयन कीजिए, जिसमें संख्याएँ उसी तरह से संबंधित हैं, जिस प्रकार दिए गए समुच्चय की संख्याएँ आपस में संबंधित हैं। (नोट: संख्याओं को उसके घटक अंकों में विभाजित किए बिना, पूर्ण संख्याओं पर ही गणितीय संक्रियाएँ की जानी चाहिए। जैसे 13 - मान लीजिए 13 पर गणितीय संक्रियाएँ जैसे कि 13 में जोड़ना/घटाना/गुणा करना आदि किया जा सकता है। 13 को 1 और 3 में तोड़कर और फिर 1 और 3 पर गणितीय संक्रियाएँ करने की अनुमति नहीं है।)
 (7, 17, 35)
 (5, 11, 23)

- Ans
- ✗ 1. (10, 26, 54)
 - ✓ 2. (9, 23, 47)
 - ✗ 3. (11, 29, 58)
 - ✗ 4. (8, 20, 39)

Question ID : 26433078962
 Option 1 ID : 264330309862
 Option 2 ID : 264330309861
 Option 3 ID : 264330309860
 Option 4 ID : 264330309863
 Status : Answered
 Chosen Option : 2

Q.25 निम्नलिखित चार अक्षर-समूहों में से तीन किसी निश्चित तरीके से आपस में संगत हैं जबकि कोई एक उनसे असंगत है। असंगत अक्षर-समूह का चयन कीजिए।

- Ans
- ✗ 1. RUF
 - ✓ 2. GTQ
 - ✗ 3. ADW
 - ✗ 4. KNM

Question ID : 26433058004
 Option 1 ID : 264330227003
 Option 2 ID : 264330227000
 Option 3 ID : 264330227001
 Option 4 ID : 264330227002
 Status : Answered
 Chosen Option : 2

Q.26 उस विकल्प का चयन करें, जो छठी संख्या से उसी प्रकार संबंधित है, जिस प्रकार पहली संख्या दूसरी संख्या से और तीसरी संख्या चौथी संख्या से संबंधित है।
133 : 7 :: 247 : 13 :: ? : 19

- Ans 1. 361
 2. 399
 3. 242
 4. 266

Question ID : 26433087209
Option 1 ID : 264330342475
Option 2 ID : 264330342476
Option 3 ID : 264330342474
Option 4 ID : 264330342473
Status : Answered
Chosen Option : 1

Q.27 दी गई श्रृंखला को पूरा करने के लिए कौन-सा अक्षर-समूह प्रश्नवाचक चिह्न (?) को प्रतिस्थापित करेगा?

DTXO, FSVN, JRRM, ?, XPKD

- Ans 1. QLPK
 2. PQLL
 3. QPKL
 4. POLK

Question ID : 264330144906
Option 1 ID : 264330567879
Option 2 ID : 264330567882
Option 3 ID : 264330567881
Option 4 ID : 264330567880
Status : Answered
Chosen Option : 2

Q.28 दिए गए विकल्पों में से उस संख्या का चयन कीजिए जो निम्नलिखित श्रृंखला में प्रश्न चिह्न (?) के स्थान पर आ सकती है।
43, 47, 55, 67, ?

- Ans 1. 85
 2. 87
 3. 81
 4. 83

Question ID : 264330112672
Option 1 ID : 264330442775
Option 2 ID : 264330442776
Option 3 ID : 264330442773
Option 4 ID : 264330442774
Status : Answered
Chosen Option : 4

Q.29 'P + Q' का अर्थ है 'P, Q की पत्नी है'
'P - Q' का अर्थ है 'P, Q की पुत्री है'
'P × Q' का अर्थ है 'P, Q का पिता है'
'P ÷ Q' का अर्थ है 'P, Q का भाई है'
यदि 'V + M ÷ R - K' है, तो R, V से किस प्रकार संबंधित है?

- Ans
- 1. बहन
 - 2. सास
 - 3. ननद
 - 4. भाई

Question ID : 264330102471

Option 1 ID : 264330402315

Option 2 ID : 264330402316

Option 3 ID : 264330402314

Option 4 ID : 264330402313

Status : Answered

Chosen Option : 3

Q.30 उस विकल्प का चयन कीजिए जो नीचे दिए गए शब्दों के उस सही क्रम को दर्शाता है, जिस क्रम में वे अंग्रेजी शब्दकोश में आएंगे।

1. Melodrama
2. Melodious
3. Melancholy
4. Melting
5. Melanin
6. Mellowed

- Ans
- 1. 3, 5, 6, 2, 1, 4
 - 2. 4, 3, 5, 6, 2, 1
 - 3. 3, 5, 6, 1, 2, 4
 - 4. 3, 5, 1, 2, 6, 4

Question ID : 264330144928

Option 1 ID : 264330567970

Option 2 ID : 264330567968

Option 3 ID : 264330567969

Option 4 ID : 264330567967

Status : Answered

Chosen Option : 1

Q.31 दिए गए विकल्पों में से उस आकृति का चयन करें, जो निम्नलिखित शृंखला में प्रश्नचिह्न (?) को प्रतिस्थापित करेगी।

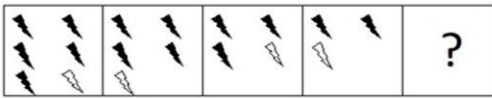

Ans

✗ 1.



✗ 2.



✗ 3.



✓ 4.



Question ID : 26433087164

Option 1 ID : 264330342293

Option 2 ID : 264330342296

Option 3 ID : 264330342294

Option 4 ID : 264330342295

Status : Answered

Chosen Option : 4

Q.32 निम्नलिखित में से कौन-सी संख्याओं को (अंकों को नहीं) आपस में प्रतिस्थापित करने पर दिया गया समीकरण संतुलित हो जाएगा?

$$30 \times 6 \div 15 + 7 + 40 = 50$$

Ans ✗ 1. 6, 30

✗ 2. 40, 50

✗ 3. 15, 40

✓ 4. 15, 30

Question ID : 264330144864

Option 1 ID : 264330567711

Option 2 ID : 264330567714

Option 3 ID : 264330567713

Option 4 ID : 264330567712

Status : Answered

Chosen Option : 4

Q.33 उस विकल्प आकृति का चयन करें, जिसमें दी गई आकृति सन्निकित है (घुमाने की अनुमति नहीं है)।



Ans

✗ 1.

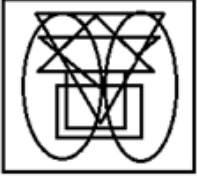

✓ 2.

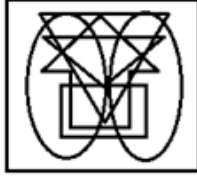

✗ 3.

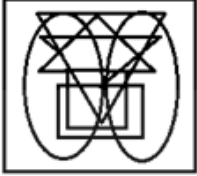

✗ 4.

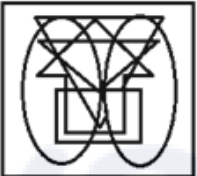

Question ID : 264330129590

Option 1 ID : 264330507728

Option 2 ID : 264330507726

Option 3 ID : 264330507727

Option 4 ID : 264330507729

Status : Answered

Chosen Option : 2

Q.34 M, R की पुत्री है। Z, M का पति है। X, R का पुत्र है। Z, Y का दामाद है। X, Y से किस प्रकार संबंधित है?

Ans ✗ 1. भाई

✗ 2. दामाद

✓ 3. पुत्र

✗ 4. ताऊ/चाचा

Question ID : 26433099144

Option 1 ID : 264330389190

Option 2 ID : 264330389189

Option 3 ID : 264330389191

Option 4 ID : 264330389192

Status : Answered

Chosen Option : 3

Q.35 निम्नलिखित चार अक्षर-समूहों में से तीन किसी निश्चित तरीके से आपस में संगत हैं जबकि कोई एक उनसे असंगत है। असंगत अक्षर-समूह का चयन कीजिए।

Ans 1. FUW

2. NMP

3. BYA

4. KPR

Question ID : 26433057222

Option 1 ID : 264330223873

Option 2 ID : 264330223874

Option 3 ID : 264330223872

Option 4 ID : 264330223875

Status : Answered

Chosen Option : 2

Q.36 निम्नलिखित शब्दों को तार्किक और अर्थपूर्ण क्रम में दर्शाने वाले सही विकल्प का चयन करें।

1. फर्नीचर

2. अलमारी

3. हैंडल

4. दराज

5. लकड़ी

Ans 1. 1, 3, 4, 2, 5

2. 3, 4, 2, 5, 1

3. 4, 3, 1, 2, 5

4. 3, 4, 2, 1, 5

Question ID : 264330132912

Option 1 ID : 264330520710

Option 2 ID : 264330520708

Option 3 ID : 264330520707

Option 4 ID : 264330520709

Status : Answered

Chosen Option : 4

Q.37 उस विकल्प का चयन कीजिए जो पाँचवीं संख्या से उसी प्रकार संबंधित हो, जैसे दूसरी संख्या पहली संख्या से संबंधित है और चौथी संख्या तीसरी संख्या से संबंधित है।
15 : 145 :: 10 : 95 :: 20 : ?

Ans 1. 195

2. 200

3. 205

4. 190

Question ID : 26433089553

Option 1 ID : 264330351714

Option 2 ID : 264330351715

Option 3 ID : 264330351716

Option 4 ID : 264330351713

Status : Answered

Chosen Option : 1

Q.38 एक निश्चित कूट भाषा में, 'CREATE' को 'DTHEYK' के रूप में लिखा जाता है, 'CRITICAL' को 'DTLXNIHT' के रूप में लिखा जाता है, उसी भाषा में 'SKILL' को कैसे लिखा जाएगा?

- Ans
- 1. SMLQQ
 - 2. TNO PQ
 - 3. RMLPR
 - 4. TMLPQ

Question ID : 26433079394
 Option 1 ID : 264330311567
 Option 2 ID : 264330311566
 Option 3 ID : 264330311565
 Option 4 ID : 264330311564
 Status : Answered
 Chosen Option : 4

Q.39 दिए गए विकल्पों में से उस संख्या का चयन कीजिए जो निम्नलिखित श्रृंखला में प्रश्न चिह्न (?) के स्थान पर आ सकती है।
 23, 34, 45, 56, 67, ?

- Ans
- 1. 77
 - 2. 78
 - 3. 79
 - 4. 76

Question ID : 264330112657
 Option 1 ID : 264330442714
 Option 2 ID : 264330442715
 Option 3 ID : 264330442716
 Option 4 ID : 264330442713
 Status : Answered
 Chosen Option : 2

Q.40 दी गई श्रृंखला को पूरा करने के लिए कौन-सा अक्षर-समूह प्रश्न चिह्न (?) को प्रतिस्थापित करेगा?
 TWGC, PUFZ, ?, HQDT, DOCQ

- Ans
- 1. LSEV
 - 2. LSDW
 - 3. LSEW
 - 4. LSDV

Question ID : 26433067961
 Option 1 ID : 264330266358
 Option 2 ID : 264330266357
 Option 3 ID : 264330266356
 Option 4 ID : 264330266359
 Status : Answered
 Chosen Option : 3

Q.41 यदि 'A' का अर्थ '+' है, 'B' का अर्थ 'x' है, 'C' का अर्थ '-' है और 'D' का अर्थ '-' है, तो निम्नलिखित समीकरण में प्रश्न चिह्न (?) के स्थान पर क्या आएगा?
16 B 5 D 16 A 8 C 10 = ?

- Ans
- 1. 58
 - 2. 68
 - 3. 78
 - 4. 88

Question ID : 264330141902

Option 1 ID : 264330555927

Option 2 ID : 264330555928

Option 3 ID : 264330555929

Option 4 ID : 264330555930

Status : Answered

Chosen Option : 4

Q.42 निम्नलिखित में से उस समुच्चय का चयन कीजिए, जिसमें संख्याएँ उसी प्रकार से संबंधित हैं, जिस प्रकार दिए गए समुच्चय की संख्याएँ संबंधित हैं।

(नोट: संख्याओं को उसके घटक अंकों में विभाजित किए बिना, पूर्ण संख्याओं पर ही गणितीय संक्रियाएँ की जानी चाहिए। जैसे 13 - मान लीजिए 13 पर गणितीय संक्रियाएँ जैसे कि 13 में जोड़ना/घटाना/गुणा करना आदि किया जा सकता है। 13 को 1 और 3 में तोड़कर और फिर 1 और 3 पर गणितीय संक्रियाएँ करने की अनुमति नहीं है।)

(100, 30, 10)
(250, 60, 70)

- Ans
- 1. (700, 220, 40)
 - 2. (310, 198, 30)
 - 3. (209, 122, 109)
 - 4. (240, 187, 104)

Question ID : 26433083126

Option 1 ID : 264330326339

Option 2 ID : 264330326340

Option 3 ID : 264330326337

Option 4 ID : 264330326338

Status : Answered

Chosen Option : 1

Q.43 सात लोग A, B, C, D, E, F और G उत्तर की तरफ मुंह करके एक सीधी पंक्ति में बैठे हुए हैं। E के बाएं केवल 2 लोग बैठे हैं। G, E के ठीक बगल में बैठा है। B, F के दाएं ठीक बगल में बैठा है। G और F के बीच में केवल 3 लोग बैठे हैं। A, D के बाएं ठीक बगल में बैठा है।

E के दाएं ठीक बगल में कौन बैठा है?

- Ans
- 1. A
 - 2. G
 - 3. D
 - 4. F

Question ID : 264330144960

Option 1 ID : 264330568096

Option 2 ID : 264330568095

Option 3 ID : 264330568097

Option 4 ID : 264330568098

Status : Answered

Chosen Option : 1

Q.44 उस विकल्प का चयन करें जो तीसरे शब्द से उसी प्रकार संबंधित है जिस प्रकार दूसरा शब्द पहले शब्द से संबंधित है। (शब्दों को हिंदी के अर्थपूर्ण शब्दों के रूप में माना जाना चाहिए और उन्हें अक्षरों की संख्या/व्यंजनों/स्वरों की संख्या के आधार पर एक-दूसरे से संबंधित नहीं किया जाना चाहिए।)
साँप : फुफकार :: पत्ते : ?

- Ans
- ✗ 1. कलरव
 - ✗ 2. कुड़कुड़ाना
 - ✗ 3. गुंजन
 - ✓ 4. सरसराहट

Question ID : 26433069173
Option 1 ID : 264330271204
Option 2 ID : 264330271205
Option 3 ID : 264330271207
Option 4 ID : 264330271206
Status : Answered
Chosen Option : 4

Q.45 उस विकल्प आकृति का चयन करें, जिसमें दी गई आकृति सन्निकित है (घुमाने की अनुमति नहीं है)।



Ans

✗ 1.

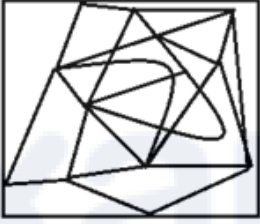

✗ 2.

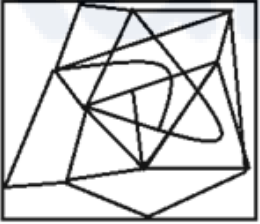

✗ 3.

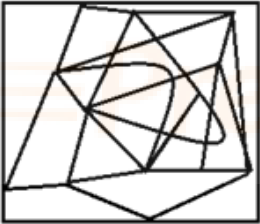

✓ 4.

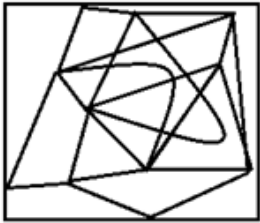

Question ID : 264330129591
Option 1 ID : 264330507730
Option 2 ID : 264330507733
Option 3 ID : 264330507731
Option 4 ID : 264330507732
Status : Answered
Chosen Option : 4

Q.46 गणितीय चिह्नों के उचित संयोजन को चुनिए, जो '%' को क्रमिक रूप से प्रतिस्थापित कर सके और दिए गए समीकरण को संतुलित कर सके।
35 % 4 % 12 % 3 % 6 % 5 % 5

- Ans 1. -, +, +, x, =, +
 2. -, +, x, =, +, +
 3. -, +, +, =, x, +
 4. +, -, +, x, =, +

Question ID : 264330129587

Option 1 ID : 264330507717

Option 2 ID : 264330507714

Option 3 ID : 264330507715

Option 4 ID : 264330507716

Status : Answered

Chosen Option : 3

Q.47 उस विकल्प का चयन करें, जो छठी संख्या से उसी प्रकार संबंधित है, जिस प्रकार पहली संख्या दूसरी संख्या से और तीसरी संख्या चौथी संख्या से संबंधित है।
1444 : 38 :: 1225 : 35 :: ? : 47

- Ans 1. 1369
 2. 1024
 3. 2162
 4. 2209

Question ID : 26433087210

Option 1 ID : 264330342477

Option 2 ID : 264330342478

Option 3 ID : 264330342480

Option 4 ID : 264330342479

Status : Answered

Chosen Option : 4

Prepare 50% Faster

Q.48 एक कागज को नीचे दर्शाए गए अनुसार मोड़ा और काटा जाता है। खोलने के बाद यह कैसा दिखाई देगा?

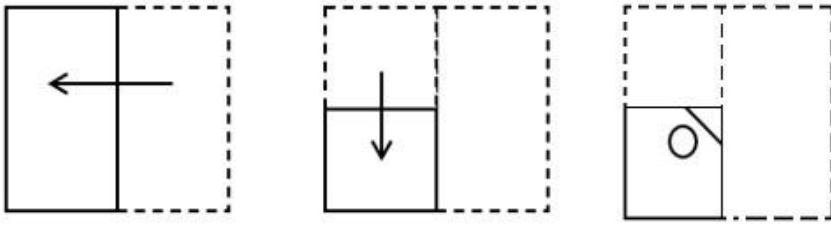

Ans

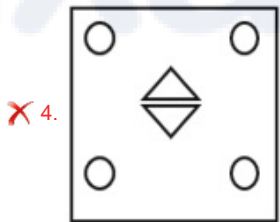
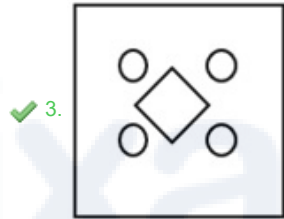
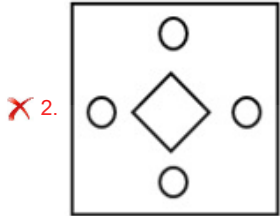
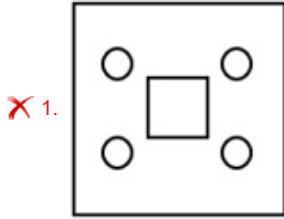

Question ID : 264330106342

Option 1 ID : 264330417670

Option 2 ID : 264330417672

Option 3 ID : 264330417671

Option 4 ID : 264330417669

Status : Answered

Chosen Option : 3

Q.49 तीन कथनों के बाद तीन निष्कर्ष I, II और III दिए गए हैं। कथनों को सत्य मानते हुए, भले ही वे सामान्य रूप से ज्ञात तथ्यों से भिन्न प्रतीत होते हों, निर्धारित करें कि कौन-सा/से निष्कर्ष कथनों का तार्किक रूप से अनुसरण करता है/करते हैं।

कथन:

सभी बार्बी स्नो-व्हाइट हैं।

कुछ बार्बी एरियल हैं।

कुछ एरियल डोरेमोन हैं।

निष्कर्ष:

I. कुछ डोरेमोन स्नो-व्हाइट हैं।

II. कुछ बार्बी डोरेमोन हैं।

III. कुछ एरियल स्नो-व्हाइट हैं।

- Ans
- 1. सभी निष्कर्ष अनुसरण करते हैं।
 - 2. केवल निष्कर्ष I और III अनुसरण करते हैं।
 - 3. केवल निष्कर्ष II और III अनुसरण करते हैं।
 - 4. केवल निष्कर्ष III अनुसरण करता है।

Question ID : 26433085341

Option 1 ID : 264330335068

Option 2 ID : 264330335066

Option 3 ID : 264330335067

Option 4 ID : 264330335065

Status : Answered

Chosen Option : 4

Q.50 उस विकल्प का चयन करें जिसमें दी गई आकृति अंतर्निहित है (घुमाने की अनुमति नहीं है)।

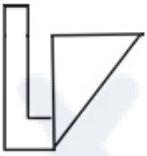

Ans

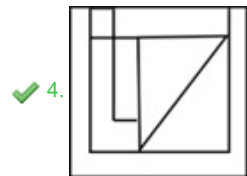
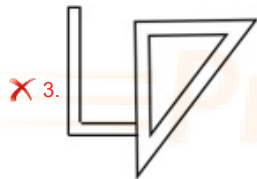
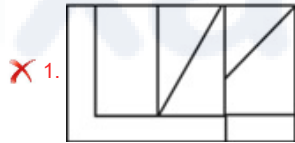

Question ID : 264330111659

Option 1 ID : 264330438724

Option 2 ID : 264330438721

Option 3 ID : 264330438723

Option 4 ID : 264330438722

Status : Answered

Chosen Option : 4

Q.1 कालिदास सम्मान की आवृत्ति क्या है?

- Ans
- 1. दो साल में एक बार
 - 2. तीन साल में एक बार
 - 3. पाँच साल में एक बार
 - 4. साल में एक बार

Question ID : 264330157020

Option 1 ID : 264330615456

Option 2 ID : 264330615457

Option 3 ID : 264330615458

Option 4 ID : 264330615455

Status : Answered

Chosen Option : 4

Q.2 इनमें से कौन 'मैन्स सर्च फॉर मीनिंग' ('Man's Search for Meaning') के/की रचनाकार हैं?

- Ans
- 1. एली वीज़ल
 - 2. विक्टर ई फ्रैंकल
 - 3. अल्फ्रेड लैसिंग
 - 4. एडिथ ईगर

Question ID : 264330144840

Option 1 ID : 264330567616

Option 2 ID : 264330567615

Option 3 ID : 264330567617

Option 4 ID : 264330567618

Status : Not Answered

Chosen Option : --

Q.3 'शहरी स्वरोजगार कार्यक्रम' और 'शहरी मजदूरी रोजगार कार्यक्रम' भारत के किस गरीबी उन्मूलन कार्यक्रम के दो विशेष घटक हैं?

- Ans
- 1. अंत्योदय अन्न योजना
 - 2. ग्रामीण रोजगार सृजन कार्यक्रम
 - 3. स्वर्ण जयंती शहरी रोजगार योजना
 - 4. प्रधानमंत्री ग्रामोदय योजना

Question ID : 264330130599

Option 1 ID : 264330511507

Option 2 ID : 264330511509

Option 3 ID : 264330511510

Option 4 ID : 264330511508

Status : Answered

Chosen Option : 2

Q.4 गुरु गंगाधर प्रधान पुरस्कार कला के किस क्षेत्र में दिया जाता है?

- Ans
- 1. चित्रकारी
 - 2. नृत्य
 - 3. रंगमंच
 - 4. वस्त्र कला

Question ID : 264330130532

Option 1 ID : 264330511240

Option 2 ID : 264330511239

Option 3 ID : 264330511241

Option 4 ID : 264330511242

Status : Answered

Chosen Option : 3

Q.5 उच्च उपाज वाली किस्म के बीजों का संबंध निम्नलिखित में से किस देश से है, जिनका उपयोग हरित क्रांति की नीतियों के तहत भारत में किया गया था?

- Ans
- 1. चीन
 - 2. मेक्सिको
 - 3. संयुक्त राज्य अमेरिका
 - 4. रूस

Question ID : 264330111754
Option 1 ID : 264330439103
Option 2 ID : 264330439102
Option 3 ID : 264330439101
Option 4 ID : 264330439104
Status : Answered
Chosen Option : 4

Q.6 निम्नलिखित में से कौन सा स्थल-युग्म बौद्ध रेलिंग और प्रवेश द्वार के लिए प्रसिद्ध है?

- Ans
- 1. सारनाथ और कुशीनगर
 - 2. पारसनाथ और अजंता
 - 3. पटना और राजगीर
 - 4. भरहुत और अमरावती

Question ID : 264330141801
Option 1 ID : 264330555525
Option 2 ID : 264330555523
Option 3 ID : 264330555526
Option 4 ID : 264330555524
Status : Answered
Chosen Option : 1

Q.7 भारत के प्रथम रक्षा मंत्री कौन थे?

- Ans
- 1. स्वर्ण सिंह
 - 2. कैलाश नाथ काटजू
 - 3. बलदेव सिंह
 - 4. वाई.बी. चव्हाण

Question ID : 264330133076
Option 1 ID : 264330521357
Option 2 ID : 264330521358
Option 3 ID : 264330521356
Option 4 ID : 264330521355
Status : Answered
Chosen Option : 3

Q.8 Which process of phase transition is the reverse of deposition?

- Ans
- 1. Vaporisation
 - 2. Fusion
 - 3. Solidification
 - 4. Sublimation

Question ID : 264330169304
Option 1 ID : 264330663996
Option 2 ID : 264330663995
Option 3 ID : 264330663997
Option 4 ID : 264330663998
Status : Answered
Chosen Option : 3

Q.9 'द लास्ट सॉन्ग ऑफ डस्क' किसका पहला उपन्यास है?

- Ans
- 1. रविंदर सिंह
 - 2. इरा त्रिवेदी
 - 3. सिद्धार्थ धनवंत सांघवी
 - 4. निकिता सिंह

Question ID : 26433071714
Option 1 ID : 264330281283
Option 2 ID : 264330281282
Option 3 ID : 264330281281
Option 4 ID : 264330281280
Status : Not Answered
Chosen Option : --

Q.10 ऊतकीय परीक्षण के लिए कोशिका द्रव्य, लाल रक्त कणिकाओं, कोलेजन और पेशी तंतुओं को अभिरंजित करने के लिए इस्तेमाल किया जाने वाला उत्क्रमणीय, प्रतिदीप्तशील लाल, अम्लीय रंजक निम्नलिखित में से कौन-सा है?

- Ans
- 1. ऐलिजरिन (Alizarin)
 - 2. क्रिस्टल वायलेट (Crystal violet)
 - 3. इओसिन (Eosin)
 - 4. सैफ्रेनिन (Safranin)

Question ID : 264330113470
Option 1 ID : 264330445968
Option 2 ID : 264330445965
Option 3 ID : 264330445966
Option 4 ID : 264330445967
Status : Not Answered
Chosen Option : --

Q.11 'पारो ल्सेचु', _____ में सबसे लोकप्रिय त्योहारों में से एक है।

- Ans
- 1. भूटान
 - 2. चीन
 - 3. मालदीव
 - 4. म्यांमार

Question ID : 264330119833
Option 1 ID : 264330469609
Option 2 ID : 264330469608
Option 3 ID : 264330469607
Option 4 ID : 264330469610
Status : Answered
Chosen Option : 1

Q.12 निम्नलिखित में से कौन 20वीं शताब्दी में शास्त्रीय नृत्य की भरतनाट्यम शैली के प्रमुख प्रतिपादकों में से एक थीं?

- Ans
- 1. कुमुदिनी लखिया
 - 2. निर्मला मेहता
 - 3. टी. बालासरस्वती
 - 4. बिजयिनी सत्यथी

Question ID : 264330157015
Option 1 ID : 264330615435
Option 2 ID : 264330615438
Option 3 ID : 264330615436
Option 4 ID : 264330615437
Status : Answered
Chosen Option : 3

Q.13 कार्बन के अपररूपों के संबंध में असंगत शब्द की पहचान कीजिए।

- Ans
- 1. हीरा
 - 2. बकमिस्टर फुलेरीन
 - 3. ग्रेफाइट
 - 4. टंगस्टन

Question ID : 264330134858
Option 1 ID : 264330528370
Option 2 ID : 264330528368
Option 3 ID : 264330528369
Option 4 ID : 264330528367
Status : Answered
Chosen Option : 4

Q.14 मुलायम सिंह यादव (मरणोपरांत) को वर्ष 2023 के लिए निम्नलिखित में से किस नागरिक पुरस्कार से सम्मानित किया गया?

- Ans
- 1. भारत रत्न
 - 2. पद्म भूषण
 - 3. पद्म विभूषण
 - 4. पद्म श्री

Question ID : 264330133007
Option 1 ID : 264330521083
Option 2 ID : 264330521085
Option 3 ID : 264330521084
Option 4 ID : 264330521086
Status : Answered
Chosen Option : 4

Q.15 क्रिस्टियानो रोनाल्डो का संबंध किस देश से है?

- Ans
- 1. पुर्तगाल
 - 2. जर्मनी
 - 3. ब्राज़ील
 - 4. अर्जेंटीना

Question ID : 264330110357
Option 1 ID : 264330433707
Option 2 ID : 264330433708
Option 3 ID : 264330433705
Option 4 ID : 264330433706
Status : Answered
Chosen Option : 1

Q.16 सोहराई, करम और जावा त्योहार भारत के किस राज्य में मनाए जाते हैं?

- Ans 1. झारखंड
 2. हरियाणा
 3. आंध्र प्रदेश
 4. राजस्थान

Question ID : 264330111160
 Option 1 ID : 264330436727
 Option 2 ID : 264330436726
 Option 3 ID : 264330436725
 Option 4 ID : 264330436728
 Status : Answered
 Chosen Option : 1

Q.17 निम्नलिखित में से कौन-सा अनुच्छेद राज्य को सामाजिक और सांस्कृतिक रूप से पिछड़े वर्गों और अनुसूचित जातियों तथा अनुसूचित जनजातियों के लोगों की कुछ श्रेणियों के उत्थान के लिए प्रावधान करने की अनुमति देता है?

- Ans 1. अनुच्छेद 14
 2. अनुच्छेद 17
 3. अनुच्छेद 15
 4. अनुच्छेद 16

Question ID : 264330112775
 Option 1 ID : 264330443185
 Option 2 ID : 264330443188
 Option 3 ID : 264330443186
 Option 4 ID : 264330443187
 Status : Answered
 Chosen Option : 2

Q.18 तिरुपति तिरुमाला ब्रह्मोत्सवम कितने दिनों के लिए आयोजित किया जाता है?

- Ans 1. 5
 2. 9
 3. 15
 4. 12

Question ID : 26433074094
 Option 1 ID : 264330290496
 Option 2 ID : 264330290497
 Option 3 ID : 264330290499
 Option 4 ID : 264330290498
 Status : Not Answered
 Chosen Option : --

Q.19 प्रथम एशियाई खेल कब और कहाँ आयोजित किए गए थे?

- Ans 1. 1983 में, बांग्लादेश
 2. 1951 में, नई दिल्ली
 3. 1984 में, नेपाल
 4. 1981 में, नई दिल्ली

Question ID : 264330110363
 Option 1 ID : 264330433732
 Option 2 ID : 264330433731
 Option 3 ID : 264330433729
 Option 4 ID : 264330433730
 Status : Answered
 Chosen Option : 2

Q.20 मुगल बादशाह जहांगीर से ईस्ट इंडिया कंपनी के लिए व्यापारिक रियायतें प्राप्त करने में कौन सफल हुआ था?

- Ans
- 1. कैप्टन बेस्ट
 - 2. जॉन मिल्लेनहॉल
 - 3. कैप्टन हॉकिन्स
 - 4. थॉमस रो

Question ID : 264330112187
Option 1 ID : 264330440834
Option 2 ID : 264330440835
Option 3 ID : 264330440833
Option 4 ID : 264330440836
Status : Answered
Chosen Option : 3

Q.21 भारत सरकार अधिनियम, 1935 के अंतर्गत _____ में पहली बार प्रांतीय चुनाव हुए थे।

- Ans
- 1. 1935
 - 2. 1937
 - 3. 1938
 - 4. 1936

Question ID : 264330111395
Option 1 ID : 264330437666
Option 2 ID : 264330437668
Option 3 ID : 264330437667
Option 4 ID : 264330437665
Status : Answered
Chosen Option : 3

Q.22 _____, चलनिधि समायोजन सुविधा (LAF) के तहत आने वाला एक साधन है, जिसपर आरबीआई (RBI) वाणिज्यिक बैंकों को उधार देता है।

- Ans
- 1. रेपो दर
 - 2. आरक्षित नकदी निधि अनुपात
 - 3. बैंक दर
 - 4. रिवर्स रेपो दर

Question ID : 264330109976
Option 1 ID : 264330432182
Option 2 ID : 264330432184
Option 3 ID : 264330432181
Option 4 ID : 264330432183
Status : Answered
Chosen Option : 1

Q.23 सामान्य तौर पर क्रेकर, माइक्रोवेव पॉपकॉर्न, बटर और चिकन नगेट्स जैसे खाद्य पदार्थों में उपयोग किया जाने वाला कौन-सा संलिप्त सुगंधित कार्बनिक यौगिक, ऑक्सीजन की उपस्थिति में होने वाले भोजन के रासायनिक अपघटन को रोकता है?

- Ans 1. तृतीयक ब्यूटाइल हाइड्रो किनोन
 2. डाइएथिलटोल्यूमाइड
 3. 1,4-डाइक्लोरोबेंजीन
 4. सोडियम हाइपोक्लोराइट

Question ID : 264330131009

Option 1 ID : 264330513149

Option 2 ID : 264330513148

Option 3 ID : 264330513147

Option 4 ID : 264330513150

Status : Not Answered

Chosen Option : --

Q.24 वर्ष 2022 में पद्म श्री पुरस्कार से सम्मानित माधुरी बड़थवाल _____ के क्षेत्र में अपने योगदान के लिए प्रसिद्ध हैं।

- Ans 1. कश्मीरी लोक संगीत
 2. पंजाबी लोक संगीत
 3. गढ़वाली लोक संगीत
 4. बुंदेलखंडी लोक संगीत

Question ID : 26433064635

Option 1 ID : 264330253135

Option 2 ID : 264330253132

Option 3 ID : 264330253133

Option 4 ID : 264330253134

Status : Answered

Chosen Option : 3

Q.25 इस्लाम और ईसाई धर्म जैसे अन्य धर्मों में परिवर्तित कर दिये गए हिंदुओं के शुद्धिकरण के लिए 'शुद्धि' आंदोलन निम्नलिखित में से किस संस्था द्वारा चलाया गया था?

- Ans 1. ब्रह्म समाज
 2. आर्य समाज
 3. वेद समाज
 4. रामकृष्ण मिशन

Question ID : 264330165403

Option 1 ID : 264330648691

Option 2 ID : 264330648692

Option 3 ID : 264330648693

Option 4 ID : 264330648694

Status : Answered

Chosen Option : 1

Q.26 वातापी चालुक्य निम्नलिखित में से किस राजवंश के सहायक राजकुमार थे?

- Ans
- 1. कल्याणी के चालुक्य
 - 2. पल्लव
 - 3. चोल
 - 4. कदंब

Question ID : 264330106603

Option 1 ID : 264330418716

Option 2 ID : 264330418715

Option 3 ID : 264330418714

Option 4 ID : 264330418713

Status : Answered

Chosen Option : 3

Q.27 कॉलम-A और कॉलम-B के बीच निम्नलिखित में से कौन सा सही मेल है?

कॉलम -A (चट्टान का प्रकार)

कॉलम -B (गठन की विधि)

- | | |
|------------------------|--|
| i. अवसादी-चट्टान | a. अन्य प्रकार की चट्टानों से अपने रासायनिक गुणों को रूपांतरित करके गठित |
| ii. कार्यांतरित चट्टान | b. पृथ्वी की सतह पर उत्क्षेपित या उत्सर्जित मैग्मा से व्युत्पन्न |
| iii. आग्नेय चट्टान | c. अन्य चट्टानों के टुकड़ों या पौधों या जानवरों के अवशेषों से गठित |

- Ans
- 1. i-c, ii-a, iii-b
 - 2. i-a, ii-c, iii-b
 - 3. i-a, ii-b, iii-c
 - 4. i-b, ii-a, iii-c

Question ID : 264330111919

Option 1 ID : 264330439763

Option 2 ID : 264330439764

Option 3 ID : 264330439761

Option 4 ID : 264330439762

Status : Not Answered

Chosen Option : --

Q.28 बेनामी लेनदेन (निषेध) अधिनियम के कुछ प्रावधानों को सुप्रीम कोर्ट ने रद्द कर दिया था। यह कानून मूल रूप से किस वर्ष में अधिनियमित किया गया था?

- Ans
- 1. 1980
 - 2. 1999
 - 3. 1998
 - 4. 1988

Question ID : 264330156982

Option 1 ID : 264330615306

Option 2 ID : 264330615305

Option 3 ID : 264330615303

Option 4 ID : 264330615304

Status : Not Answered

Chosen Option : --

Q.29 नवंबर 2022 में, भारत के 50वें मुख्य न्यायाधीश कौन बने?

- Ans
- 1. जस्टिस एस. अब्दुल नज़ीर
 - 2. जस्टिस डी. वाई. चंद्रचूड़
 - 3. जस्टिस हेमंत गुप्ता
 - 4. जस्टिस इंदिरा बनर्जी

Question ID : 264330158509

Option 1 ID : 264330621395

Option 2 ID : 264330621397

Option 3 ID : 264330621398

Option 4 ID : 264330621396

Status : Answered

Chosen Option : 2

Q.30 निम्नलिखित में से कौन-सा वेद भारत के पूर्व वैदिक काल के लोगों के जीवन का वर्णन करता है और इसमें 10 मंडलों में विभाजित 1028 सूक्तों का संग्रह है?

- Ans
- 1. यजुर्वेद
 - 2. अथर्ववेद
 - 3. ऋग्वेद
 - 4. सामवेद

Question ID : 264330165335

Option 1 ID : 264330648422

Option 2 ID : 264330648419

Option 3 ID : 264330648420

Option 4 ID : 264330648421

Status : Answered

Chosen Option : 3

Q.31 हिमालय में, बढ़ती ऊंचाई के साथ तापमान में _____ वनस्पति में परिवर्तन का कारण बनती है।

- Ans
- 1. कमी
 - 2. उतार-चढ़ाव
 - 3. वृद्धि
 - 4. स्थिरता

Question ID : 264330170002

Option 1 ID : 264330666683

Option 2 ID : 264330666686

Option 3 ID : 264330666684

Option 4 ID : 264330666685

Status : Answered

Chosen Option : 3

Q.32 जलवायु और मौसम में होने वाले सभी परिवर्तन _____ में होते हैं।

- Ans
- 1. क्षोभमंडल
 - 2. तापमंडल
 - 3. समतापमंडल
 - 4. मध्यमंडल

Question ID : 264330117620

Option 1 ID : 264330462507

Option 2 ID : 264330462508

Option 3 ID : 264330462506

Option 4 ID : 264330462505

Status : Answered

Chosen Option : 2

Q.33 1957 में हचिंसन (Hutchinson) द्वारा किसी व्यक्ति या जनसंख्या द्वारा स्वयं के पर्यावरण के सभी पहलुओं के साथ संबंध को व्यक्त करने के लिए कौन-सी अवधारणा प्रस्तावित की गई थी?

- Ans
- 1. पारिस्थितिक पिरामिड
 - 2. पारिस्थितिक स्तरीकरण
 - 3. पारिस्थितिक निकेत
 - 4. पारिस्थितिक अनुक्रम

Question ID : 264330131003

Option 1 ID : 264330513126

Option 2 ID : 264330513125

Option 3 ID : 264330513123

Option 4 ID : 264330513124

Status : Answered

Chosen Option : 1

Q.34 1941 में जहाज निर्माण उद्योग निम्नलिखित में से किस स्थान पर शुरू हुआ था?

- Ans
- 1. दामोदर
 - 2. कुरनूल
 - 3. एलुरु
 - 4. विशाखापट्टनम

Question ID : 264330163214

Option 1 ID : 264330640168

Option 2 ID : 264330640167

Option 3 ID : 264330640170

Option 4 ID : 264330640169

Status : Answered

Chosen Option : 4

Q.35 भारत की जनगणना 2011 के अनुसार राष्ट्रीय महिला श्रमबल भागीदारी दर (female workforce participation rate) क्या है?

- Ans
- 1. 25.51%
 - 2. 53.26%
 - 3. 53.03%
 - 4. 30.02%

Question ID : 264330166820

Option 1 ID : 264330654318

Option 2 ID : 264330654315

Option 3 ID : 264330654317

Option 4 ID : 264330654316

Status : Not Answered

Chosen Option : --

Q.36 कैलाश मंदिर, _____ के अंदर स्थित है।

- Ans
- 1. खंडगिरी गुफाओं
 - 2. अजंता की गुफाओं
 - 3. एलीफंटा गुफाओं
 - 4. एलोरा की गुफाओं

Question ID : 26433066564

Option 1 ID : 264330260781

Option 2 ID : 264330260782

Option 3 ID : 264330260780

Option 4 ID : 264330260783

Status : Answered

Chosen Option : 3

Q.37 36वें राष्ट्रीय खेल 2022 में, किसे सर्वश्रेष्ठ पुरुष एथलीट घोषित किया गया?

- Ans 1. अमलान बोरगोहेन
 2. साजन प्रकाश
 3. अंकुर गोयल
 4. प्रवीण चित्रवेल

Question ID : 264330120051

Option 1 ID : 264330470460

Option 2 ID : 264330470462

Option 3 ID : 264330470461

Option 4 ID : 264330470459

Status : Answered

Chosen Option : 1

Q.38 सरकारी बजट के संदर्भ में निम्नलिखित में से कौन-सा कथन असत्य है?

- Ans 1. भारतीय रेलवे के माध्यम से अर्जित लाभ, गैर-कर राजस्व का एक हिस्सा होता है।
 2. संग्रह/वसूल किया गया शुल्क और जुर्माना पूंजीगत प्राप्ति का एक उदाहरण होता है।
 3. राजस्व प्राप्ति के मामले में राशि वापस करने के लिए कोई भावी बाधता नहीं होती है।
 4. ऋण की वसूली एक पूंजीगत प्राप्ति होती है।

Question ID : 264330109079

Option 1 ID : 264330428595

Option 2 ID : 264330428596

Option 3 ID : 264330428593

Option 4 ID : 264330428594

Status : Answered

Chosen Option : 3

Q.39 शतरंज के खेल का नियम कि 'यह किसी भी दिशा में केवल एक वर्ग चल सकता है' किस पर लागू होता है?

- Ans 1. वज़ीर (The Queen)
 2. बादशाह (The King)
 3. हाथी (The Rook)
 4. ऊंट (The Bishop)

Question ID : 264330109856

Option 1 ID : 264330431702

Option 2 ID : 264330431701

Option 3 ID : 264330431703

Option 4 ID : 264330431704

Status : Answered

Chosen Option : 2

Q.40 निम्नलिखित में से कौन-सा आवश्यक सूक्ष्म पोषक तत्व हेक्सामेरिक रूप में इंसुलिन के संश्लेषण, भंडारण और स्राव के साथ-साथ इंसुलिन की गठनात्मक अखंडता में एक स्पष्ट भूमिका निभाता है?

- Ans 1. फ्लोराइड
 2. जिंक
 3. फॉस्फोरस
 4. सिलीनियम

Question ID : 264330113464

Option 1 ID : 264330445944

Option 2 ID : 264330445941

Option 3 ID : 264330445943

Option 4 ID : 264330445942

Status : Not Answered

Chosen Option : --

Q.41 भारत के आर्द्र पर्णपाती वनों के बारे में निम्नलिखित में से कौन-सा कथन सत्य नहीं है?

- Ans 1. ये हिमालय की तलहटी में पाए जाते हैं।
 2. ये बिहार और उत्तर प्रदेश के मैदानी इलाकों में पाए जाते हैं।
 3. साल, आंवला, शीशम और महुआ इन वनों की कुछ मुख्य प्रजातियाँ हैं।
 4. ये 100-200 cm वर्षा वाले क्षेत्रों में उगते हैं।

Question ID : 264330166805
 Option 1 ID : 264330654258
 Option 2 ID : 264330654256
 Option 3 ID : 264330654257
 Option 4 ID : 264330654255
 Status : Answered
 Chosen Option : 1

Q.42 पंडित रविशंकर किस वाद्य यंत्र के प्रतिपादक हैं?

- Ans 1. सरोद
 2. सितार
 3. सारंगी
 4. वीणा

Question ID : 26433064242
 Option 1 ID : 264330251561
 Option 2 ID : 264330251563
 Option 3 ID : 264330251562
 Option 4 ID : 264330251560
 Status : Answered
 Chosen Option : 2

Q.43 परमाणु क्रमांक को निरूपित करने के लिए हेनरी मोसले (Henry Moseley) ने किस प्रतीक का उपयोग किया था?

- Ans 1. Z
 2. A
 3. M
 4. U

Question ID : 264330137303
 Option 1 ID : 264330537839
 Option 2 ID : 264330537840
 Option 3 ID : 264330537842
 Option 4 ID : 264330537841
 Status : Answered
 Chosen Option : 1

Q.44 पारिवारिक न्यायालय (संशोधन) विधेयक, 2022 निम्नलिखित में से किन राज्यों से संबंधित है?

- Ans 1. त्रिपुरा और असम
 2. नागालैंड और त्रिपुरा
 3. नागालैंड और हिमाचल प्रदेश
 4. हिमाचल प्रदेश और उत्तराखंड

Question ID : 264330158486
 Option 1 ID : 264330621304
 Option 2 ID : 264330621303
 Option 3 ID : 264330621305
 Option 4 ID : 264330621306
 Status : Not Answered
 Chosen Option : --

Q.45 समुद्रगुप्त की उपलब्धियों को उनके दरबारी कवि, _____ द्वारा प्रशस्ति नामक एक लंबे शिलालेख में दर्ज किया गया है।

- Ans
- 1. कल्हण
 - 2. हरिषेण
 - 3. कालिदास
 - 4. रुद्रसेन

Question ID : 264330114811
Option 1 ID : 264330451330
Option 2 ID : 264330451331
Option 3 ID : 264330451332
Option 4 ID : 264330451329
Status : Answered
Chosen Option : 2

Q.46 निम्नलिखित में से किस शहर से राष्ट्रीय सुदूर संवेदन केंद्र, उपग्रह संचार के तहत डेटा के अधिग्रहण और इसके प्रसंस्करण की सुविधा प्रदान करता है?

- Ans
- 1. चेन्नई
 - 2. नई दिल्ली
 - 3. हैदराबाद
 - 4. बेंगलुरु

Question ID : 264330163222
Option 1 ID : 264330640199
Option 2 ID : 264330640200
Option 3 ID : 264330640202
Option 4 ID : 264330640201
Status : Not Answered
Chosen Option : --

Q.47 अंतर्राष्ट्रीय योग दिवस कब मनाया जाता है?

- Ans
- 1. 21 जून को
 - 2. 20 जून को
 - 3. 22 जून को
 - 4. 23 जून को

Question ID : 264330110353
Option 1 ID : 264330433690
Option 2 ID : 264330433689
Option 3 ID : 264330433691
Option 4 ID : 264330433692
Status : Answered
Chosen Option : 3

Q.48 निम्नलिखित में से कौन-सा भारत में हरित क्रांति का सकारात्मक प्रभाव नहीं रहा?

- Ans
- 1. औद्योगिक विकास हुआ
 - 2. खाद्यान्न का आयात घटा
 - 3. गैर-खाद्य अनाजों को बाहर रखा गया
 - 4. किसानों को लाभ हुआ

Question ID : 26433064538
Option 1 ID : 264330252746
Option 2 ID : 264330252744
Option 3 ID : 264330252747
Option 4 ID : 264330252745
Status : Answered
Chosen Option : 1

Q.49 पद्म श्री से सम्मानित, भरतनाट्यम, कुचिपुडी और सत्रीया नृत्यों की अंतरराष्ट्रीय स्तर पर प्रशंसित प्रतिपादक, इंदिरा पी.पी. बोरा भारत के किस राज्य से संबंधित हैं?

- Ans
- 1. पश्चिम बंगाल
 - 2. तमिलनाडु
 - 3. असम
 - 4. केरल

Question ID : 264330144843

Option 1 ID : 264330567630

Option 2 ID : 264330567628

Option 3 ID : 264330567627

Option 4 ID : 264330567629

Status : Answered

Chosen Option : 1

Q.50 दवाओं (मेडिसिन) के रूप में इस्तेमाल की जाने वाली औषधियां (ड्रग्स) कब संभावित विष बन जाती हैं?

- Ans
- 1. जब अनुशंसित खुराक से कम खुराक ली जाती है
 - 2. जब अनुशंसित समय पर और अनुशंसित मात्रा में खुराक ली जाती है
 - 3. जब अनुशंसा के अनुसार खुराक ली जाती है
 - 4. जब अनुशंसित खुराक से अधिक खुराक ली जाती है

Question ID : 264330111560

Option 1 ID : 264330438325

Option 2 ID : 264330438328

Option 3 ID : 264330438327

Option 4 ID : 264330438326

Status : Answered

Chosen Option : 4

Section : English Language and Comprehension

Q.1 Select the option that expresses the given sentence in direct speech.
The travel agent asked whether I wanted to go by air or by sea.

- Ans
- 1. The travel agent asked, "How did you want to go by air or sea?"
 - 2. The travel agent asked, "Did you want to go by air or sea?"
 - 3. The travel agent asked, "Did he want to go by air or sea?"
 - 4. The travel agent asked, "Do you want to go by air or sea?"

Question ID : 264330137437

Option 1 ID : 264330538377

Option 2 ID : 264330538376

Option 3 ID : 264330538375

Option 4 ID : 264330538378

Status : Answered

Chosen Option : 4

Q.2 The following sentence has been split into four segments. Identify the segment that contains a grammatical error.

I love the dogs /; but I don't like / the dog my friend Tinzie / owns since it bites people.

- Ans
- 1. I love the dogs
 - 2. owns since it bites people
 - 3. the dog my friend Tinzie
 - 4. ; but I don't like

Question ID : 264330137224

Option 1 ID : 264330537527

Option 2 ID : 264330537530

Option 3 ID : 264330537529

Option 4 ID : 264330537528

Status : Answered

Chosen Option : 2

Q.3 Select the option that expresses the given sentence in passive voice.
Those kids always watch cartoon movies.

- Ans
- 1. Cartoon movies are watching by those kids always.
 - 2. Cartoon movies are watched by those kids always.
 - 3. Cartoon movies watched by those kids always.
 - 4. Cartoon movies were watched by those kids always.

Question ID : 264330164357

Option 1 ID : 264330644642

Option 2 ID : 264330644639

Option 3 ID : 264330644641

Option 4 ID : 264330644640

Status : Answered

Chosen Option : 2

Q.4 Select the most appropriate option that can substitute the underlined segment in the given sentence. If there is no need to substitute it, select 'No substitution required'.

Though I was not happy, I went to the reception because of the sake of my friend.

- Ans
- 1. I went to the reception for the sake of my friend
 - 2. I will go to the reception for the sake of my friend
 - 3. I have gone to the reception because of the sake of my friend
 - 4. I went for the reception for the sake of my friend

Question ID : 26433091874

Option 1 ID : 264330360833

Option 2 ID : 264330360834

Option 3 ID : 264330360836

Option 4 ID : 264330360835

Status : Answered

Chosen Option : 1

Q.5 Select the most appropriate ANTONYM of the given word.
Mercurial

- Ans
- 1. Flippant
 - 2. Bereaved
 - 3. Tranquil
 - 4. Salacious

Question ID : 264330168041
Option 1 ID : 264330659054
Option 2 ID : 264330659053
Option 3 ID : 264330659052
Option 4 ID : 264330659051
Status : Answered
Chosen Option : 3

Q.6 Select the option that expresses the given sentence in indirect speech.
She said, "I will dance tomorrow."

- Ans
- 1. She said that she would dance the next day.
 - 2. She said that she would dance tomorrow.
 - 3. She said she would dance the next day.
 - 4. She said that she will dance tomorrow.

Question ID : 264330168351
Option 1 ID : 264330660270
Option 2 ID : 264330660268
Option 3 ID : 264330660269
Option 4 ID : 264330660267
Status : Answered
Chosen Option : 1

Q.7 Select the option that changes the form of narration in the following sentence.

Rohan said, "I didn't tell any lie to anyone."

- Ans
- 1. Rohan said that I did not tell any lie to anyone.
 - 2. Rohan said that he did not tell any lie to anyone.
 - 3. Rohan said that I had not told any lie to anyone.
 - 4. Rohan said that he had not told any lie to anyone.

Question ID : 264330163267
Option 1 ID : 264330640382
Option 2 ID : 264330640379
Option 3 ID : 264330640380
Option 4 ID : 264330640381
Status : Answered
Chosen Option : 4

Q.8 Sentences of a paragraph are given below in jumbled order. Arrange the sentences in the correct order to form a meaningful and coherent paragraph.

- A. Changes in the nature of light are brought on by the Raman Effect.
- B. It examines how light behaves when it passes through a solid, liquid, or gaseous transparent media.
- C. Similar to how a striker scatters coins on a carom board, the phenomenon occurs when light energy particles called photons are scattered by the medium's molecules.
- D. Understanding the molecular structure of chemical molecules requires knowledge of the Raman Effect.

- Ans
- 1. BCDA
 - 2. ABCD
 - 3. CBDA
 - 4. CABD

Question ID : 264330117158
Option 1 ID : 264330460697
Option 2 ID : 264330460698
Option 3 ID : 264330460699
Option 4 ID : 264330460700
Status : Answered
Chosen Option : 2

Q.9 Select the option that expresses the given sentence in passive voice.
The company produces high-quality products.

- Ans
- 1. High-quality products are produced by the company.
 - 2. High-quality products produced by the company.
 - 3. High-quality products are being produced by the company.
 - 4. High-quality products were produced by the company.

Question ID : 264330168229
Option 1 ID : 264330659792
Option 2 ID : 264330659794
Option 3 ID : 264330659793
Option 4 ID : 264330659791
Status : Answered
Chosen Option : 1

Q.10 Select the most appropriate option to fill in the blank.

Dust has _____ in the crevices of the house.

- Ans
- 1. flown
 - 2. gathered
 - 3. assembled
 - 4. lived

Question ID : 26433098897
Option 1 ID : 264330388241
Option 2 ID : 264330388242
Option 3 ID : 264330388243
Option 4 ID : 264330388244
Status : Answered
Chosen Option : 2

Q.11 Select the option that expresses the given sentence in active voice.
A story has been written by Sarath.

- Ans
- 1. Sarath have written a story.
 - 2. Sarath wrote a story.
 - 3. Sarath has written a story.
 - 4. Sarath was written by a story.

Question ID : 264330164354
Option 1 ID : 264330644628
Option 2 ID : 264330644630
Option 3 ID : 264330644629
Option 4 ID : 264330644627
Status : Answered
Chosen Option : 3

Q.12 Select the most appropriate option that can substitute the underlined segment in the given sentence.

Drop me a message when the food will be ready.

- Ans
- 1. the food shall be ready
 - 2. the food will ready
 - 3. the food will be prepared
 - 4. the food is ready

Question ID : 264330117264
Option 1 ID : 264330461114
Option 2 ID : 264330461113
Option 3 ID : 264330461116
Option 4 ID : 264330461115
Status : Answered
Chosen Option : 4

Q.13 Select the most appropriate meaning of the given idiom.
Up in arms

- Ans
- 1. Standing tall
 - 2. Doing exercise
 - 3. Unable to do something
 - 4. Ready to fight

Question ID : 264330135899
Option 1 ID : 264330532453
Option 2 ID : 264330532451
Option 3 ID : 264330532454
Option 4 ID : 264330532452
Status : Answered
Chosen Option : 3

Q.14 Select the most appropriate ANTONYM of the given word.
Mitigate

- Ans
- 1. Aggravate
 - 2. Reform
 - 3. Mend
 - 4. Sharpen

Question ID : 264330165264
Option 1 ID : 264330648149
Option 2 ID : 264330648148
Option 3 ID : 264330648147
Option 4 ID : 264330648150
Status : Answered
Chosen Option : 1

Q.15 Select the option that expresses the given sentence in direct speech.
The teacher reminded the students to submit their assignments by Friday.

- Ans
- 1. "Submit your assignments by Friday," reminded the teacher to the students.
 - 2. "Submit your assignments by Friday," the teacher reminded the students.
 - 3. "Submit your assignments by Friday," the students were instructed by the teacher.
 - 4. "Submit your assignments by Friday," the students were reminded by the teacher.

Question ID : 264330137489
Option 1 ID : 264330538575
Option 2 ID : 264330538576
Option 3 ID : 264330538578
Option 4 ID : 264330538577
Status : Answered
Chosen Option : 2

Q.16 Parts of the following sentence have been given as options. One of them may contain an error. Select the part that contains the error from the given options. If you don't find any error, mark 'No error' as your answer.

I have never played a hero before, so I jump at the chance.

- Ans
- 1. a hero before
 - 2. No error
 - 3. I have never played
 - 4. So I jump at the chance

Question ID : 26433090488
Option 1 ID : 264330355402
Option 2 ID : 264330355404
Option 3 ID : 264330355401
Option 4 ID : 264330355403
Status : Answered
Chosen Option : 4

Q.17 Select the most appropriate ANTONYM of the given word.
Duty

- Ans 1. Loophole
 2. Exemption
 3. Option
 4. Selection

Question ID : 264330170181
Option 1 ID : 264330667401
Option 2 ID : 264330667402
Option 3 ID : 264330667399
Option 4 ID : 264330667400
Status : Answered
Chosen Option : 3

Q.18 Select the most appropriate ANTONYM of the given word.
Carry

- Ans 1. Haul
 2. Take
 3. Transfer
 4. Leave

Question ID : 264330168296
Option 1 ID : 264330660047
Option 2 ID : 264330660049
Option 3 ID : 264330660048
Option 4 ID : 264330660050
Status : Answered
Chosen Option : 4

Q.19 Select the most appropriate option that can substitute the underlined segment in the given sentence.
The heart that is full of grieve is heavy.

- Ans 1. full of grieving
 2. filling with grief
 3. filled with grieve
 4. full of grief

Question ID : 264330117048
Option 1 ID : 264330460274
Option 2 ID : 264330460276
Option 3 ID : 264330460273
Option 4 ID : 264330460275
Status : Answered
Chosen Option : 4

Q.20 Select the most appropriate option to substitute the underlined segment in the given sentence.

Vishnu was happy to push the boat out for his fiancée's birthday.

- Ans
- 1. but seemed like pretending on
 - 2. to take risks that could cause problems or danger on
 - 3. and felt so, that his heart started beating faster on
 - 4. to spend a lot of money because he was celebrating

Question ID : 264330164687

Option 1 ID : 264330645918

Option 2 ID : 264330645915

Option 3 ID : 264330645917

Option 4 ID : 264330645916

Status : Answered

Chosen Option : 2

Q.21 Select the most appropriate option that can substitute the underlined segment in the given sentence.

To take my parents on a pilgrimage by plane is one of the goal of my life after getting my first salary.

- Ans
- 1. one of goal of my life
 - 2. one of the goals of my life
 - 3. one of out of the goals of my life
 - 4. one in the goal of my life

Question ID : 26433096160

Option 1 ID : 264330377409

Option 2 ID : 264330377411

Option 3 ID : 264330377410

Option 4 ID : 264330377412

Status : Answered

Chosen Option : 2

Q.22 Select the option that changes the form of narration in the following sentence.

The priest said to the convict, "Are you not ashamed of your misdeed?"

- Ans
- 1. The priest enquired of the convict that she was not ashamed of her misdeed.
 - 2. The priest enquired of the convict if she was not ashamed of her misdeed.
 - 3. The priest enquired the convict of whether she is not ashamed of her misdeed.
 - 4. The priest enquired of the convict if was she not ashamed of her misdeed.

Question ID : 264330163268

Option 1 ID : 264330640384

Option 2 ID : 264330640383

Option 3 ID : 264330640385

Option 4 ID : 264330640386

Status : Answered

Chosen Option : 2

- Q.23 Sentences of a paragraph are given below in jumbled order. Arrange the sentences in the correct logical order to form a meaningful and coherent paragraph.
 A.A variety of diseases can be linked to unsanitary conditions and careless garbage disposal.
 B.People understand the value of cleanliness but they often forget that they are also responsible for the cleanliness of the environment, that they are accountable for whatever waste they make and that simply getting rid of it from their homes will not help.
 C.A clean and green environment is a fundamental tenet of sustainable development.
 D.It could be due to a lack of information, pure laziness, or recklessness. Sometimes all it takes is a gentle nudge.

- Ans 1. CBDA
 2. BDCA
 3. CABD
 4. ACDB

Question ID : 264330117484
 Option 1 ID : 264330461961
 Option 2 ID : 264330461962
 Option 3 ID : 264330461964
 Option 4 ID : 264330461963
 Status : Answered
 Chosen Option : 1

- Q.24 The following sentence has been divided into segments. One of them may contain an error. Select the segment that contains the error from the given options. If you don't find any error, mark 'No error' as your answer.

Ignoring the red flag / warning in the beach / is no joke.

- Ans 1. warning in the beach
 2. No Error
 3. Ignoring the red flag
 4. is no joke.

Question ID : 26433096147
 Option 1 ID : 264330377358
 Option 2 ID : 264330377360
 Option 3 ID : 264330377357
 Option 4 ID : 264330377359
 Status : Answered
 Chosen Option : 1

- Q.25 Select the most appropriate synonym of the underlined word in the following sentence.
 The coach's instructions were concise, providing clear guidance to the team.

- Ans 1. Many
 2. Brief
 3. Verbose
 4. Lengthy

Question ID : 264330164642
 Option 1 ID : 264330645750
 Option 2 ID : 264330645749
 Option 3 ID : 264330645748
 Option 4 ID : 264330645747
 Status : Answered
 Chosen Option : 2

Q.26 Select the option that can substitute the bracketed word segment correctly and complete the following sentence meaningfully.
They didn't see you coming here, (is it)?

- Ans
- 1. didn't you
 - 2. did you
 - 3. didn't they
 - 4. did they

Question ID : 264330134147
Option 1 ID : 264330525614
Option 2 ID : 264330525613
Option 3 ID : 264330525612
Option 4 ID : 264330525611
Status : Answered
Chosen Option : 4

Q.27 The following sentence has been split into four segments. Identify the segment that contains a grammatical error.
Please tell me the truth, / is he here to have been investigating / the murder that / happened across the street?

- Ans
- 1. happened across the street
 - 2. Please tell me the truth,
 - 3. the murder that
 - 4. is he here to have been investigating

Question ID : 264330133410
Option 1 ID : 264330522674
Option 2 ID : 264330522671
Option 3 ID : 264330522673
Option 4 ID : 264330522672
Status : Answered
Chosen Option : 4

Q.28 Select the option that expresses the given sentence in direct speech.

The teacher told the students that she had waited for them for about 15 minutes before leaving the class.

- Ans
- 1. The teacher says, "I had waited for you for about 15 minutes before leaving the class."
 - 2. The teacher had said, "I had waited for you for about 15 minutes before leaving the class."
 - 3. The teacher said to the students, "I could waited for you for about 15 minutes before leaving the class."
 - 4. The teacher said to the students, "I waited for you for about 15 minutes before leaving the class."

Question ID : 26433099081
Option 1 ID : 264330388958
Option 2 ID : 264330388959
Option 3 ID : 264330388957
Option 4 ID : 264330388960
Status : Answered
Chosen Option : 4

Q.29 Select the most appropriate option to fill in the blank.

No parents _____ to see their children ruin their future.

- Ans
- 1. visualise
 - 2. think
 - 3. wish
 - 4. predict

Question ID : 26433098895
Option 1 ID : 264330388233
Option 2 ID : 264330388234
Option 3 ID : 264330388235
Option 4 ID : 264330388236
Status : Answered
Chosen Option : 3

Q.30 Select the most appropriate option that can substitute the underlined segment in the given sentence.

Some teachers often praise their pupils' efforts while some use ridicule and irony.

- Ans
- 1. abuse
 - 2. vigilant
 - 3. sarcasm
 - 4. appreciation

Question ID : 264330117323
Option 1 ID : 264330461351
Option 2 ID : 264330461349
Option 3 ID : 264330461350
Option 4 ID : 264330461352
Status : Answered
Chosen Option : 3

Q.31 Select the most appropriate preposition to fill in the blank.

Are you afraid _____ the dark?

- Ans
- 1. at
 - 2. on
 - 3. of
 - 4. to

Question ID : 264330164312
Option 1 ID : 264330644463
Option 2 ID : 264330644465
Option 3 ID : 264330644466
Option 4 ID : 264330644464
Status : Answered
Chosen Option : 3

Q.32 The following sentence has been split into four segments. Identify the segment that contains a grammatical error.

I do not like / your paying / for the food / every time.

- Ans
- 1. every time
 - 2. your paying
 - 3. for the food
 - 4. I do not like

Question ID : 264330102135
Option 1 ID : 264330401008
Option 2 ID : 264330401006
Option 3 ID : 264330401007
Option 4 ID : 264330401005
Status : Answered
Chosen Option : 2

Q.33 Select the most appropriate option that can substitute the underlined segment in the given sentence.

When Shruti called Naufal, he was given the team a briefing of the project.

- Ans
- 1. has been giving the team a briefing of
 - 2. had been given the team a briefing of
 - 3. was giving the team a briefing of
 - 4. was gave the team a briefing of

Question ID : 264330100999
Option 1 ID : 264330396542
Option 2 ID : 264330396543
Option 3 ID : 264330396544
Option 4 ID : 264330396541
Status : Answered
Chosen Option : 3

Q.34 Select the most appropriate synonym of the underlined word to fill in the blank.

He has a melancholic temperament; he is often _____.

- Ans
- 1. gloomy
 - 2. curious
 - 3. enthusiastic
 - 4. glad

Question ID : 264330164195
Option 1 ID : 264330644030
Option 2 ID : 264330644027
Option 3 ID : 264330644029
Option 4 ID : 264330644028
Status : Answered
Chosen Option : 1

Q.35 Select the most appropriate meaning for the given idiom.
Fall into line

- Ans
- 1. Searching something
 - 2. Fuming and shouting
 - 3. Straight road to walk
 - 4. Adhere to rules

Question ID : 264330168304
Option 1 ID : 264330660079
Option 2 ID : 264330660081
Option 3 ID : 264330660082
Option 4 ID : 264330660080
Status : Answered
Chosen Option : 4

Q.36 Identify the ANTONYM of the following word in the given sentence.

Furious

The frantic leader was outraged at the failure of his subordinate who unexpectedly was unperturbed.

- Ans
- 1. outraged
 - 2. unperturbed
 - 3. failure
 - 4. frantic

Question ID : 264330135897
Option 1 ID : 264330532444
Option 2 ID : 264330532446
Option 3 ID : 264330532445
Option 4 ID : 264330532443
Status : Answered
Chosen Option : 2

Q.37 Select the most appropriate option to fill in the blank.

The chemical spray is a very useful and distant weapon that may be used to attack from a long distance, _____ additional safety.

- Ans
- 1. minimising
 - 2. developing
 - 3. ensuring
 - 4. following

Question ID : 26433098917
Option 1 ID : 264330388324
Option 2 ID : 264330388322
Option 3 ID : 264330388321
Option 4 ID : 264330388323
Status : Answered
Chosen Option : 3

Q.38 Select the most appropriate ANTONYM of the given word.
Grandeur

- Ans 1. Insignificance
 2. Assignment
 3. Greatness
 4. Permission

Question ID : 264330139384
Option 1 ID : 264330545987
Option 2 ID : 264330545989
Option 3 ID : 264330545990
Option 4 ID : 264330545988
Status : Answered
Chosen Option : 1

Q.39 The following sentence has been divided into parts. One of them may contain an error.
Select the part that contains the error from the given options. If you don't find any error, mark 'No error' as your answer.
If you permit me, / I will bring and show / all my drawings to you.

- Ans 1. No error
 2. all my drawings to you
 3. I will bring and show
 4. If you permit me,

Question ID : 264330139154
Option 1 ID : 264330545194
Option 2 ID : 264330545193
Option 3 ID : 264330545192
Option 4 ID : 264330545191
Status : Answered
Chosen Option : 1

Q.40 Select the most appropriate option that can substitute the underlined segment in the given sentence.

The boy tried to complete the task on time because he didn't want to miss farther tasks.

- Ans 1. doesn't want to miss further tasks
 2. didn't want of miss farther tasks
 3. doesn't want to miss farther tasks
 4. didn't want to miss further tasks

Question ID : 264330100993
Option 1 ID : 264330396518
Option 2 ID : 264330396519
Option 3 ID : 264330396517
Option 4 ID : 264330396520
Status : Answered
Chosen Option : 4

Q.41 The following sentence has been split into four segments. Identify the segment that contains a grammatical error.
The judge decided that / the defendant was guilty of all charges, / and that a punishment of five years / in prison were appropriate.

- Ans
- 1. The judge decided that
 - 2. the defendant was guilty of all charges,
 - 3. in prison were appropriate
 - 4. and that a punishment of five years

Question ID : 264330137470
Option 1 ID : 264330538499
Option 2 ID : 264330538500
Option 3 ID : 264330538502
Option 4 ID : 264330538501
Status : Answered
Chosen Option : 3

Q.42 Select the option that expresses the following sentence in passive voice.
Agnes composed a song for her father's birthday.

- Ans
- 1. A song would have been composed by Agnes for her father's birthday.
 - 2. A song was being composed by Agnes for her father's birthday.
 - 3. A song had been composed by Agnes for her father's birthday.
 - 4. A song was composed by Agnes for her father's birthday.

Question ID : 264330164386
Option 1 ID : 264330644758
Option 2 ID : 264330644757
Option 3 ID : 264330644755
Option 4 ID : 264330644756
Status : Answered
Chosen Option : 4

Q.43 Select the most appropriate ANTONYM of the given word.
Abundance

- Ans
- 1. Miser
 - 2. Meagreness
 - 3. Non-serious
 - 4. Unpleasantness

Question ID : 264330137460
Option 1 ID : 264330538465
Option 2 ID : 264330538464
Option 3 ID : 264330538466
Option 4 ID : 264330538463
Status : Answered
Chosen Option : 2

Q.44 Select the most appropriate meaning of the underlined idiom in the following sentence.

After having worked on the study non-stop for twenty-three years, Harvey finally called it a day last week.

- Ans
- 1. Honed a new skill
 - 2. Started a new job
 - 3. Stopped working on something
 - 4. Decided to revise

Question ID : 264330168045
Option 1 ID : 264330659070
Option 2 ID : 264330659068
Option 3 ID : 264330659069
Option 4 ID : 264330659067
Status : Answered
Chosen Option : 3

Q.45 Select the most appropriate option to fill in the blank.

The most evident reason for cases pending in the Indian judiciary is an _____ representation of judges.

- Ans
- 1. optimised
 - 2. adequate
 - 3. unlawful
 - 4. insufficient

Question ID : 26433098915
Option 1 ID : 264330388316
Option 2 ID : 264330388315
Option 3 ID : 264330388313
Option 4 ID : 264330388314
Status : Answered
Chosen Option : 4

Q.46 Select the most appropriate option to fill in the blank.

Except the editing, all the other relevant parts of the movie _____.

- Ans
- 1. was excellent
 - 2. are excellent
 - 3. is excellent
 - 4. are being excellent

Question ID : 264330117214
Option 1 ID : 264330460920
Option 2 ID : 264330460919
Option 3 ID : 264330460917
Option 4 ID : 264330460918
Status : Answered
Chosen Option : 2

Q.47 Select the most appropriate ANTONYM of the given word.
Advent

- Ans 1. Departure
 2. Arrival
 3. Experience
 4. Attraction

Question ID : 264330168280
Option 1 ID : 264330659989
Option 2 ID : 264330659987
Option 3 ID : 264330659990
Option 4 ID : 264330659988
Status : Answered
Chosen Option : 1

Q.48 Select the most appropriate option that can substitute the underlined segment in the given sentence.

River rafting is an adventure sport in which a group of five people levitate through a river in an inflatable raft.

- Ans 1. deviate through a river
 2. navigate through a river
 3. alleviate through a river
 4. assemble through a river

Question ID : 26433096164
Option 1 ID : 264330377425
Option 2 ID : 264330377427
Option 3 ID : 264330377426
Option 4 ID : 264330377428
Status : Answered
Chosen Option : 2

Q.49 Identify the ANTONYM of the following word in the given sentence.

Lethargy

The usually circumspect personnel's vigour for his duty was visible in his dealing with customers.

- Ans 1. vigour
 2. visible
 3. circumspect
 4. usually

Question ID : 264330135896
Option 1 ID : 264330532441
Option 2 ID : 264330532442
Option 3 ID : 264330532440
Option 4 ID : 264330532439
Status : Answered
Chosen Option : 1

Q.50 Select the option that expresses the given sentence in active voice.
Your homework must be completed before the deadline.

- Ans
- 1. You must complete your homework before the deadline.
 - 2. Your homework must have been completed before the deadline.
 - 3. You must have completed your homework before the deadline.
 - 4. Your homework should be completed before the deadline.

Question ID : 264330164245
Option 1 ID : 264330644212
Option 2 ID : 264330644211
Option 3 ID : 264330644214
Option 4 ID : 264330644213
Status : Answered
Chosen Option : 1

Q.51 Select the option that expresses the given sentence in direct speech.
Manas said that Sooraj had arrived on Friday.

- Ans
- 1. Manas says, "Sooraj has be arrives on Friday."
 - 2. Manas said, "Sooraj arrived on Friday."
 - 3. Manas say, "Sooraj arriving on Friday."
 - 4. Manas says, "Sooraj is arrived on Friday."

Question ID : 264330135986
Option 1 ID : 264330532790
Option 2 ID : 264330532788
Option 3 ID : 264330532787
Option 4 ID : 264330532789
Status : Answered
Chosen Option : 2

Q.52 The following sentence has been split into four segments. Identify the segment that contains a grammatical error.

The school authorities are / decided to close the high school / wing for the next three days / due to power failure.

- Ans
- 1. The school authorities are
 - 2. wing for the next three days
 - 3. due to power failure
 - 4. decided to close the high school

Question ID : 26433091955
Option 1 ID : 264330361157
Option 2 ID : 264330361159
Option 3 ID : 264330361160
Option 4 ID : 264330361158
Status : Answered
Chosen Option : 1

Q.53 Select the option that expresses the given sentence in passive voice.
You should eat fresh fruits.

- Ans
- 1. Fresh fruits should be eaten by you.
 - 2. Fresh fruits should be ate by you.
 - 3. Fresh fruits should eat by you.
 - 4. Fresh fruits should be eat by you.

Question ID : 264330132777
Option 1 ID : 264330520203
Option 2 ID : 264330520205
Option 3 ID : 264330520204
Option 4 ID : 264330520206
Status : Answered
Chosen Option : 1

Q.54 Select the option that expresses the given sentence in active voice.

Human life will be prolonged by a new drug called new-med.

- Ans
- 1. A new drug called new-med was prolonging human life.
 - 2. A new drug called new-med is prolonging human life.
 - 3. A new drug called new-med had prolonged human life.
 - 4. A new drug called new-med will prolong human life.

Question ID : 26433089121
Option 1 ID : 264330350002
Option 2 ID : 264330350001
Option 3 ID : 264330350004
Option 4 ID : 264330350003
Status : Answered
Chosen Option : 4

Q.55 Sentences of a paragraph are given below in jumbled order. Arrange the sentences in the correct order to form a meaningful and coherent paragraph.

A.Targeted advertising is playing an increasingly important role in social media marketing.

B.It wasn't until a few years ago that people began to perceive social media as a marketing tool.

C.Social media has long been regarded as a means of communicating with people via instant messaging and blogging.

D.In marketing, social media is a quick and easy means to share a company's information, such as advertising and products or services available to customers.

- Ans
- 1. CBDA
 - 2. DCBA
 - 3. DBCA
 - 4. ACDB

Question ID : 26433097528
Option 1 ID : 264330382787
Option 2 ID : 264330382785
Option 3 ID : 264330382788
Option 4 ID : 264330382786
Status : Answered
Chosen Option : 1

Q.56 Select the option that expresses the following sentence in direct speech.

The judge commanded them to call the first witness.

- Ans 1. The first witness was commanded to come in.
 2. "Please call the first witness," the judge pleaded.
 3. The judge commanded the first witness to come in.
 4. "Call the first witness," said the judge.

Question ID : 264330164201

Option 1 ID : 264330644054

Option 2 ID : 264330644051

Option 3 ID : 264330644053

Option 4 ID : 264330644052

Status : Answered

Chosen Option : 4

Q.57 Sentences of a paragraph are given below in jumbled order. Arrange the sentences in the correct order to form a meaningful and coherent paragraph.

- A. It marked the 5th World Council for the Welfare of the Blind in Sao Paulo.
B. The first Braille stamp was published by Canada Post in 2008.
C. Brazil, however, purchased the first raised-dot Braille stamp in the world in 1974.
D. It featured a yellow Labrador retriever guide dog, a species that is frequently used to assist the blind.

- Ans 1. ABCD
 2. CBAD
 3. DCAB
 4. BDCA

Question ID : 26433098151

Option 1 ID : 264330385257

Option 2 ID : 264330385260

Option 3 ID : 264330385259

Option 4 ID : 264330385258

Status : Answered

Chosen Option : 4

Q.58 Select the option that expresses the given sentence in active voice.

I was given this book by my English teacher.

- Ans 1. This book was given to me by my English teacher.
 2. My English teacher gave me this book.
 3. My English teacher was given this book by me.
 4. This book gave me my English teacher.

Question ID : 264330164592

Option 1 ID : 264330645551

Option 2 ID : 264330645552

Option 3 ID : 264330645553

Option 4 ID : 264330645554

Status : Answered

Chosen Option : 2

Q.59 Select the most appropriate option that can substitute the underlined segment in the given sentence.

He asked me what is my name?

- Ans
- 1. what is my name.
 - 2. what my name has been.
 - 3. what my name was.
 - 4. what was my name?

Question ID : 264330117259
Option 1 ID : 264330461094
Option 2 ID : 264330461096
Option 3 ID : 264330461093
Option 4 ID : 264330461095
Status : Answered
Chosen Option : 3

Q.60 Select the most appropriate option that can substitute the underlined segment in the given sentence.

I am very tired and need a chair to sit.

- Ans
- 1. need a chair to sit for
 - 2. need a chair to sit on
 - 3. need a chair to sit by
 - 4. need a chair to sit with

Question ID : 264330117268
Option 1 ID : 264330461131
Option 2 ID : 264330461129
Option 3 ID : 264330461130
Option 4 ID : 264330461132
Status : Answered
Chosen Option : 2

Q.61 Select the option that expresses the following sentence in direct speech.

He requested him to wait there till he returned.

- Ans
- 1. He asked him to wait here till here returns.
 - 2. "Wait here till I return please!" he ordered.
 - 3. He said to him, "Please wait here till I return."
 - 4. "Till he returns, please wait here," he requested.

Question ID : 264330164202
Option 1 ID : 264330644056
Option 2 ID : 264330644055
Option 3 ID : 264330644058
Option 4 ID : 264330644057
Status : Answered
Chosen Option : 3

Q.62 In the following questions a statement has been given with highlighted text. Select the options that can replace the text with correct idiom or phrase.
The trainee performed the task with extreme ease.

- Ans 1. A piece of cake
 2. Swan song
 3. Call it a day
 4. At the eleventh hour

Question ID : 264330120756
Option 1 ID : 264330473239
Option 2 ID : 264330473241
Option 3 ID : 264330473242
Option 4 ID : 264330473240
Status : Answered
Chosen Option : 1

Q.63 Select the most appropriate option that can substitute the underlined segment in the given sentence.

She is too good and real.

- Ans 1. more good and real
 2. very good but real
 3. too good to be real
 4. too good but real

Question ID : 264330117269
Option 1 ID : 264330461133
Option 2 ID : 264330461136
Option 3 ID : 264330461134
Option 4 ID : 264330461135
Status : Answered
Chosen Option : 2

Q.64 Select the option that expresses the given sentence in passive voice.
Look at the clock.

- Ans 1. Let the clock be looked at.
 2. Let looked at the clock.
 3. Let the clock look at.
 4. Let the clock be look at.

Question ID : 264330132775
Option 1 ID : 264330520198
Option 2 ID : 264330520196
Option 3 ID : 264330520197
Option 4 ID : 264330520195
Status : Answered
Chosen Option : 1

Q.65 Select the most appropriate idiom for the underlined word segment.
Low count of sales, despite the sincere efforts of the sales executive, has put her team in a very difficult situation to escape from.

- Ans
- 1. Right off the bat
 - 2. Cut to the chase
 - 3. Bury the hatchet
 - 4. In a tight corner

Question ID : 264330167998

Option 1 ID : 264330658884

Option 2 ID : 264330658885

Option 3 ID : 264330658886

Option 4 ID : 264330658883

Status : Answered

Chosen Option : 4

Comprehension:

In the following passage, some words have been deleted. Read the passage carefully and select the most appropriate option to fill in each blank.

Cambridge University Press (1)_____ no responsibility for the persistence or accuracy of URLs for external or third-party internet websites referred to in (2)_____ publication, and (3)_____ guarantee that any content on such websites is, or will remain, accurate or appropriate. Information (4)_____ prices, travel timetables and other factual (5)_____ given in this work is correct at the time of first printing.

SubQuestion No : 66

Q.66 Select the most appropriate option to fill in blank no.1.

- Ans
- 1. have
 - 2. has
 - 3. and
 - 4. had

Question ID : 264330167897

Option 1 ID : 264330658512

Option 2 ID : 264330658511

Option 3 ID : 264330658514

Option 4 ID : 264330658513

Status : Answered

Chosen Option : 2

Comprehension:

In the following passage, some words have been deleted. Read the passage carefully and select the most appropriate option to fill in each blank.

Cambridge University Press (1)_____ no responsibility for the persistence or accuracy of URLs for external or third-party internet websites referred to in (2)_____ publication, and (3)_____ guarantee that any content on such websites is, or will remain, accurate or appropriate. Information (4)_____ prices, travel timetables and other factual (5)_____ given in this work is correct at the time of first printing.

SubQuestion No : 67**Q.67 Select the most appropriate option to fill in blank no.2.**

- Ans 1. this
 2. that
 3. here
 4. there

Question ID : 264330167898

Option 1 ID : 264330658516

Option 2 ID : 264330658515

Option 3 ID : 264330658518

Option 4 ID : 264330658517

Status : Answered

Chosen Option : 1

Comprehension:

In the following passage, some words have been deleted. Read the passage carefully and select the most appropriate option to fill in each blank.

Cambridge University Press (1)_____ no responsibility for the persistence or accuracy of URLs for external or third-party internet websites referred to in (2)_____ publication, and (3)_____ guarantee that any content on such websites is, or will remain, accurate or appropriate. Information (4)_____ prices, travel timetables and other factual (5)_____ given in this work is correct at the time of first printing.

SubQuestion No : 68**Q.68 Select the most appropriate option to fill in blank no.3.**

- Ans 1. do not
 2. have not
 3. did not
 4. does not

Question ID : 264330167899

Option 1 ID : 264330658519

Option 2 ID : 264330658522

Option 3 ID : 264330658521

Option 4 ID : 264330658520

Status : Answered

Chosen Option : 4

Comprehension:

In the following passage, some words have been deleted. Read the passage carefully and select the most appropriate option to fill in each blank.

Cambridge University Press (1)_____ no responsibility for the persistence or accuracy of URLs for external or third-party internet websites referred to in (2)_____ publication, and (3)_____ guarantee that any content on such websites is, or will remain, accurate or appropriate. Information (4)_____ prices, travel timetables and other factual (5)_____ given in this work is correct at the time of first printing.

SubQuestion No : 69**Q.69 Select the most appropriate option to fill in blank no.4.**

- Ans 1. obstructing
 2. concerned
 3. regarding
 4. related

Question ID : 264330167900

Option 1 ID : 264330658525

Option 2 ID : 264330658524

Option 3 ID : 264330658526

Option 4 ID : 264330658523

Status : Answered

Chosen Option : 3

Comprehension:

In the following passage, some words have been deleted. Read the passage carefully and select the most appropriate option to fill in each blank.

Cambridge University Press (1)_____ no responsibility for the persistence or accuracy of URLs for external or third-party internet websites referred to in (2)_____ publication, and (3)_____ guarantee that any content on such websites is, or will remain, accurate or appropriate. Information (4)_____ prices, travel timetables and other factual (5)_____ given in this work is correct at the time of first printing.

SubQuestion No : 70**Q.70 Select the most appropriate option to fill in blank no.5.**

- Ans 1. opinions
 2. information
 3. material
 4. illustration

Question ID : 264330167901

Option 1 ID : 264330658528

Option 2 ID : 264330658529

Option 3 ID : 264330658527

Option 4 ID : 264330658530

Status : Answered

Chosen Option : 2

Comprehension:

In the following passage, some words have been deleted. Read the passage carefully and select the most appropriate option to fill in each blank.

(1)_____, there are numerous products available for customers to select from, whether they are using a physical store or (2)_____ online shopping platform. Almost every product or brand has (3)_____ own USP, packaging, colour combinations and more as marketing tactics, which it uses to market itself to the customers in a (4)_____ manner. Brands find it (5)_____ challenging to engage consumers as their attention spans are dwindling at an accelerated rate.

SubQuestion No : 71**Q.71 Select the most appropriate option to fill in blank number 1.**

- Ans 1. Today
 2. Long ago
 3. Yesterday
 4. In future

Question ID : 264330167944

Option 1 ID : 264330658671

Option 2 ID : 264330658673

Option 3 ID : 264330658672

Option 4 ID : 264330658674

Status : Answered

Chosen Option : 1

Comprehension:

In the following passage, some words have been deleted. Read the passage carefully and select the most appropriate option to fill in each blank.

(1)_____, there are numerous products available for customers to select from, whether they are using a physical store or (2)_____ online shopping platform. Almost every product or brand has (3)_____ own USP, packaging, colour combinations and more as marketing tactics, which it uses to market itself to the customers in a (4)_____ manner. Brands find it (5)_____ challenging to engage consumers as their attention spans are dwindling at an accelerated rate.

SubQuestion No : 72**Q.72 Select the most appropriate option to fill in blank number 2.**

- Ans 1. a
 2. an
 3. the
 4. in

Question ID : 264330167945

Option 1 ID : 264330658676

Option 2 ID : 264330658675

Option 3 ID : 264330658677

Option 4 ID : 264330658678

Status : Answered

Chosen Option : 2

Comprehension:

In the following passage, some words have been deleted. Read the passage carefully and select the most appropriate option to fill in each blank.

(1)_____, there are numerous products available for customers to select from, whether they are using a physical store or (2)_____ online shopping platform. Almost every product or brand has (3)_____ own USP, packaging, colour combinations and more as marketing tactics, which it uses to market itself to the customers in a (4)_____ manner. Brands find it (5)_____ challenging to engage consumers as their attention spans are dwindling at an accelerated rate.

SubQuestion No : 73**Q.73 Select the most appropriate option to fill in blank number 3.**

- Ans 1. their
 2. there
 3. it's
 4. its

Question ID : 264330167946

Option 1 ID : 264330658679

Option 2 ID : 264330658680

Option 3 ID : 264330658682

Option 4 ID : 264330658681

Status : Answered

Chosen Option : 4

Comprehension:

In the following passage, some words have been deleted. Read the passage carefully and select the most appropriate option to fill in each blank.

(1)_____, there are numerous products available for customers to select from, whether they are using a physical store or (2)_____ online shopping platform. Almost every product or brand has (3)_____ own USP, packaging, colour combinations and more as marketing tactics, which it uses to market itself to the customers in a (4)_____ manner. Brands find it (5)_____ challenging to engage consumers as their attention spans are dwindling at an accelerated rate.

SubQuestion No : 74**Q.74 Select the most appropriate option to fill in blank number 4.**

- Ans 1. minute
 2. strangely
 3. unique
 4. silent

Question ID : 264330167947

Option 1 ID : 264330658686

Option 2 ID : 264330658683

Option 3 ID : 264330658685

Option 4 ID : 264330658684

Status : Answered

Chosen Option : 3

Comprehension:

In the following passage, some words have been deleted. Read the passage carefully and select the most appropriate option to fill in each blank.

(1)_____, there are numerous products available for customers to select from, whether they are using a physical store or (2)_____ online shopping platform. Almost every product or brand has (3)_____ own USP, packaging, colour combinations and more as marketing tactics, which it uses to market itself to the customers in a (4)_____ manner. Brands find it (5)_____ challenging to engage consumers as their attention spans are dwindling at an accelerated rate.

SubQuestion No : 75**Q.75 Select the most appropriate option to fill in blank number 5.**

- Ans 1. increasing
 2. increase
 3. increased
 4. increasingly

Question ID : 264330167948

Option 1 ID : 264330658689

Option 2 ID : 264330658687

Option 3 ID : 264330658688

Option 4 ID : 264330658690

Status : Answered

Chosen Option : 1

Comprehension:

In the following passage, some words have been deleted. Read the passage carefully and select the most appropriate option to fill in each blank.

Many years ago, when the art of stunting plants was quite unheard of 1._____ in remote areas of India, Buddhist monks in isolated monasteries in Tibet stunted trees like the oak, orange tree, peepal tree, etc, watching with 2._____ the tree still flowering and 3._____ fruit regardless of this 'deformity'. Since the trees looked so artistically 4._____, the art was learnt by some Chinese monks who taught 'Bonsai' making, an art that became most sought 5._____ in China.

SubQuestion No : 76**Q.76 Select the most appropriate option to fill in blank number 1.**

- Ans 1. always
 2. except
 3. excerpt
 4. expect

Question ID : 264330168259

Option 1 ID : 264330659903

Option 2 ID : 264330659904

Option 3 ID : 264330659906

Option 4 ID : 264330659905

Status : Answered

Chosen Option : 2

Comprehension:

In the following passage, some words have been deleted. Read the passage carefully and select the most appropriate option to fill in each blank.

Many years ago, when the art of stunting plants was quite unheard of 1. _____ in remote areas of India, Buddhist monks in isolated monasteries in Tibet stunted trees like the oak, orange tree, peepal tree, etc, watching with 2. _____ the tree still flowering and 3. _____ fruit regardless of this 'deformity'. Since the trees looked so artistically 4. _____, the art was learnt by some Chinese monks who taught 'Bonsai' making, an art that became most sought 5. _____ in China.

SubQuestion No : 77**Q.77 Select the most appropriate option to fill in blank number 2.**

- Ans 1. excitement
 2. entertainment
 3. embarrassment
 4. encouragement

Question ID : 264330168260

Option 1 ID : 264330659907

Option 2 ID : 264330659908

Option 3 ID : 264330659910

Option 4 ID : 264330659909

Status : Answered

Chosen Option : 1

Comprehension:

In the following passage, some words have been deleted. Read the passage carefully and select the most appropriate option to fill in each blank.

Many years ago, when the art of stunting plants was quite unheard of 1. _____ in remote areas of India, Buddhist monks in isolated monasteries in Tibet stunted trees like the oak, orange tree, peepal tree, etc, watching with 2. _____ the tree still flowering and 3. _____ fruit regardless of this 'deformity'. Since the trees looked so artistically 4. _____, the art was learnt by some Chinese monks who taught 'Bonsai' making, an art that became most sought 5. _____ in China.

SubQuestion No : 78**Q.78 Select the most appropriate option to fill in blank number 3.**

- Ans 1. ending
 2. bearing
 3. losing
 4. rising

Question ID : 264330168261

Option 1 ID : 264330659913

Option 2 ID : 264330659914

Option 3 ID : 264330659912

Option 4 ID : 264330659911

Status : Answered

Chosen Option : 2

Comprehension:

In the following passage, some words have been deleted. Read the passage carefully and select the most appropriate option to fill in each blank.

Many years ago, when the art of stunting plants was quite unheard of 1. _____ in remote areas of India, Buddhist monks in isolated monasteries in Tibet stunted trees like the oak, orange tree, peepal tree, etc, watching with 2. _____ the tree still flowering and 3. _____ fruit regardless of this 'deformity'. Since the trees looked so artistically 4. _____, the art was learnt by some Chinese monks who taught 'Bonsai' making, an art that became most sought 5. _____ in China.

SubQuestion No : 79**Q.79 Select the most appropriate option to fill in blank number 4.**

- Ans 1. fruitful
 2. beautiful
 3. cheerful
 4. harmful

Question ID : 264330168262

Option 1 ID : 264330659915

Option 2 ID : 264330659917

Option 3 ID : 264330659916

Option 4 ID : 264330659918

Status : Answered

Chosen Option : 1

Comprehension:

In the following passage, some words have been deleted. Read the passage carefully and select the most appropriate option to fill in each blank.

Many years ago, when the art of stunting plants was quite unheard of 1. _____ in remote areas of India, Buddhist monks in isolated monasteries in Tibet stunted trees like the oak, orange tree, peepal tree, etc, watching with 2. _____ the tree still flowering and 3. _____ fruit regardless of this 'deformity'. Since the trees looked so artistically 4. _____, the art was learnt by some Chinese monks who taught 'Bonsai' making, an art that became most sought 5. _____ in China.

SubQuestion No : 80**Q.80 Select the most appropriate option to fill in blank number 5.**

- Ans 1. for
 2. after
 3. with
 4. about

Question ID : 264330168263

Option 1 ID : 264330659920

Option 2 ID : 264330659919

Option 3 ID : 264330659921

Option 4 ID : 264330659922

Status : Answered

Chosen Option : 4

Comprehension:

In the following passage, some words have been deleted. Read the passage carefully and select the most appropriate option to fill in each blank.

Trees are one of the gifts of the nature which are of great (1)_____ for all living beings and environment. They have (2)_____ benefits to living beings providing natural herbs, vegetables, fruits, wood, timber, etc. Trees are the (3)_____ of many birds and insects. They are also considered as the (4)_____ part of the atmosphere which help in reducing pollution. Conserving trees and spreading awareness to plant trees will save the atmosphere from depletion and (5)_____ survival of all forms on earth.

SubQuestion No : 81**Q.81 Select the most appropriate option to fill in blank No. 1.**

- Ans 1. importance
 2. renovation
 3. transformation
 4. revolution

Question ID : 264330169784

Option 1 ID : 264330665824

Option 2 ID : 264330665826

Option 3 ID : 264330665825

Option 4 ID : 264330665823

Status : Answered

Chosen Option : 1

Comprehension:

In the following passage, some words have been deleted. Read the passage carefully and select the most appropriate option to fill in each blank.

Trees are one of the gifts of the nature which are of great (1)_____ for all living beings and environment. They have (2)_____ benefits to living beings providing natural herbs, vegetables, fruits, wood, timber, etc. Trees are the (3)_____ of many birds and insects. They are also considered as the (4)_____ part of the atmosphere which help in reducing pollution. Conserving trees and spreading awareness to plant trees will save the atmosphere from depletion and (5)_____ survival of all forms on earth.

SubQuestion No : 82**Q.82 Select the most appropriate option to fill in blank No. 2.**

- Ans 1. less
 2. minor
 3. ample
 4. acute

Question ID : 264330169785

Option 1 ID : 264330665827

Option 2 ID : 264330665830

Option 3 ID : 264330665829

Option 4 ID : 264330665828

Status : Answered

Chosen Option : 3

Comprehension:

In the following passage, some words have been deleted. Read the passage carefully and select the most appropriate option to fill in each blank.

Trees are one of the gifts of the nature which are of great (1)_____ for all living beings and environment. They have (2)_____ benefits to living beings providing natural herbs, vegetables, fruits, wood, timber, etc. Trees are the (3)_____ of many birds and insects. They are also considered as the (4)_____ part of the atmosphere which help in reducing pollution. Conserving trees and spreading awareness to plant trees will save the atmosphere from depletion and (5)_____ survival of all forms on earth.

SubQuestion No : 83**Q.83 Select the most appropriate option to fill in blank No. 3.**

- Ans 1. abode
 2. refuge
 3. terrain
 4. asylum

Question ID : 264330169786

Option 1 ID : 264330665832

Option 2 ID : 264330665831

Option 3 ID : 264330665834

Option 4 ID : 264330665833

Status : Answered

Chosen Option : 1

Comprehension:

In the following passage, some words have been deleted. Read the passage carefully and select the most appropriate option to fill in each blank.

Trees are one of the gifts of the nature which are of great (1)_____ for all living beings and environment. They have (2)_____ benefits to living beings providing natural herbs, vegetables, fruits, wood, timber, etc. Trees are the (3)_____ of many birds and insects. They are also considered as the (4)_____ part of the atmosphere which help in reducing pollution. Conserving trees and spreading awareness to plant trees will save the atmosphere from depletion and (5)_____ survival of all forms on earth.

SubQuestion No : 84**Q.84 Select the most appropriate option to fill in blank No. 4.**

- Ans 1. superficial
 2. trivial
 3. petty
 4. integral

Question ID : 264330169787

Option 1 ID : 264330665838

Option 2 ID : 264330665835

Option 3 ID : 264330665837

Option 4 ID : 264330665836

Status : Answered

Chosen Option : 4

Comprehension:

In the following passage, some words have been deleted. Read the passage carefully and select the most appropriate option to fill in each blank.

Trees are one of the gifts of the nature which are of great (1)_____ for all living beings and environment. They have (2)_____ benefits to living beings providing natural herbs, vegetables, fruits, wood, timber, etc. Trees are the (3)_____ of many birds and insects. They are also considered as the (4)_____ part of the atmosphere which help in reducing pollution. Conserving trees and spreading awareness to plant trees will save the atmosphere from depletion and (5)_____ survival of all forms on earth.

SubQuestion No : 85

Q.85 Select the most appropriate option to fill in blank No. 5.

- Ans 1. rebuke
 2. refuse
 3. ensure
 4. pretend

Question ID : 264330169788

Option 1 ID : 264330665841

Option 2 ID : 264330665839

Option 3 ID : 264330665840

Option 4 ID : 264330665842

Status : Answered

Chosen Option : 3

Comprehension:

Read the given passage and answer the questions that follow.

An important skill we all need to learn, in my opinion, is not to have preconceived notions about anything. Having said that I also know how difficult a thing it can be!

To drop the burden of preconceived notions, we need to unlearn a few things, which again is a tough thing to do. Very early on, we start cramming our brains with ideas and opinions.

These notions might have entered our mind from our family, parents, society or some of the books we might have read. We need to understand the fact that everything in life keeps changing and we just cannot stick to something only because that thought might have entered our brains years back!

I always thought ice-creams or chilled items were bad for a child having a cold or a running nose. I was terribly surprised when a GP in London told my four-year-old grandson with a cold to go ahead and have a popsicle. Later I found out that there is no scientific evidence to prove that an ice-cream or a popsicle can aggravate a cold!

SubQuestion No : 86

Q.86 Select the statement that is correct according to the passage.

- Ans 1. Unlearning preconceived notions is an effortless process.
 2. Scientific research has proven that ice-creams worsen cold symptoms.
 3. Unlearning preconceived notions is a tough thing to do.
 4. The author's grandson was advised to consume ice-creams to treat his cold.

Question ID : 264330170219

Option 1 ID : 264330667550

Option 2 ID : 264330667547

Option 3 ID : 264330667549

Option 4 ID : 264330667548

Status : Answered

Chosen Option : 3

Comprehension:

Read the given passage and answer the questions that follow.

An important skill we all need to learn, in my opinion, is not to have preconceived notions about anything. Having said that I also know how difficult a thing it can be!

To drop the burden of preconceived notions, we need to unlearn a few things, which again is a tough thing to do. Very early on, we start cramming our brains with ideas and opinions.

These notions might have entered our mind from our family, parents, society or some of the books we might have read. We need to understand the fact that everything in life keeps changing and we just cannot stick to something only because that thought might have entered our brains years back!

I always thought ice-creams or chilled items were bad for a child having a cold or a running nose. I was terribly surprised when a GP in London told my four-year-old grandson with a cold to go ahead and have a popsicle. Later I found out that there is no scientific evidence to prove that an ice-cream or a popsicle can aggravate a cold!

SubQuestion No : 87

Q.87 Select the most appropriate ANTONYM of the given word used in the passage.

Aggravate

- Ans 1. Alleviate
 2. Pester
 3. Destroy
 4. Annihilate

Question ID : 264330170218

Option 1 ID : 264330667546

Option 2 ID : 264330667545

Option 3 ID : 264330667543

Option 4 ID : 264330667544

Status : Answered

Chosen Option : 1

Comprehension:

Read the given passage and answer the questions that follow.

An important skill we all need to learn, in my opinion, is not to have preconceived notions about anything. Having said that I also know how difficult a thing it can be!

To drop the burden of preconceived notions, we need to unlearn a few things, which again is a tough thing to do. Very early on, we start cramming our brains with ideas and opinions.

These notions might have entered our mind from our family, parents, society or some of the books we might have read. We need to understand the fact that everything in life keeps changing and we just cannot stick to something only because that thought might have entered our brains years back!

I always thought ice-creams or chilled items were bad for a child having a cold or a running nose. I was terribly surprised when a GP in London told my four-year-old grandson with a cold to go ahead and have a popsicle. Later I found out that there is no scientific evidence to prove that an ice-cream or a popsicle can aggravate a cold!

SubQuestion No : 88

Q.88 Select the most appropriate theme of the passage.

- Ans 1. The role of scientific evidence in debunking misconceptions
 2. The significance of seeking professional advice
 3. The need for evidence-based decision making
 4. The influence of personal experiences on our beliefs

Question ID : 264330170220

Option 1 ID : 264330667551

Option 2 ID : 264330667553

Option 3 ID : 264330667554

Option 4 ID : 264330667552

Status : Answered

Chosen Option : 1

Comprehension:

Read the given passage and answer the questions that follow.

An important skill we all need to learn, in my opinion, is not to have preconceived notions about anything. Having said that I also know how difficult a thing it can be!

To drop the burden of preconceived notions, we need to unlearn a few things, which again is a tough thing to do. Very early on, we start cramming our brains with ideas and opinions.

These notions might have entered our mind from our family, parents, society or some of the books we might have read. We need to understand the fact that everything in life keeps changing and we just cannot stick to something only because that thought might have entered our brains years back!

I always thought ice-creams or chilled items were bad for a child having a cold or a running nose. I was terribly surprised when a GP in London told my four-year-old grandson with a cold to go ahead and have a popsicle. Later I found out that there is no scientific evidence to prove that an ice-cream or a popsicle can aggravate a cold!

SubQuestion No : 89

Q.89 Select the most appropriate title for the given passage.

- Ans 1. Challenging the Thought Process
2. Unlearning Preconceived Notions
3. Evaluating Our Superstitions
4. The Power of Our Mind

Question ID : 264330170216

Option 1 ID : 264330667538

Option 2 ID : 264330667535

Option 3 ID : 264330667536

Option 4 ID : 264330667537

Status : Answered

Chosen Option : 2

Comprehension:

Read the given passage and answer the questions that follow.

An important skill we all need to learn, in my opinion, is not to have preconceived notions about anything. Having said that I also know how difficult a thing it can be!

To drop the burden of preconceived notions, we need to unlearn a few things, which again is a tough thing to do. Very early on, we start cramming our brains with ideas and opinions.

These notions might have entered our mind from our family, parents, society or some of the books we might have read. We need to understand the fact that everything in life keeps changing and we just cannot stick to something only because that thought might have entered our brains years back!

I always thought ice-creams or chilled items were bad for a child having a cold or a running nose. I was terribly surprised when a GP in London told my four-year-old grandson with a cold to go ahead and have a popsicle. Later I found out that there is no scientific evidence to prove that an ice-cream or a popsicle can aggravate a cold!

SubQuestion No : 90

Q.90 What is the tone of the passage?

- Ans 1. Humorous
2. Reflective
3. Humanistic
4. Sarcastic

Question ID : 264330170217

Option 1 ID : 264330667542

Option 2 ID : 264330667540

Option 3 ID : 264330667539

Option 4 ID : 264330667541

Status : Answered

Chosen Option : 2

Comprehension:

Read the given passage and answer the questions that follow.

The term 'personalised learning' has been in vogue for a long time. Earlier, it referred to a one-to-one tutoring system, mostly for the privileged. Today, it refers to learning that prioritises an individual student's requirements and uses flexible instructional practices in terms of content, pace and materials. Learning need not be linear as, sometimes, learners may have to take a step back if not equipped with the necessary schemata to understand the content. The entire learning process becomes student-centric and the students are encouraged to design their own learning pathways.

Artificial Intelligence (AI) and Data Analytics play a major role in online and hybrid learning platforms. Globally, HEIs are introducing programmes where AI provides the platform to launch personalised learning. Technology provides a variety of materials in various formats to suit different students and monitor and assess their progress. However, it does not undermine the teacher's role. There are areas such as communication and collaborative skills, and emotional intelligence, which require human intervention. Therefore, the role of teachers in personalised learning remains as important as it is in traditional learning. AI can never replace educators; it can only enhance and support personalised learning by providing automated tasks, assessment platforms and feedback.

Many paths of study emerge and all ultimately merge with the curriculum's common learning outcome. Thus, the pattern of education becomes student-centric. This systemic change gives a new dimension to the teaching-learning process where teaching becomes counseling, and the teacher becomes a mentor. The students are motivated to take control of their learning and become autonomous.

SubQuestion No : 91

Q.91 Select an appropriate title for the given passage.

- Ans 1. Technology Formats to Assess Students' Intellect
2. Student-Centric Pedagogy Fosters Learner Autonomy
3. Personalised Learning Aims at Teachers' Strength
4. The Latest Trends of Content

Question ID : 264330169184

Option 1 ID : 264330663530

Option 2 ID : 264330663528

Option 3 ID : 264330663529

Option 4 ID : 264330663527

Status : Answered

Chosen Option : 1

Comprehension:

Read the given passage and answer the questions that follow.

The term 'personalised learning' has been in vogue for a long time. Earlier, it referred to a one-to-one tutoring system, mostly for the privileged. Today, it refers to learning that prioritises an individual student's requirements and uses flexible instructional practices in terms of content, pace and materials. Learning need not be linear as, sometimes, learners may have to take a step back if not equipped with the necessary schemata to understand the content. The entire learning process becomes student-centric and the students are encouraged to design their own learning pathways.

Artificial Intelligence (AI) and Data Analytics play a major role in online and hybrid learning platforms. Globally, HEIs are introducing programmes where AI provides the platform to launch personalised learning. Technology provides a variety of materials in various formats to suit different students and monitor and assess their progress. However, it does not undermine the teacher's role. There are areas such as communication and collaborative skills, and emotional intelligence, which require human intervention. Therefore, the role of teachers in personalised learning remains as important as it is in traditional learning. AI can never replace educators; it can only enhance and support personalised learning by providing automated tasks, assessment platforms and feedback.

Many paths of study emerge and all ultimately merge with the curriculum's common learning outcome. Thus, the pattern of education becomes student-centric. This systemic change gives a new dimension to the teaching-learning process where teaching becomes counseling, and the teacher becomes a mentor. The students are motivated to take control of their learning and become autonomous.

SubQuestion No : 92

Q.92 The most appropriate synonym of the word 'linear' is:

- Ans 1. rapid
 2. continuous
 3. variable
 4. ambiguous

Question ID : 264330169187

Option 1 ID : 264330663539

Option 2 ID : 264330663542

Option 3 ID : 264330663541

Option 4 ID : 264330663540

Status : Answered

Chosen Option : 3

Comprehension:

Read the given passage and answer the questions that follow.

The term 'personalised learning' has been in vogue for a long time. Earlier, it referred to a one-to-one tutoring system, mostly for the privileged. Today, it refers to learning that prioritises an individual student's requirements and uses flexible instructional practices in terms of content, pace and materials. Learning need not be linear as, sometimes, learners may have to take a step back if not equipped with the necessary schemata to understand the content. The entire learning process becomes student-centric and the students are encouraged to design their own learning pathways.

Artificial Intelligence (AI) and Data Analytics play a major role in online and hybrid learning platforms. Globally, HEIs are introducing programmes where AI provides the platform to launch personalised learning. Technology provides a variety of materials in various formats to suit different students and monitor and assess their progress. However, it does not undermine the teacher's role. There are areas such as communication and collaborative skills, and emotional intelligence, which require human intervention. Therefore, the role of teachers in personalised learning remains as important as it is in traditional learning. AI can never replace educators; it can only enhance and support personalised learning by providing automated tasks, assessment platforms and feedback.

Many paths of study emerge and all ultimately merge with the curriculum's common learning outcome. Thus, the pattern of education becomes student-centric. This systemic change gives a new dimension to the teaching-learning process where teaching becomes counseling, and the teacher becomes a mentor. The students are motivated to take control of their learning and become autonomous.

SubQuestion No : 93

Q.93 The passage supports which of the following statements?

- Ans 1. Artificial Intelligence and Data Analytics enhance assessment platforms.
2. The role of teachers in personalised learning remains the same as in traditional learning.
3. The pattern of education has become teacher-centric today.
4. Flexible instructional practices prioritise the learning objectives of the curriculum.

Question ID : 264330169185

Option 1 ID : 264330663534

Option 2 ID : 264330663533

Option 3 ID : 264330663532

Option 4 ID : 264330663531

Status : Answered

Chosen Option : 2

Comprehension:

Read the given passage and answer the questions that follow.

The term 'personalised learning' has been in vogue for a long time. Earlier, it referred to a one-to-one tutoring system, mostly for the privileged. Today, it refers to learning that prioritises an individual student's requirements and uses flexible instructional practices in terms of content, pace and materials. Learning need not be linear as, sometimes, learners may have to take a step back if not equipped with the necessary schemata to understand the content. The entire learning process becomes student-centric and the students are encouraged to design their own learning pathways.

Artificial Intelligence (AI) and Data Analytics play a major role in online and hybrid learning platforms. Globally, HEIs are introducing programmes where AI provides the platform to launch personalised learning. Technology provides a variety of materials in various formats to suit different students and monitor and assess their progress. However, it does not undermine the teacher's role. There are areas such as communication and collaborative skills, and emotional intelligence, which require human intervention. Therefore, the role of teachers in personalised learning remains as important as it is in traditional learning. AI can never replace educators; it can only enhance and support personalised learning by providing automated tasks, assessment platforms and feedback.

Many paths of study emerge and all ultimately merge with the curriculum's common learning outcome. Thus, the pattern of education becomes student-centric. This systemic change gives a new dimension to the teaching-learning process where teaching becomes counseling, and the teacher becomes a mentor. The students are motivated to take control of their learning and become autonomous.

SubQuestion No : 94

Q.94 What is the tone of the given passage?

Ans 1. Supportive and encouraging

2. Outraged and angry

3. Sorrowful and sympathetic

4. Humorous and amusing

Question ID : 264330169188

Option 1 ID : 264330663544

Option 2 ID : 264330663545

Option 3 ID : 264330663543

Option 4 ID : 264330663546

Status : Answered

Chosen Option : 1

Comprehension:

Read the given passage and answer the questions that follow.

The term 'personalised learning' has been in vogue for a long time. Earlier, it referred to a one-to-one tutoring system, mostly for the privileged. Today, it refers to learning that prioritises an individual student's requirements and uses flexible instructional practices in terms of content, pace and materials. Learning need not be linear as, sometimes, learners may have to take a step back if not equipped with the necessary schemata to understand the content. The entire learning process becomes student-centric and the students are encouraged to design their own learning pathways.

Artificial Intelligence (AI) and Data Analytics play a major role in online and hybrid learning platforms. Globally, HEIs are introducing programmes where AI provides the platform to launch personalised learning. Technology provides a variety of materials in various formats to suit different students and monitor and assess their progress. However, it does not undermine the teacher's role. There are areas such as communication and collaborative skills, and emotional intelligence, which require human intervention. Therefore, the role of teachers in personalised learning remains as important as it is in traditional learning. AI can never replace educators; it can only enhance and support personalised learning by providing automated tasks, assessment platforms and feedback.

Many paths of study emerge and all ultimately merge with the curriculum's common learning outcome. Thus, the pattern of education becomes student-centric. This systemic change gives a new dimension to the teaching-learning process where teaching becomes counseling, and the teacher becomes a mentor. The students are motivated to take control of their learning and become autonomous.

SubQuestion No : 95

Q.95 What is the best summary of the given passage?

- Ans
- 1. The role of teachers in personalised learning does not remain as important as it is in traditional learning.
 - 2. Student-centric learning engages students as a facilitator in their own learning.
 - 3. Personalised learning is tailored to the individual needs of each student.
 - 4. Artificial Intelligence includes mimicking human cognitive activity and giving freedom to the students to study in a way that suits them partially.

Question ID : 264330169186

Option 1 ID : 264330663538

Option 2 ID : 264330663537

Option 3 ID : 264330663535

Option 4 ID : 264330663536

Status : Answered

Chosen Option : 2

Comprehension:

Read the given passage and answer the questions that follow.

Emma had always been a driven and ambitious student. She had a passion for science and medicine, and her dream was to become a doctor. She worked tirelessly throughout her college years, studying long hours and sacrificing her social life in pursuit of her goals. Despite the challenges, Emma was determined to succeed and make a difference in the world.

One fateful evening, while driving home from a late-night study session, Emma's life changed forever. A car came out of nowhere and collided with her vehicle, sending it spinning out of control. When the dust settled, Emma found herself trapped inside the wreckage, unable to move or even scream for help. The accident had left her with a broken leg and several other injuries. Emma was in shock and couldn't believe what had happened to her. She was devastated to think that all her hard work and dedication had been for nothing. She would now have to put her dreams on hold and spend months recovering from her injuries.

As Emma lay in the hospital, she was consumed with anger and frustration. She couldn't understand why this had happened to her, why her life had been turned upside down in an instant. She felt alone and helpless, unable to find any sense of purpose or meaning in her suffering. But as the days turned into weeks, Emma began to notice something different about the people around her. She met a nurse named Mary, who had been working at the hospital for over twenty years. Mary had a kind and caring personality, which Emma found comforting during her stay. She also met a patient named John, who had been in a car accident similar to Emma's. John had suffered a spinal cord injury and was paralysed from the waist down. Despite his condition, John was always positive and never gave up hope.

Emma soon realised that the accident had brought her into contact with these amazing people and had given her the opportunity to learn from them. She learned from Mary how to be kind and caring towards others, even in difficult situations. She learned from John how to be positive and never give up, even when things seem impossible. After several months of recovery, Emma was able to walk again, but she still faced many challenges. She had to work extra hard to catch up with her studies and she had to adjust to life with a permanent scar on her leg. However, she realised that the accident had taught her valuable lessons that would help her become a better doctor. She had learned to empathise with her patients and to be grateful for her own health.

Years later, Emma became a successful doctor and was known for her compassion and empathy towards her patients. She often thought back to the accident and realised that it had been a turning point in her life. It had forced her to slow down and appreciate the small things in life. She was grateful for the people she had met during her recovery and realised that without the accident, she may never have met them. This story reflects that whatever happens, it happens for good. Even though the accident had seemed like a setback for Emma, it had brought her into contact with amazing people and taught her valuable lessons that she would carry with her for the rest of her life. Sometimes, the things we think are obstacles are actually opportunities in disguise. It is up to us to find the silver lining and make the best of every situation.

SubQuestion No : 96

Q.96 Find the ANTONYM of the word 'aggravate' from the passage.

- Ans 1. Tease
 2. Oblige
 3. Dedicate
 4. Irritate

Question ID : 264330168881

Option 1 ID : 264330662333

Option 2 ID : 264330662332

Option 3 ID : 264330662334

Option 4 ID : 264330662331

Status : Answered

Chosen Option : 2

Comprehension:

Read the given passage and answer the questions that follow.

Emma had always been a driven and ambitious student. She had a passion for science and medicine, and her dream was to become a doctor. She worked tirelessly throughout her college years, studying long hours and sacrificing her social life in pursuit of her goals. Despite the challenges, Emma was determined to succeed and make a difference in the world.

One fateful evening, while driving home from a late-night study session, Emma's life changed forever. A car came out of nowhere and collided with her vehicle, sending it spinning out of control. When the dust settled, Emma found herself trapped inside the wreckage, unable to move or even scream for help. The accident had left her with a broken leg and several other injuries. Emma was in shock and couldn't believe what had happened to her. She was devastated to think that all her hard work and dedication had been for nothing. She would now have to put her dreams on hold and spend months recovering from her injuries.

As Emma lay in the hospital, she was consumed with anger and frustration. She couldn't understand why this had happened to her, why her life had been turned upside down in an instant. She felt alone and helpless, unable to find any sense of purpose or meaning in her suffering. But as the days turned into weeks, Emma began to notice something different about the people around her. She met a nurse named Mary, who had been working at the hospital for over twenty years. Mary had a kind and caring personality, which Emma found comforting during her stay. She also met a patient named John, who had been in a car accident similar to Emma's. John had suffered a spinal cord injury and was paralysed from the waist down. Despite his condition, John was always positive and never gave up hope.

Emma soon realised that the accident had brought her into contact with these amazing people and had given her the opportunity to learn from them. She learned from Mary how to be kind and caring towards others, even in difficult situations. She learned from John how to be positive and never give up, even when things seem impossible. After several months of recovery, Emma was able to walk again, but she still faced many challenges. She had to work extra hard to catch up with her studies and she had to adjust to life with a permanent scar on her leg. However, she realised that the accident had taught her valuable lessons that would help her become a better doctor. She had learned to empathise with her patients and to be grateful for her own health.

Years later, Emma became a successful doctor and was known for her compassion and empathy towards her patients. She often thought back to the accident and realised that it had been a turning point in her life. It had forced her to slow down and appreciate the small things in life. She was grateful for the people she had met during her recovery and realised that without the accident, she may never have met them. This story reflects that whatever happens, it happens for good. Even though the accident had seemed like a setback for Emma, it had brought her into contact with amazing people and taught her valuable lessons that she would carry with her for the rest of her life. Sometimes, the things we think are obstacles are actually opportunities in disguise. It is up to us to find the silver lining and make the best of every situation.

SubQuestion No : 97

Q.97 What was Emma's dream before the accident?

- Ans
- 1. To become a nurse
 - 2. To become a lawyer
 - 3. To become a teacher
 - 4. To become a doctor

Question ID : 264330168877

Option 1 ID : 264330662315

Option 2 ID : 264330662318

Option 3 ID : 264330662317

Option 4 ID : 264330662316

Status : Answered

Chosen Option : 4

Comprehension:

Read the given passage and answer the questions that follow.

Emma had always been a driven and ambitious student. She had a passion for science and medicine, and her dream was to become a doctor. She worked tirelessly throughout her college years, studying long hours and sacrificing her social life in pursuit of her goals. Despite the challenges, Emma was determined to succeed and make a difference in the world.

One fateful evening, while driving home from a late-night study session, Emma's life changed forever. A car came out of nowhere and collided with her vehicle, sending it spinning out of control. When the dust settled, Emma found herself trapped inside the wreckage, unable to move or even scream for help. The accident had left her with a broken leg and several other injuries. Emma was in shock and couldn't believe what had happened to her. She was devastated to think that all her hard work and dedication had been for nothing. She would now have to put her dreams on hold and spend months recovering from her injuries.

As Emma lay in the hospital, she was consumed with anger and frustration. She couldn't understand why this had happened to her, why her life had been turned upside down in an instant. She felt alone and helpless, unable to find any sense of purpose or meaning in her suffering. But as the days turned into weeks, Emma began to notice something different about the people around her. She met a nurse named Mary, who had been working at the hospital for over twenty years. Mary had a kind and caring personality, which Emma found comforting during her stay. She also met a patient named John, who had been in a car accident similar to Emma's. John had suffered a spinal cord injury and was paralysed from the waist down. Despite his condition, John was always positive and never gave up hope.

Emma soon realised that the accident had brought her into contact with these amazing people and had given her the opportunity to learn from them. She learned from Mary how to be kind and caring towards others, even in difficult situations. She learned from John how to be positive and never give up, even when things seem impossible. After several months of recovery, Emma was able to walk again, but she still faced many challenges. She had to work extra hard to catch up with her studies and she had to adjust to life with a permanent scar on her leg. However, she realised that the accident had taught her valuable lessons that would help her become a better doctor. She had learned to empathise with her patients and to be grateful for her own health.

Years later, Emma became a successful doctor and was known for her compassion and empathy towards her patients. She often thought back to the accident and realised that it had been a turning point in her life. It had forced her to slow down and appreciate the small things in life. She was grateful for the people she had met during her recovery and realised that without the accident, she may never have met them. This story reflects that whatever happens, it happens for good. Even though the accident had seemed like a setback for Emma, it had brought her into contact with amazing people and taught her valuable lessons that she would carry with her for the rest of her life. Sometimes, the things we think are obstacles are actually opportunities in disguise. It is up to us to find the silver lining and make the best of every situation.

SubQuestion No : 98

Q.98 What is the significance of the patient John in the story?

- Ans
- 1. He is a fellow colleague of Emma's who is also recovering from an injury
 - 2. He teaches Emma how to be kind and caring towards others, even in difficult situations
 - 3. He is a doctor who specialises in spinal cord injuries and helps Emma learn about the medical field
 - 4. He helps Emma recover from her injuries and shows her how to be positive and never give up

Question ID : 264330168880

Option 1 ID : 264330662329

Option 2 ID : 264330662327

Option 3 ID : 264330662330

Option 4 ID : 264330662328

Status : Answered

Chosen Option : 4

Comprehension:

Read the given passage and answer the questions that follow.

Emma had always been a driven and ambitious student. She had a passion for science and medicine, and her dream was to become a doctor. She worked tirelessly throughout her college years, studying long hours and sacrificing her social life in pursuit of her goals. Despite the challenges, Emma was determined to succeed and make a difference in the world.

One fateful evening, while driving home from a late-night study session, Emma's life changed forever. A car came out of nowhere and collided with her vehicle, sending it spinning out of control. When the dust settled, Emma found herself trapped inside the wreckage, unable to move or even scream for help. The accident had left her with a broken leg and several other injuries. Emma was in shock and couldn't believe what had happened to her. She was devastated to think that all her hard work and dedication had been for nothing. She would now have to put her dreams on hold and spend months recovering from her injuries.

As Emma lay in the hospital, she was consumed with anger and frustration. She couldn't understand why this had happened to her, why her life had been turned upside down in an instant. She felt alone and helpless, unable to find any sense of purpose or meaning in her suffering. But as the days turned into weeks, Emma began to notice something different about the people around her. She met a nurse named Mary, who had been working at the hospital for over twenty years. Mary had a kind and caring personality, which Emma found comforting during her stay. She also met a patient named John, who had been in a car accident similar to Emma's. John had suffered a spinal cord injury and was paralysed from the waist down. Despite his condition, John was always positive and never gave up hope.

Emma soon realised that the accident had brought her into contact with these amazing people and had given her the opportunity to learn from them. She learned from Mary how to be kind and caring towards others, even in difficult situations. She learned from John how to be positive and never give up, even when things seem impossible. After several months of recovery, Emma was able to walk again, but she still faced many challenges. She had to work extra hard to catch up with her studies and she had to adjust to life with a permanent scar on her leg. However, she realised that the accident had taught her valuable lessons that would help her become a better doctor. She had learned to empathise with her patients and to be grateful for her own health.

Years later, Emma became a successful doctor and was known for her compassion and empathy towards her patients. She often thought back to the accident and realised that it had been a turning point in her life. It had forced her to slow down and appreciate the small things in life. She was grateful for the people she had met during her recovery and realised that without the accident, she may never have met them. This story reflects that whatever happens, it happens for good. Even though the accident had seemed like a setback for Emma, it had brought her into contact with amazing people and taught her valuable lessons that she would carry with her for the rest of her life. Sometimes, the things we think are obstacles are actually opportunities in disguise. It is up to us to find the silver lining and make the best of every situation.

SubQuestion No : 99

Q.99 What challenges did Emma face after her recovery?

- Ans
- 1. She had to adjust to life with a permanent scar on her back.
 - 2. She had to adjust to life with a permanent scar on her face.
 - 3. She had to adjust to life with a permanent scar on her leg.
 - 4. She had to adjust to life with a permanent scar on her arm.

Question ID : 264330168878

Option 1 ID : 264330662322

Option 2 ID : 264330662321

Option 3 ID : 264330662319

Option 4 ID : 264330662320

Status : Answered

Chosen Option : 3

Comprehension:

Read the given passage and answer the questions that follow.

Emma had always been a driven and ambitious student. She had a passion for science and medicine, and her dream was to become a doctor. She worked tirelessly throughout her college years, studying long hours and sacrificing her social life in pursuit of her goals. Despite the challenges, Emma was determined to succeed and make a difference in the world.

One fateful evening, while driving home from a late-night study session, Emma's life changed forever. A car came out of nowhere and collided with her vehicle, sending it spinning out of control. When the dust settled, Emma found herself trapped inside the wreckage, unable to move or even scream for help. The accident had left her with a broken leg and several other injuries. Emma was in shock and couldn't believe what had happened to her. She was devastated to think that all her hard work and dedication had been for nothing. She would now have to put her dreams on hold and spend months recovering from her injuries.

As Emma lay in the hospital, she was consumed with anger and frustration. She couldn't understand why this had happened to her, why her life had been turned upside down in an instant. She felt alone and helpless, unable to find any sense of purpose or meaning in her suffering. But as the days turned into weeks, Emma began to notice something different about the people around her. She met a nurse named Mary, who had been working at the hospital for over twenty years. Mary had a kind and caring personality, which Emma found comforting during her stay. She also met a patient named John, who had been in a car accident similar to Emma's. John had suffered a spinal cord injury and was paralysed from the waist down. Despite his condition, John was always positive and never gave up hope.

Emma soon realised that the accident had brought her into contact with these amazing people and had given her the opportunity to learn from them. She learned from Mary how to be kind and caring towards others, even in difficult situations. She learned from John how to be positive and never give up, even when things seem impossible. After several months of recovery, Emma was able to walk again, but she still faced many challenges. She had to work extra hard to catch up with her studies and she had to adjust to life with a permanent scar on her leg. However, she realised that the accident had taught her valuable lessons that would help her become a better doctor. She had learned to empathise with her patients and to be grateful for her own health.

Years later, Emma became a successful doctor and was known for her compassion and empathy towards her patients. She often thought back to the accident and realised that it had been a turning point in her life. It had forced her to slow down and appreciate the small things in life. She was grateful for the people she had met during her recovery and realised that without the accident, she may never have met them. This story reflects that whatever happens, it happens for good. Even though the accident had seemed like a setback for Emma, it had brought her into contact with amazing people and taught her valuable lessons that she would carry with her for the rest of her life. Sometimes, the things we think are obstacles are actually opportunities in disguise. It is up to us to find the silver lining and make the best of every situation.

SubQuestion No : 100

Q.100 What is the central theme of the story?

- Ans
- 1. The importance of staying positive in difficult situations
 - 2. The value of hard work and dedication in achieving one's dreams
 - 3. The idea that obstacles can present unexpected opportunities
 - 4. The challenges of recovering from a serious injury

Question ID : 264330168879

Option 1 ID : 264330662323

Option 2 ID : 264330662325

Option 3 ID : 264330662326

Option 4 ID : 264330662324

Status : Answered

Chosen Option : 1

Stenographer Grade C and D Examination 2023

Roll Number	
Candidate Name	
Venue Name	iON Digital Zone iDZ3 Patliputra
Exam Date	13/10/2023
Exam Time	9:00 AM - 11:00 AM
Subject	Stenographer Grade C and D Examination 2023

Section : General Intelligence and Reasoning

Q.1 दो कथनों के बाद I और II अंकित करके दो कथन दिए गए हैं। उन कथनों को सही मानते हुए, भले ही वे सामान्य रूप से ज्ञात तथ्यों से भिन्न प्रतीत होते हों, यह तय करें कि कौन सा/से निष्कर्ष तार्किक रूप से उन कथनों का अनुसरण करता है/ करते हैं।

कथन:

कुछ खिड़कियाँ, दरवाजे हैं।
कोई भी खिड़की, कपबोर्ड नहीं है।

निष्कर्ष:

- I. कोई भी कपबोर्ड, दरवाजा नहीं है।
II. कुछ दरवाजे निश्चय ही कपबोर्ड नहीं हैं।

- Ans 1. केवल निष्कर्ष I अनुसरण करता है
 2. न तो निष्कर्ष I न ही II अनुसरण करता है
 3. दोनों निष्कर्ष I और II अनुसरण करते हैं
 4. केवल निष्कर्ष II अनुसरण करता है

Question ID : 264330144918
Option 1 ID : 264330567927
Option 2 ID : 264330567930
Option 3 ID : 264330567929
Option 4 ID : 264330567928
Status : Answered
Chosen Option : 2

Q.2 दी गई आकृति में कितने त्रिभुज हैं?

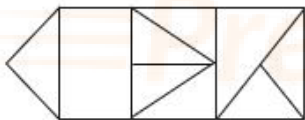

- Ans 1. 10
 2. 9
 3. 11
 4. 8

Question ID : 26433068624
Option 1 ID : 264330269011
Option 2 ID : 264330269008
Option 3 ID : 264330269010
Option 4 ID : 264330269009
Status : Answered
Chosen Option : 1

Q.3 निम्नलिखित में से कौन-सी संख्या, दी गई श्रृंखला में प्रश्नचिह्न (?) को प्रतिस्थापित करेगी?
112, 103, 94, 85, 76, ?

- Ans 1. 72
 2. 77
 3. 67
 4. 63

Question ID : 264330102152
Option 1 ID : 264330401076
Option 2 ID : 264330401073
Option 3 ID : 264330401074
Option 4 ID : 264330401075
Status : Answered
Chosen Option : 3

Q.4 यदि '-' का अर्थ '+' है, 'x' का अर्थ '+' है, '+' का अर्थ 'x' है और '+' का अर्थ '-' है, तो निम्न व्यंजक का मान क्या होगा?

$$(15 + 9 \times (4 \times 5)) - (3 \div 1) \div 2$$

- Ans 1. 10
 2. 15
 3. 20
 4. 5

Question ID : 264330144868
Option 1 ID : 264330567728
Option 2 ID : 264330567729
Option 3 ID : 264330567730
Option 4 ID : 264330567727
Status : Answered
Chosen Option : 1

Q.5 उस विकल्प का चयन कीजिए जो उन अक्षरों को निरूपित करता है, जिन्हें जब निम्न रिक्त स्थानों में क्रमिक रूप से बाएं से दाएं रखा जाएगा, तो वे अक्षर श्रृंखला को पूरा कर देंगे।
S _ _ K B _ F H _ B S F _ K _ S F _ _ B

- Ans 1. FHSKBHKK
 2. FHSKHKKK
 3. FHSKHBHK
 4. FHSKKBHK

Question ID : 26433068921
Option 1 ID : 264330270198
Option 2 ID : 264330270196
Option 3 ID : 264330270197
Option 4 ID : 264330270199
Status : Answered
Chosen Option : 3

Q.6 यदि \times का अर्थ \div है, \div का अर्थ $+$ है, $-$ का अर्थ \times है, $+$ का अर्थ $-$ है, तो निम्नलिखित समीकरण का सही उत्तर क्या होगा?
 $175 \times 25 - 5 \div 20 + 3 - 10 = ?$

- Ans 1. 20
 2. 25
 3. 30
 4. 35

Question ID : 264330130214
 Option 1 ID : 264330509967
 Option 2 ID : 264330509968
 Option 3 ID : 264330509969
 Option 4 ID : 264330509970
 Status : Answered
 Chosen Option : 2

Q.7 उस विकल्प का चयन कीजिए जो चौथी संख्या से उसी प्रकार संबंधित है जिस प्रकार पहली संख्या दूसरी संख्या से संबंधित है और पांचवीं संख्या छठी संख्या से संबंधित है?

$$216 : 3 :: ? : 4 :: 1728 : 6$$

- Ans 1. 946
 2. 512
 3. 864
 4. 728

Question ID : 264330144880
 Option 1 ID : 264330567777
 Option 2 ID : 264330567775
 Option 3 ID : 264330567778
 Option 4 ID : 264330567776
 Status : Answered
 Chosen Option : 2

Q.8 यदि $F = C < B = E$ और $D < C = A < E$ है, तो निम्नलिखित में से कौन-सा विकल्प सही नहीं है?

- Ans 1. $E > D$
 2. $A < B$
 3. $A = F$
 4. $A > E$

Question ID : 26433097272
 Option 1 ID : 264330381785
 Option 2 ID : 264330381788
 Option 3 ID : 264330381786
 Option 4 ID : 264330381787
 Status : Answered
 Chosen Option : 2

Q.9 निम्नलिखित चार अक्षर-समूहों में से तीन एक निश्चित तरीके से आपस में संगत हैं, जबकि कोई एक उनसे असंगत है। असंगत अक्षर-समूह का चयन करें।

- Ans 1. RTIG
 2. TVGE
 3. PRKJ
 4. HJSQ

Question ID : 26433057229
Option 1 ID : 264330223903
Option 2 ID : 264330223900
Option 3 ID : 264330223902
Option 4 ID : 264330223901
Status : Answered
Chosen Option : 3

Q.10 उस विकल्प का चयन करें, जो छठी संख्या से उसी प्रकार संबंधित है, जिस प्रकार पहली संख्या दूसरी संख्या से और तीसरी संख्या चौथी संख्या से संबंधित है।
124 : 4 :: 217 : 7 :: ? : 9

- Ans 1. 216
 2. 330
 3. 315
 4. 279

Question ID : 26433087206
Option 1 ID : 264330342463
Option 2 ID : 264330342462
Option 3 ID : 264330342464
Option 4 ID : 264330342461
Status : Answered
Chosen Option : 4

Q.11 उस विकल्प का चयन करें जो पांचवी संख्या से उसी प्रकार संबंधित है जैसे पहली संख्या दूसरी संख्या से और तीसरी संख्या चौथी संख्या से संबंधित है।
14 : 21 :: 12 : 18 :: 50 : ?

- Ans 1. 125
 2. 155
 3. 100
 4. 75

Question ID : 26433079108
Option 1 ID : 264330310438
Option 2 ID : 264330310439
Option 3 ID : 264330310437
Option 4 ID : 264330310436
Status : Answered
Chosen Option : 4

Q.12 शालिनी 5 km उत्तर की ओर झाड़करती है, फिर वह पूर्व की ओर मुड़ जाती है और 12 km झाड़व करती है। इसके बाद वह उत्तर की ओर मुड़ जाती है और 4 km झाड़व करती है। वह फिर से पूर्व की ओर मुड़ जाती है और 5 km झाड़करती है। शालिनी द्वारा तय की गई कुल दूरी कितनी है?

- Ans
- 1. 12 km
 - 2. 22 km
 - 3. 9 km
 - 4. 26 km

Question ID : 264330132104

Option 1 ID : 264330517511

Option 2 ID : 264330517514

Option 3 ID : 264330517512

Option 4 ID : 264330517513

Status : Answered

Chosen Option : 4

Q.13 सात दोस्तों के समूह में मायशा, मायरा, हीर, टिया, यश, सिया और आरव प्रत्येक की लंबाई भिन्न-भिन्न है। सिया अपने दोस्तों में तीसरी सबसे लंबी है। मायशा अपने दोस्तों में तीसरी सबसे छोटी है। आरव, यश और सिया से लंबा है। हीर और टिया, मायरा से छोटी हैं। आरव समूह में सबसे लंबा नहीं है। उनमें से कौन सबसे लंबा है?

- Ans
- 1. टिया
 - 2. हीर
 - 3. मायरा
 - 4. यश

Question ID : 264330122626

Option 1 ID : 264330480618

Option 2 ID : 264330480615

Option 3 ID : 264330480616

Option 4 ID : 264330480617

Status : Answered

Chosen Option : 3

Q.14 एक लड़के की ओर इशारा करते हुए मेघा ने कहा, "वह मेरे दादा/नाना की इकलौती संतान का इकलौता पुत्र है।" वह लड़का मेघा से किस प्रकार संबंधित है?

- Ans
- 1. चाचा
 - 2. भाई
 - 3. पुत्र
 - 4. नाती

Question ID : 264330130336

Option 1 ID : 264330510455

Option 2 ID : 264330510458

Option 3 ID : 264330510457

Option 4 ID : 264330510456

Status : Answered

Chosen Option : 2

Q.15 यदि A का अर्थ '+' है, B का अर्थ 'x' है, C का अर्थ '-' है और D का अर्थ '+' है, तो निम्नलिखित व्यंजक का मान क्या होगा?
60 D 4 B 330 A 3 C 100 = ?

- Ans 1. 400
 2. 408
 3. 404
 4. 402

Question ID : 264330139466

Option 1 ID : 264330546297

Option 2 ID : 264330546296

Option 3 ID : 264330546295

Option 4 ID : 264330546298

Status : Answered

Chosen Option : 1

Q.16 दर्पण को नीचे दर्शाए अनुसार MN पर रखे जाने पर दिए गए संयोजन की सही दर्पण छवि का चयन कीजिए।

h A 2 9 d q

M
|
N

- Ans 1. p b 9 7 A d
 2. b p e 5 A d
 3. p b e 5 A d
 4. p d e 5 A d

Question ID : 264330109214

Option 1 ID : 264330429135

Option 2 ID : 264330429133

Option 3 ID : 264330429134

Option 4 ID : 264330429136

Status : Answered

Chosen Option : 3

Q.17 दिए गए विकल्पों में से उस आकृति का चयन करें, जो निम्नलिखित श्रृंखला में प्रश्नचिह्न (?) को प्रतिस्थापित करेगी।

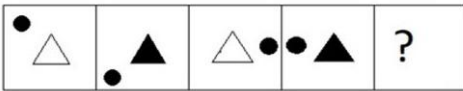

Ans

✓ 1.



✗ 2.



✗ 3.



✗ 4.



Question ID : 26433087165
Option 1 ID : 264330342297
Option 2 ID : 264330342300
Option 3 ID : 264330342298
Option 4 ID : 264330342299
Status : Answered
Chosen Option : 1

Prepare 50% Faster

Q.18 निम्नांकित श्रृंखला में पैटर्न को जारी रखने के लिए प्रश्नचिह्न (?) को किस आकृति द्वारा प्रतिस्थापित किया जाना चाहिए?

	2	▷	C	▷	
+ C ▷	A 2 C	2 + ▷	A C +		?
A	+	A	2		

Ans

✓ 1.

		+
C	2	▷
A		

✗ 2.

		+
2	▷	C
A		

✗ 3.

		2
+	A	C
▷		

✗ 4.

		+
2	A	▷
C		

Question ID : 264330129599

Option 1 ID : 264330507765

Option 2 ID : 264330507764

Option 3 ID : 264330507763

Option 4 ID : 264330507762

Status : Answered

Chosen Option : 1

Q.19 उस विकल्प का चयन करें जिसमें दी गई आकृति अंतर्निहित है (घुमाने की अनुमति नहीं है)।

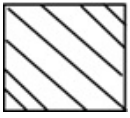

Ans

✗ 1.



✓ 2.

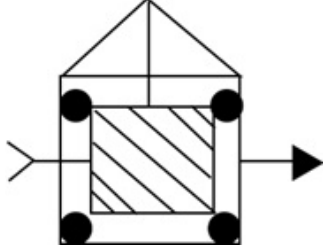

✗ 3.

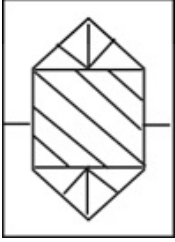

✗ 4.

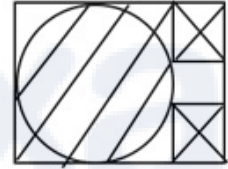

Question ID : 264330111653

Option 1 ID : 264330438697

Option 2 ID : 264330438700

Option 3 ID : 264330438698

Option 4 ID : 264330438699

Status : Answered

Chosen Option : 2

Q.20 उस विकल्प का चयन कीजिए जो पाँचवीं संख्या से उसी प्रकार संबंधित हो, जैसे दूसरी संख्या पहली संख्या से संबंधित है और चौथी संख्या तीसरी संख्या से संबंधित है।

9 : 84 :: 25 : 630 :: 16 : ?

Ans ✓ 1. 260

✗ 2. 625

✗ 3. 525

✗ 4. 290

Question ID : 26433089559

Option 1 ID : 264330351740

Option 2 ID : 264330351737

Option 3 ID : 264330351738

Option 4 ID : 264330351739

Status : Answered

Chosen Option : 1

Q.21 एक पासे के विभिन्न फलकों पर 1, 2, 3, 4, 5 और 6 लिखे गए हैं। उसी पासे की तीन अलग-अलग स्थितियाँ नीचे दर्शाई गई हैं। '2' दर्शाने वाले फलक के विपरीत फलक पर कौन-सी संख्या है?

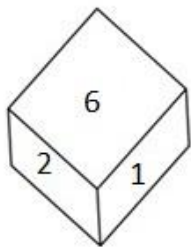

Figure 1

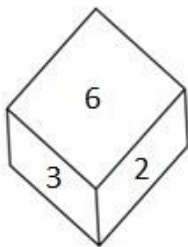

Figure 2

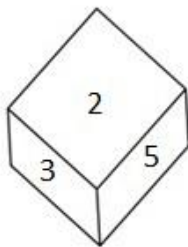

Figure 3

- Ans
- 1. 3
 - 2. 1
 - 3. 4
 - 4. 5

Question ID : 26433080730
 Option 1 ID : 264330316854
 Option 2 ID : 264330316853
 Option 3 ID : 264330316855
 Option 4 ID : 264330316856
 Status : Answered
 Chosen Option : 3

Q.22 तीन कथनों के बाद चार निष्कर्ष I, II, III और IV दिए गए हैं। कथनों को सत्य मानते हुए, भले ही वे सामान्य रूप से ज्ञात तथ्यों से भिन्न प्रतीत होते हों, निर्णय लीजिए कि कौन सा/से निष्कर्ष कथनों का तार्किक रूप से अनुसरण करता है/करते हैं।

कथन:

- कुछ कॉफी, तकिए हैं।
- कुछ तकिए, लैपटॉप हैं।
- कुछ लैपटॉप, पेन हैं।

निष्कर्ष:

- I. कुछ कॉफी, लैपटॉप हैं।
- II. कुछ तकिए, पेन हैं।
- III. कुछ पेन, लैपटॉप हैं।
- IV. कुछ पेन, तकिए हैं।

- Ans
- 1. केवल निष्कर्ष I अनुसरण करता है।
 - 2. केवल निष्कर्ष II अनुसरण करता है।
 - 3. केवल निष्कर्ष III अनुसरण करता है।
 - 4. केवल निष्कर्ष IV अनुसरण करता है।

Question ID : 26433093160
 Option 1 ID : 264330365893
 Option 2 ID : 264330365894
 Option 3 ID : 264330365895
 Option 4 ID : 264330365896
 Status : Answered
 Chosen Option : 3

Q.23 'E + F' का अर्थ है 'E, F का पिता है'
 'E - F' का अर्थ है 'E, F की बहन है'
 'E × F' का अर्थ है 'E, F का भाई है'
 'E ÷ F' का अर्थ है 'E, F का पुत्र है'
 यदि 'B - C + Z × G + Q है', तो C, Q से किस प्रकार संबंधित है?

- Ans 1. दादा
 2. पोता
 3. भाई
 4. पुत्र

Question ID : 264330102470
 Option 1 ID : 264330402311
 Option 2 ID : 264330402310
 Option 3 ID : 264330402312
 Option 4 ID : 264330402309
 Status : Answered
 Chosen Option : 1

Q.24 उस विकल्प का चयन करें जो उन अक्षरों का प्रतिनिधित्व करता है, जिन्हें नीचे दिए गए रिक्त स्थानों में क्रमिक रूप से बाएं से दाएं रखे जाने पर अक्षर श्रृंखला पूर्ण हो जाएगी।
 B _ _ CM _ NDC _ BN _ _ M _ _ DCM

- Ans 1. NDBMCDNB
 2. DNBMDCBN
 3. NDBMDCBN
 4. NDBMCDNB

Question ID : 26433089995
 Option 1 ID : 264330353459
 Option 2 ID : 264330353458
 Option 3 ID : 264330353457
 Option 4 ID : 264330353460
 Status : Answered
 Chosen Option : 3

Q.25 सोनू का जन्म 15 जून 1992 को हुआ था, उनका जन्म सप्ताह के किस दिन हुआ था?

- Ans 1. बुधवार
 2. रविवार
 3. सोमवार
 4. मंगलवार

Question ID : 264330144942
 Option 1 ID : 264330568026
 Option 2 ID : 264330568023
 Option 3 ID : 264330568024
 Option 4 ID : 264330568025
 Status : Answered
 Chosen Option : 3

Q.26 उस विकल्प का चयन करें जो पांचवीं संख्या से उसी प्रकार संबंधित है जैसे पहली संख्या दूसरी संख्या से और तीसरी संख्या चौथी संख्या से संबंधित है।
35 : 1225 :: 55 : 3025 :: 75 : ?

- Ans 1. 5525
 2. 8725
 3. 5625
 4. 6656

Question ID : 26433079107
Option 1 ID : 264330310435
Option 2 ID : 264330310432
Option 3 ID : 264330310434
Option 4 ID : 264330310433
Status : Answered
Chosen Option : 3

Q.27 उस विकल्प का चयन कीजिए जो दिए गए शब्दों को उस सही क्रम में दर्शाता है जिस क्रम में वे अंग्रेजी शब्दकोश में आएंगे।

1. Languish
2. Larder
3. Lantern
4. Languid
5. Lapse

- Ans 1. 14523
 2. 34521
 3. 15432
 4. 41352

Question ID : 264330137317
Option 1 ID : 264330537896
Option 2 ID : 264330537897
Option 3 ID : 264330537898
Option 4 ID : 264330537895
Status : Answered
Chosen Option : 4

Q.28 उस विकल्प का चयन करें जो तीसरे शब्द से उसी प्रकार संबंधित है जिस प्रकार दूसरा शब्द पहले शब्द से संबंधित है। (शब्दों को अर्थपूर्ण अंग्रेजी/हिन्दी शब्दों के रूप में माना जाना चाहिए और इन्हें शब्द में अक्षरों की संख्या/व्यंजनों की संख्या/स्वरों की संख्या के आधार पर एक-दूसरे से संबद्ध नहीं किया जाना चाहिए।)

ताजमहल : भारत :: स्टैच्यू ऑफ लिबर्टी : ?

- Ans 1. अफ्रीका
 2. संयुक्त राज्य अमेरिका
 3. ऑस्ट्रेलिया
 4. इंग्लैंड

Question ID : 26433087287
Option 1 ID : 264330342788
Option 2 ID : 264330342787
Option 3 ID : 264330342786
Option 4 ID : 264330342785
Status : Answered
Chosen Option : 2

Q.29 बिंदु A, बिंदु B से 35 m उत्तर में है। बिंदु C, बिंदु B से 28 m पश्चिम में है। बिंदु D, बिंदु C से 25 m दक्षिण में है। बिंदु E, बिंदु D से 14 m पश्चिम में है। बिंदु F, बिंदु E से 40 m उत्तर में है। बिंदु F के सापेक्ष बिंदु B किस दिशा में है?

- Ans
- 1. उत्तर
 - 2. पश्चिम
 - 3. उत्तर-पूर्व
 - 4. दक्षिण-पूर्व

Question ID : 264330131629

Option 1 ID : 264330515618

Option 2 ID : 264330515616

Option 3 ID : 264330515615

Option 4 ID : 264330515617

Status : Answered

Chosen Option : 4

Q.30 उस समुच्चय का चयन कीजिए, जिसमें संख्याएँ उसी तरह से संबंधित हैं, जिस प्रकार दिए गए समुच्चय की संख्याएँ आपस में संबंधित हैं। (नोट: संख्याओं को उसके घटक अंकों में विभाजित किए बिना, पूर्ण संख्याओं पर ही गणितीय संक्रियाएँ की जानी चाहिए। जैसे 13 - मान लीजिए 13 पर गणितीय संक्रियाएँ जैसे कि 13 में जोड़ना/घटाना/गुणा करना आदि किया जा सकता है। 13 को 1 और 3 में तोड़कर और फिर 1 और 3 पर गणितीय संक्रियाएँ करने की अनुमति नहीं है।)

(4, 8, 35)

(3, 5, 23)

- Ans
- 1. (5, 11, 46)
 - 2. (10, 34, 139)
 - 3. (6, 14, 59)
 - 4. (7, 17, 75)

Question ID : 26433078966

Option 1 ID : 264330309876

Option 2 ID : 264330309879

Option 3 ID : 264330309877

Option 4 ID : 264330309878

Status : Not Answered

Chosen Option : --

Q.31 दिए गए कथनों और निष्कर्षों को ध्यानपूर्वक पढ़ें। यह मानते हुए कि कथनों में दी गई जानकारी सत्य है, भले ही वह सामान्य रूप से ज्ञात तथ्यों से भिन्न प्रतीत होती हो, और तय करें कि दिए गए निष्कर्षों में से कौन-सा/से निष्कर्ष कथनों का तार्किक रूप से अनुसरण करता है/करते हैं।

कथन:

1) कुछ ट्रा उज्ज्वल हैं।

2) सभी पैट जींस हैं।

3) सभी जींस कोट हैं।

निष्कर्ष:

I. सभी पैट कोट हैं।

II. कम से कम कुछ ट्रा उज्ज्वल हैं।

- Ans
- 1. केवल निष्कर्ष I अनुसरण करता है।
 - 2. निष्कर्ष I और II दोनों अनुसरण करते हैं।
 - 3. न तो निष्कर्ष I अनुसरण करता और न ही II अनुसरण करता है।
 - 4. केवल निष्कर्ष II अनुसरण करता है।

Question ID : 26433092432

Option 1 ID : 264330363017

Option 2 ID : 264330363020

Option 3 ID : 264330363019

Option 4 ID : 264330363018

Status : Answered

Chosen Option : 2

Q.32 "A" को प्रतिस्थापित करने के लिए गणितीय चिह्नों के उस सही संयोजन का चयन कीजिए, जो निम्नलिखित समीकरण को संतुलित करता है।
48 A 12 A 24 A 3 A 8 A 5 A 4

- Ans 1. -, +, x, =, +, +
 2. -, +, +, x, =, +
 3. -, +, +, =, x, +
 4. +, -, +, x, =, +

Question ID : 264330129639
Option 1 ID : 264330507922
Option 2 ID : 264330507923
Option 3 ID : 264330507925
Option 4 ID : 264330507924
Status : Answered
Chosen Option : 3

Q.33 यदि '+' का अर्थ '-' है, '-' का अर्थ 'x' है, 'x' का अर्थ '+' है और '-' का अर्थ '+' है, तो निम्नलिखित समीकरण में '?' के स्थान पर क्या आएगा?
 $62 \div 12 \times 3 - 8 + 5 = ?$

- Ans 1. 94
 2. 87
 3. 99
 4. 89

Question ID : 264330101135
Option 1 ID : 264330397088
Option 2 ID : 264330397087
Option 3 ID : 264330397085
Option 4 ID : 264330397086
Status : Answered
Chosen Option : 4

Q.34 दिए गए विकल्पों में से उस संख्या का चयन करें जो निम्नलिखित श्रृंखला में प्रश्नवाचक चिह्न (?) को प्रतिस्थापित कर सकती है।
28, 39, 61, 94, 138, ?

- Ans 1. 182
 2. 204
 3. 193
 4. 195

Question ID : 264330110766
Option 1 ID : 264330435341
Option 2 ID : 264330435344
Option 3 ID : 264330435343
Option 4 ID : 264330435342
Status : Answered
Chosen Option : 3

Q.35 उस विकल्प का चयन करें, जिसके अक्षरों को नीचे दिए गए रिक्त स्थान में क्रमिक रूप से बाएँ से दाएँ रखे जाने पर अक्षर श्रृंखला पूरी हो जाएगी।
B _ V _ _ T _ G B T _ G _ _ V G

- Ans 1. TGBVVB T
 2. TGBVGV B
 3. GTBVVB G
 4. TGGBVB G

Question ID : 26433081683
 Option 1 ID : 264330320565
 Option 2 ID : 264330320568
 Option 3 ID : 264330320566
 Option 4 ID : 264330320567
 Status : Answered
 Chosen Option : 1

Q.36 एक निश्चित कूट भाषा में, 'STORM' को '12694' के रूप में लिखा जाता है और 'TREND' को '29554' के रूप में लिखा जाता है। उसी भाषा में 'WATER' को कैसे लिखा जाएगा?

- Ans 1. 43216
 2. 23564
 3. 23968
 4. 51259

Question ID : 26433082567
 Option 1 ID : 264330324104
 Option 2 ID : 264330324102
 Option 3 ID : 264330324101
 Option 4 ID : 264330324103
 Status : Answered
 Chosen Option : 4

Prepare 50% Faster

Q.37 कागज के एक टुकड़े को मोड़ने का क्रम और मोड़े गए कागज को काटने का ढंग नीचे दर्शाया गया है। उस आकृति का चयन करें, जो कागज के खुले हुए रूप से सबसे अधिक मिलती-जुलती हो।

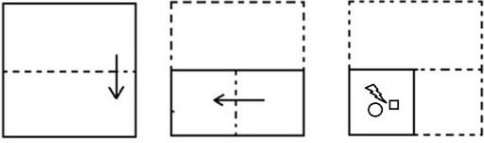

Ans

✗ 1.

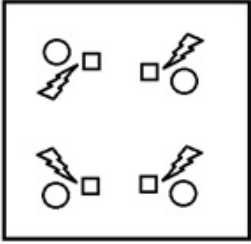

✗ 2.

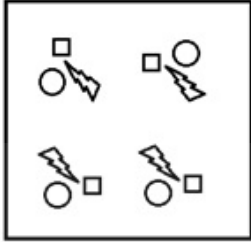

✓ 3.

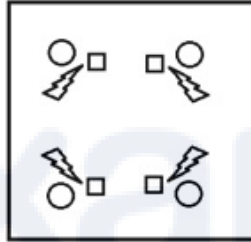

✗ 4.

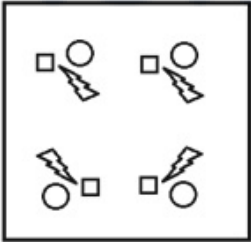

Question ID : 264330103217

Option 1 ID : 264330405174

Option 2 ID : 264330405176

Option 3 ID : 264330405173

Option 4 ID : 264330405175

Status : Answered

Chosen Option : 3

Q.38 उस विकल्प का चयन कीजिए जो नीचे दिए गए शब्दों के उस सही क्रम को दर्शाता है, जिस क्रम में वे अंग्रेजी शब्दकोश में आएंगे।

1. Logwood
2. Logarithm
3. Logically
4. Logophile
5. Logistic
6. Logotype

- Ans
- 1. 2, 5, 3, 4, 6, 1
 - 2. 2, 3, 5, 1, 4, 6
 - 3. 2, 3, 5, 4, 6, 1
 - 4. 2, 5, 3, 6, 1, 4

Question ID : 264330144930

Option 1 ID : 264330567976

Option 2 ID : 264330567977

Option 3 ID : 264330567978

Option 4 ID : 264330567975

Status : Answered

Chosen Option : 3

Q.39 निम्नलिखित में से कौन-सी संख्या दी गई श्रृंखला में प्रश्न चिह्न (?) को प्रतिस्थापित करेगी?
131, 133, 181, ?, 239

- Ans
- 1. 193
 - 2. 183
 - 3. 229
 - 4. 185

Question ID : 26433082429

Option 1 ID : 264330323549

Option 2 ID : 264330323551

Option 3 ID : 264330323552

Option 4 ID : 264330323550

Status : Answered

Chosen Option : 2

Q.40 8 मित्र - जेक, केन, लिली, देव, मिनी, नैन्सी, ओम और पोली एक वर्गाकार मेज के चारों ओर इस प्रकार बैठे हैं कि उनमें से चार मेज के कोनों पर बैठे हैं और अन्य चार मेज की चारों भुजाओं में से प्रत्येक के मध्य में बैठे हैं। सभी मेज के केंद्र की ओर मुख करके बैठे हैं। न तो जेक और न ही ओम, मिनी का निकटतम पड़ोसी है। लिली, ओम के बाएं चौथे स्थान पर बैठी है। नैन्सी किसी भी भुजा के मध्य में नहीं बैठी है। ओम, जेक के दाएं दूसरे स्थान पर बैठा है। जेक किसी भी भुजा के मध्य में नहीं बैठा है। मिनी किसी एक भुजा के मध्य में बैठी है। केन और मिनी के मध्य में केवल एक व्यक्ति बैठा है। पोली, ओम का निकटतम पड़ोसी नहीं है।
जेक के दाएं चौथे स्थान पर कौन बैठा/बैठी है?

- Ans
- 1. लिली
 - 2. मिनी
 - 3. नैन्सी
 - 4. ओम

Question ID : 26433085632

Option 1 ID : 264330336229

Option 2 ID : 264330336230

Option 3 ID : 264330336232

Option 4 ID : 264330336231

Status : Answered

Chosen Option : 3

Q.41 छह सहकर्मी - J, K, L, M, N और O - दो पंक्तियों में बैठे हैं, प्रत्येक पंक्ति में 3 लोग हैं, जो एक दूसरे के सामने हैं। आसन्न व्यक्तियों के बीच समान दूरी है। एक पंक्ति में प्रत्येक व्यक्ति, दूसरी पंक्ति के किसी अन्य व्यक्ति की ओर अभिमुख है। M, L का निकटतम पड़ोसी है। J, L के बाएं दूसरे स्थान पर बैठा है। N, पंक्ति के किसी भी छोर पर नहीं बैठा है। O, जो N का निकटतम पड़ोसी है, J के तिर्यक रूप से सामने बैठा है।

M के सामने निम्नलिखित में से कौन बैठा है?

Ans 1. J

2. N

3. L

4. O

Question ID : 26433091576

Option 1 ID : 264330359672

Option 2 ID : 264330359669

Option 3 ID : 264330359671

Option 4 ID : 264330359670

Status : Answered

Chosen Option : 2

Q.42 दिए गए विकल्पों में से उस संख्या का चयन कीजिए जो निम्नलिखित श्रृंखला में प्रश्न चिह्न (?) के स्थान पर आ सकती है।

39, 51, 75, 111, ?

Ans 1. 163

2. 159

3. 145

4. 153

Question ID : 264330112664

Option 1 ID : 264330442744

Option 2 ID : 264330442743

Option 3 ID : 264330442741

Option 4 ID : 264330442742

Status : Answered

Chosen Option : 2

Q.43 विकल्पों में दिया गया कौन सा अक्षर-समूह नीचे दी गई श्रृंखला में प्रश्न चिह्न (?) के स्थान पर आकर उसे पूर्ण करेगा?

SWBM, OSXI, ?, GKPA, CGLW

Ans 1. KOTE

2. KOTD

3. KOUE

4. KOTF

Question ID : 26433067957

Option 1 ID : 264330266343

Option 2 ID : 264330266341

Option 3 ID : 264330266342

Option 4 ID : 264330266340

Status : Answered

Chosen Option : 1

Q.44 दो कथनों के बाद दो निष्कर्ष I और II दिए गए हैं। कथनों को सत्य मानते हुए, भले ही वे सामान्य रूप से ज्ञात तथ्यों से भिन्न प्रतीत होते हों, निर्णय लीजिए कि कौन सा/से निष्कर्ष कथनों का तार्किक रूप से अनुसरण करता/करते है/हैं।

कथन:

सभी चाबियाँ, ताले हैं।

सभी ताले, हैंडल हैं।

निष्कर्ष:

I. सभी ताले, चाबियाँ हैं।

II. सभी हैंडल, चाबियाँ हैं।

Ans ✓ 1. न तो निष्कर्ष I अनुसरण करता है और न ही II अनुसरण करता है

✗ 2. केवल निष्कर्ष II अनुसरण करता है

✗ 3. केवल निष्कर्ष I अनुसरण करता है

✗ 4. निष्कर्ष I और II दोनों अनुसरण करते हैं

Question ID : 264330144957

Option 1 ID : 264330568086

Option 2 ID : 264330568084

Option 3 ID : 264330568083

Option 4 ID : 264330568085

Status : Answered

Chosen Option : 1



Prepare 50% Faster

Q.45 निम्नांकित श्रृंखला में पैटर्न को जारी रखने के लिए प्रश्नचिह्न (?) को किस आकृति द्वारा प्रतिस्थापित किया जाना चाहिए?

B		X		N		=				
	△	X		B	△		X	=	N	X
	N	=		=	N		△	B	B	△
										?

Ans

✗ 1.

B		
	=	△
	N	X

✗ 2.

=		
	B	N
	△	X

✗ 3.

N		
	△	B
	X	=

✓ 4.

△		
	=	B
	X	N

Question ID : 264330129595

Option 1 ID : 264330507749

Option 2 ID : 264330507746

Option 3 ID : 264330507748

Option 4 ID : 264330507747

Status : Answered

Chosen Option : 4

Q.46 उस विकल्प का चयन करें जिसमें दी गई आकृति अंतर्निहित है (घुमाने की अनुमति नहीं है)।



Ans

✗ 1.

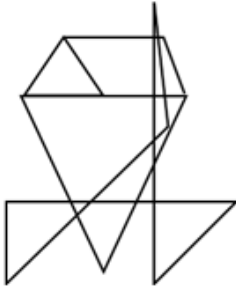

✗ 2.

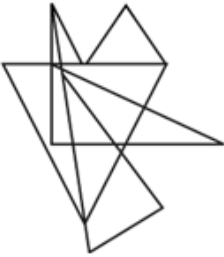

✓ 3.



✗ 4.

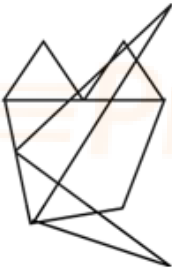

Question ID : 264330132507

Option 1 ID : 264330519125

Option 2 ID : 264330519123

Option 3 ID : 264330519126

Option 4 ID : 264330519124

Status : Answered

Chosen Option : 3

Q.47 उस शब्द-युग्म का चयन कीजिए, जो ठीक उसी संबंध का सर्वोत्तम निरूपण करता है, जो संबंध इस दिए गए शब्द-युग्म में है। (शब्दों को अंग्रेजी के अर्थपूर्ण शब्दों के रूप में समझा जाना चाहिए और इनका अक्षरों की संख्या/व्यंजनों की संख्या/स्वरों की संख्या के आधार पर एक दूसरे से संबंध नहीं होना चाहिए।)

सीडी : कंप्यूटर

- Ans 1. इंजन : स्कूटर
 2. पेन : पेपर
 3. पिन : सेफ्टी
 4. कार्ड : ग्रीटिंग

Question ID : 264330144922
 Option 1 ID : 264330567943
 Option 2 ID : 264330567944
 Option 3 ID : 264330567945
 Option 4 ID : 264330567946
 Status : Answered
 Chosen Option : 1

Q.48 निम्नलिखित चार अक्षर-समूहों में से तीन किसी निश्चित तरीके से आपस में संगत हैं जबकि कोई एक उनसे असंगत है। असंगत अक्षर-समूह का चयन कीजिए।

- Ans 1. JPKM
 2. KPLN
 3. DWEG
 4. FUGI

Question ID : 26433068788
 Option 1 ID : 264330269666
 Option 2 ID : 264330269664
 Option 3 ID : 264330269667
 Option 4 ID : 264330269665
 Status : Answered
 Chosen Option : 1

Q.49 दिए गए विकल्पों में से उस संख्या का चयन कीजिए जो निम्नलिखित श्रृंखला में प्रश्न चिह्न (?) के स्थान पर आ सकती है।
 18, 21, 27, 36, ?

- Ans 1. 51
 2. 48
 3. 45
 4. 54

Question ID : 264330112663
 Option 1 ID : 264330442739
 Option 2 ID : 264330442738
 Option 3 ID : 264330442737
 Option 4 ID : 264330442740
 Status : Answered
 Chosen Option : 2

Q.50 यदि 'A' का अर्थ '+' है, 'B' का अर्थ '×' है, 'C' का अर्थ '-' है और 'D' का अर्थ '-' है, तो निम्नलिखित समीकरण में प्रश्न चिह्न (?) के स्थान पर क्या आएगा?
34 B 4 D 16 C 30 A 2 = ?

- Ans
- 1. 138
 - 2. 137
 - 3. 136
 - 4. 135

Question ID : 264330141907
Option 1 ID : 264330555950
Option 2 ID : 264330555949
Option 3 ID : 264330555948
Option 4 ID : 264330555947
Status : Answered
Chosen Option : 4

Section : General Awareness

Q.1 प्रथम दक्षिण एशियाई संघ खेल का आयोजन कब और कहाँ हुआ था?

- Ans
- 1. 1983 में, ढाका
 - 2. 1951 में, नई दिल्ली
 - 3. 1984 में, काठमांडू
 - 4. 1981 में, नई दिल्ली

Question ID : 264330110364
Option 1 ID : 264330433736
Option 2 ID : 264330433733
Option 3 ID : 264330433734
Option 4 ID : 264330433735
Status : Answered
Chosen Option : 4

Q.2 भारत का सबसे प्राचीन किला निम्नलिखित में से कौन-सा है?

- Ans
- 1. कांगड़ा किला
 - 2. मेहरानगढ़ किला
 - 3. श्रीरंगपट्टण किला
 - 4. गोलकोंडा किला

Question ID : 26433071462
Option 1 ID : 264330280273
Option 2 ID : 264330280272
Option 3 ID : 264330280275
Option 4 ID : 264330280274
Status : Answered
Chosen Option : 4

Q.3 निम्नलिखित में से कौन-सा अनुच्छेद किसी व्यक्ति को समान अपराध के लिए एक से अधिक बार दंडित होने से बचाता है?

- Ans
- 1. अनुच्छेद 21
 - 2. अनुच्छेद 23
 - 3. अनुच्छेद 22
 - 4. अनुच्छेद 20

Question ID : 264330112774
Option 1 ID : 264330443182
Option 2 ID : 264330443184
Option 3 ID : 264330443183
Option 4 ID : 264330443181
Status : Answered
Chosen Option : 4

Q.4 काठियावाड़ का जूनागढ़ शिलालेख निम्नलिखित में से किस राजा से संबंधित है?

- Ans
- 1. कनिष्क
 - 2. रुद्रदामन प्रथम
 - 3. नरसिंहवर्मन
 - 4. गौतमीपुत्र सातकर्ण

Question ID : 264330165283
Option 1 ID : 264330648219
Option 2 ID : 264330648222
Option 3 ID : 264330648221
Option 4 ID : 264330648220
Status : Answered
Chosen Option : 1

Q.5 फुटबॉल विश्व कप का प्रारंभ किस वर्ष में हुआ था?

- Ans
- 1. 1928 में
 - 2. 1930 में
 - 3. 1932 में
 - 4. 1934 में

Question ID : 264330110358
Option 1 ID : 264330433709
Option 2 ID : 264330433710
Option 3 ID : 264330433711
Option 4 ID : 264330433712
Status : Answered
Chosen Option : 3

Q.6 भारत में सीमेंट उद्योग को पूर्णतः विनियंत्रित कब किया गया था?

- Ans
- 1. 1991 में
 - 2. 1989 में
 - 3. 1982 में
 - 4. 1980 में

Question ID : 26433064531
Option 1 ID : 264330252719
Option 2 ID : 264330252718
Option 3 ID : 264330252717
Option 4 ID : 264330252716
Status : Not Answered
Chosen Option : --

Q.7 आलू चिप्स के निर्माता आमतौर पर _____ चिप्स की थैलियों को मुख्य रूप से नाइट्रो जर्बैसी गैस से भर देते हैं।

- Ans
- ✓ 1. चिप्स को ऑक्सीकृत होने से बचाने के लिए
 - ✗ 2. परिवहन के दौरान चिप्स को टूटने से बचाने के लिए
 - ✗ 3. जीवाणु संबंधी क्रिया से चिप्स के अपघटन को रोकने के लिए
 - ✗ 4. व्यावसायिक लाभ के लिए पैकेटों को बड़ा दिखाने के लिए

Question ID : 264330169293

Option 1 ID : 264330663954

Option 2 ID : 264330663951

Option 3 ID : 264330663952

Option 4 ID : 264330663953

Status : Answered

Chosen Option : 1

Q.8 इनमें से किसने 'कितने पाकिस्तान' नामक उपन्यास की रचना की थी, जिस पर उन्हें साहित्य अकादमी पुरस्कार प्राप्त हुआ था?

- Ans
- ✗ 1. अमृता प्रीतम
 - ✗ 2. राजेश्वर सिंह
 - ✓ 3. कमलेश्वर
 - ✗ 4. श्रीलाल शुक्ल

Question ID : 264330144837

Option 1 ID : 264330567604

Option 2 ID : 264330567605

Option 3 ID : 264330567603

Option 4 ID : 264330567606

Status : Not Answered

Chosen Option : --

Q.9 बहुआयामी गरीबी सूचकांक प्रगति रिपोर्ट 2023 के अनुसार निम्नलिखित में से किस राज्य में एमपीआई (MPI) गरीबों की संख्या में सबसे अधिक गिरावट दर्ज की गई?

- Ans
- ✗ 1. हिमाचल प्रदेश
 - ✗ 2. उत्तराखंड
 - ✓ 3. उत्तर प्रदेश
 - ✗ 4. असम

Question ID : 264330166816

Option 1 ID : 264330654302

Option 2 ID : 264330654301

Option 3 ID : 264330654300

Option 4 ID : 264330654299

Status : Answered

Chosen Option : 4

Q.10 क्षारीय मृदा धातुओं के परमाणु क्रमांक के अनुसार निम्नलिखित में से कौन-सा सही क्रम है?

- Ans 1. Ba < Mg < Ca < Sr < Be
 2. Be < Mg < Ca < Sr < Ba
 3. Be < Mg < Sr < Ca < Ba
 4. Mg < Be < Ca < Sr < Ba

Question ID : 264330131779

Option 1 ID : 264330516216

Option 2 ID : 264330516215

Option 3 ID : 264330516218

Option 4 ID : 264330516217

Status : Not Answered

Chosen Option : --

Q.11 देव समाज का मुख्यालय कहाँ स्थित था?

- Ans 1. बॉम्बे
 2. पूना
 3. कलकत्ता
 4. लाहौर

Question ID : 264330112196

Option 1 ID : 264330440870

Option 2 ID : 264330440872

Option 3 ID : 264330440871

Option 4 ID : 264330440869

Status : Not Answered

Chosen Option : --

Q.12 भारत की 2011 की जनगणना के अनुसार, भारत के केंद्र शासित प्रदेशों के किस समूह की साक्षरता दर सर्वाधिक है?

- Ans 1. लक्षद्वीप, दमन एवं दीव
 2. चंडीगढ़, दमन एवं दीव
 3. दमन एवं दीव और दिल्ली
 4. अंडमान एवं निकोबार द्वीप समूह और पुदुचेरी

Question ID : 264330119914

Option 1 ID : 264330469933

Option 2 ID : 264330469931

Option 3 ID : 264330469932

Option 4 ID : 264330469934

Status : Answered

Chosen Option : 3

Q.13 जनवरी 2023 तक प्राप्त जानकारी के अनुसार, केंद्रीय विद्युत मंत्री कौन हैं?

- Ans 1. गजेन्द्र सिंह शेखावत
 2. स्मृति ईरानी
 3. पीयूष गोयल
 4. राज कुमार सिंह

Question ID : 264330165222

Option 1 ID : 264330647988

Option 2 ID : 264330647987

Option 3 ID : 264330647990

Option 4 ID : 264330647989

Status : Answered

Chosen Option : 4

Q.14 निम्नलिखित में से कौन-सा खाद्य सुरक्षा प्रबंधन प्रणाली से संबंधित नहीं है?

- Ans
- 1. जोखिम विश्लेषण महत्वपूर्ण नियंत्रण बिंदु (HACCP)
 - 2. अच्छी विनिर्माण पद्धतियां (GMP)
 - 3. अच्छी संचालन पद्धतियां (GHP)
 - 4. चोट का खतरा

Question ID : 264330131708
Option 1 ID : 264330515933
Option 2 ID : 264330515931
Option 3 ID : 264330515932
Option 4 ID : 264330515934
Status : Not Answered
Chosen Option : --

Q.15 NBFC-MFI के अलावा NBFC के लिए सूक्ष्मवित्त ऋण की अधिकतम सीमा _____ होती है।

- Ans
- 1. कुल आस्तियों की 25%
 - 2. कुल ऋणों की 85%
 - 3. कुल आस्तियों की 75%
 - 4. कुल इक्विटी की 25%

Question ID : 264330109084
Option 1 ID : 264330428614
Option 2 ID : 264330428616
Option 3 ID : 264330428613
Option 4 ID : 264330428615
Status : Not Answered
Chosen Option : --

Q.16 क्रिकेट विश्व कप की शुरुआत किस वर्ष में हुई थी?

- Ans
- 1. 1985 में
 - 2. 1980 में
 - 3. 1975 में
 - 4. 1970 में

Question ID : 264330110355
Option 1 ID : 264330433699
Option 2 ID : 264330433697
Option 3 ID : 264330433700
Option 4 ID : 264330433698
Status : Not Answered
Chosen Option : --

Q.17 निम्नलिखित में से किसे भारतीय नृत्य में उनके योगदान के लिए कला के क्षेत्र में पद्म श्री 2021 से सम्मानित किया गया?

- Ans
- 1. वाणी जयराम
 - 2. राधे श्याम बारले
 - 3. हेमंत चौहान
 - 4. प्रेमजीत बारिया

Question ID : 264330130531
Option 1 ID : 264330511235
Option 2 ID : 264330511236
Option 3 ID : 264330511238
Option 4 ID : 264330511237
Status : Not Answered
Chosen Option : --

Q.18 बहमनी साम्राज्य के विघटन के बाद कितने स्वतंत्र राज्यों का उदय हुआ?

- Ans 1. 4
 2. 3
 3. 6
 4. 5

Question ID : 264330109017

Option 1 ID : 264330428346

Option 2 ID : 264330428345

Option 3 ID : 264330428348

Option 4 ID : 264330428347

Status : Not Answered

Chosen Option : --

Q.19 निम्नलिखित में से किस कंपनी ने लंबी दूरी तक तरल पदार्थ और गैसों के परिवहन के साधन के रूप में एशिया की पहली क्रॉस-कंट्री पाइपलाइन का निर्माण किया था?

- Ans 1. इंडियन ऑयल कॉरपोरेशन
 2. भारत पेट्रो स्मि
 3. ऑयल एण्ड नेचुरल गैस कॉरपोरेशन
 4. ऑयल इंडिया लिमिटेड

Question ID : 264330163205

Option 1 ID : 264330640133

Option 2 ID : 264330640134

Option 3 ID : 264330640131

Option 4 ID : 264330640132

Status : Not Answered

Chosen Option : --

Q.20 निम्नलिखित में से कौन शास्त्रीय कर्नाटक संगीत के एक प्रतिपादक थे?

- Ans 1. उस्ताद बड़े गुलाम अली
 2. पंडित भीमसेन जोशी
 3. डॉ. बालमुरलीकृष्ण
 4. अब्दुल करीम खान

Question ID : 26433064246

Option 1 ID : 264330251576

Option 2 ID : 264330251577

Option 3 ID : 264330251578

Option 4 ID : 264330251579

Status : Not Answered

Chosen Option : --

Q.21 हिंदू पंचांग के अनुसार भगवान महावीर स्वामी की जयंती किस महीने में मनाई जाती है?

- Ans 1. कार्तिक
 2. वैशाख
 3. माघ
 4. चैत्र

Question ID : 26433074090

Option 1 ID : 264330290481

Option 2 ID : 264330290480

Option 3 ID : 264330290483

Option 4 ID : 264330290482

Status : Not Answered

Chosen Option : --

Q.22 भागीरथी और अलकनंदा नदियां मिलकर किस नदी का निर्माण करती हैं?

- Ans 1. गंगा
 2. झेलम
 3. यमुना
 4. रावी

Question ID : 264330169997
Option 1 ID : 264330666664
Option 2 ID : 264330666665
Option 3 ID : 264330666663
Option 4 ID : 264330666666
Status : Answered
Chosen Option : 3

Q.23 निम्नलिखित में से किस स्पर्धा को प्रायः घोड़े की पीठ पर जिमनास्टिक्स और नृत्य करने रूप में वर्णित किया जाता है?

- Ans 1. घुड़सवार भाला-युद्ध (Jousting)
 2. लंबी बाधा दौड़ (Steeplechase)
 3. अश्वारोही कुदान (equestrian vaulting)
 4. बैरल दौड़ (Barrel racing)

Question ID : 264330119289
Option 1 ID : 264330467443
Option 2 ID : 264330467444
Option 3 ID : 264330467446
Option 4 ID : 264330467445
Status : Not Answered
Chosen Option : --

Q.24 1850 में, कश्मीर को निम्नलिखित में से किस संधि के तहत जम्मू के डोगरा वंश को बेच दिया गया था?

- Ans 1. पुरंदर की संधि
 2. इलाहाबाद की संधि
 3. अमृतसर की संधि
 4. सुगौली की संधि

Question ID : 264330165391
Option 1 ID : 264330648646
Option 2 ID : 264330648643
Option 3 ID : 264330648644
Option 4 ID : 264330648645
Status : Not Answered
Chosen Option : --

Q.25 पारिस्थितिकी के किस उपखंड को कभी-कभी 'प्रजाति पारिस्थितिकी' के रूप में परिभाषित किया जाता है और यह शरीरक्रियात्मक पारिस्थितिकी से भी जुड़ा हुआ है?

- Ans 1. जीवाश्मिकी (Palaeontology)
 2. स्वपारिस्थितिकी (Autecology)
 3. संपारिस्थितिकी (Synecology)
 4. पक्षीविज्ञान (Ornithology)

Question ID : 264330113475
Option 1 ID : 264330445987
Option 2 ID : 264330445986
Option 3 ID : 264330445985
Option 4 ID : 264330445988
Status : Not Answered
Chosen Option : --

Q.26 निम्नलिखित में से कौन-सा स्थान एक अर्धगोलाकार गुंबद-संरचित स्मारक (स्तूप) के लिए प्रसिद्ध है?

- Ans 1. जशपुर
 2. सांची
 3. कोल्हापुर
 4. रांची

Question ID : 264330141802
Option 1 ID : 264330555530
Option 2 ID : 264330555528
Option 3 ID : 264330555529
Option 4 ID : 264330555527
Status : Answered
Chosen Option : 2

Q.27 गारो, खासी और जयंतिया पहाड़ियाँ निम्न में से किसके उपखंड हैं?

- Ans 1. असम घाटी
 2. मेघालय के पठार
 3. बराक बेसिन
 4. सूरमा बेसिन

Question ID : 264330166799
Option 1 ID : 264330654231
Option 2 ID : 264330654233
Option 3 ID : 264330654232
Option 4 ID : 264330654234
Status : Answered
Chosen Option : 1

Q.28 एक अवतल गोलाकार दर्पण की वक्रता त्रिज्या 30 cm है। एक वस्तु को मुख्य अक्ष पर दर्पण के सामने ध्रुव से 15 cm की दूरी पर रखा गया था। निर्मित छवि की क्रमशः स्थिति, आकार और प्रकृति के लिए सही विकल्प का चयन कीजिए।

- Ans 1. फोकस पर, अत्यधिक छोटे बिंदु-आकारीय, वास्तविक और उलटी
 2. अनंत पर, अत्यधिक विवर्धित, वास्तविक और उलटी
 3. फोकस और केंद्र के बीच में, छोटी, वास्तविक और उलटी
 4. दर्पण के पीछे, विवर्धित, आभासी और सीधी

Question ID : 264330169282
Option 1 ID : 264330663910
Option 2 ID : 264330663909
Option 3 ID : 264330663908
Option 4 ID : 264330663907
Status : Not Answered
Chosen Option : --

Q.29 कौन-सी कोशिकीय संरचना अंतरावस्था पर कोशिका की गतिशीलता, आसंजन और ध्रुवता को नियंत्रित करती है, और समसूत्रण के दौरान स्पिंडल ध्रुवों के संगठन की सुविधा प्रदान करती है?

- Ans
- ✓ 1. सेंट्रो सो(Centrosomes)
 - ✗ 2. ग्लाइऑक्सीसोम (Glyoxysomes)
 - ✗ 3. लाइसोसोम (Lysosomes)
 - ✗ 4. पेरोक्सीसोम (Peroxisomes)

Question ID : 264330113473
Option 1 ID : 264330445977
Option 2 ID : 264330445980
Option 3 ID : 264330445978
Option 4 ID : 264330445979
Status : Not Answered
Chosen Option : --

Q.30 एथलेटिक्स फेडरेशन ऑफ इंडिया का गठन किस वर्ष में हुआ था?

- Ans
- ✗ 1. 1948 में
 - ✓ 2. 1946 में
 - ✗ 3. 1936 में
 - ✗ 4. 1950 में

Question ID : 264330110356
Option 1 ID : 264330433703
Option 2 ID : 264330433702
Option 3 ID : 264330433701
Option 4 ID : 264330433704
Status : Not Answered
Chosen Option : --

Q.31 तीसरी पंचवर्षीय योजना के लक्ष्यों की प्राप्ति में असफलता का कारण निम्नलिखित में से किसे नहीं माना जाता है?

- Ans
- ✗ 1. भारत पाक युद्ध
 - ✗ 2. चीन का आक्रमण
 - ✗ 3. भयंकर अकाल
 - ✓ 4. सरकार बदलना

Question ID : 264330111733
Option 1 ID : 264330439020
Option 2 ID : 264330439018
Option 3 ID : 264330439017
Option 4 ID : 264330439019
Status : Not Answered
Chosen Option : --

Q.32 मार्च 2023 में, डॉ. मनसुख मंडाविया और श्री अश्विनी वैष्णव ने निम्नलिखित में से किस स्थान पर जन औषधि ट्रेन को हरी झंडी दिखाई?

- Ans
- 1. मुंबई
 - 2. नई दिल्ली
 - 3. कोलकाता
 - 4. चेन्नई

Question ID : 264330158471
Option 1 ID : 264330621243
Option 2 ID : 264330621245
Option 3 ID : 264330621244
Option 4 ID : 264330621246
Status : Answered
Chosen Option : 2

Q.33 अंतरराष्ट्रीय आर्थिक शोध पत्रिका, सेंट्रल बैंकिंग द्वारा 2023 के लिए 'गवर्नर ऑफ द ईयर' की उपाधि से किसे सम्मानित किया गया है?

- Ans
- 1. गीता गोपीनाथ
 - 2. शक्तिकांत दास
 - 3. रघुराम राजन
 - 4. उर्जित पटेल

Question ID : 264330158508
Option 1 ID : 264330621394
Option 2 ID : 264330621391
Option 3 ID : 264330621392
Option 4 ID : 264330621393
Status : Answered
Chosen Option : 2

Q.34 भारत के योजना आयोग (2011-12) के अनुसार निम्नलिखित राज्यों को गरीबी रेखा से नीचे की जनसंख्या के प्रतिशत के साथ सुमेलित कीजिए।

राज्य	गरीबी रेखा से नीचे की जनसंख्या का %
1. मिजोरम	a. 20.40
2. नागालैंड	b. 18.88
3. ओडिशा	c. 32.59

- Ans
- 1. 1-b, 2-a, 3-c
 - 2. 1-a, 2-c, 3-b
 - 3. 1-c, 2-b, 3-a
 - 4. 1-a, 2-b, 3-c

Question ID : 264330119918
Option 1 ID : 264330469949
Option 2 ID : 264330469948
Option 3 ID : 264330469950
Option 4 ID : 264330469947
Status : Not Answered
Chosen Option : --

Q.35 आरबीआई (RBI) के प्रथम गवर्नर कौन थे?

- Ans
- 1. सर सी.डी. देशमुख
 - 2. सर ओसबोर्न स्मिथ
 - 3. एच.वी.आर. आयंगर
 - 4. एन.सी. सेन गुप्ता

Question ID : 264330109978

Option 1 ID : 264330432190

Option 2 ID : 264330432191

Option 3 ID : 264330432189

Option 4 ID : 264330432192

Status : Answered

Chosen Option : 3

Q.36 जनवरी 2023 तक प्राप्त जानकारी के अनुसार, गुजरात के/की मुख्यमंत्री कौन हैं?

- Ans
- 1. भूपेश बघेल
 - 2. भूपेंद्र पटेल
 - 3. विजय रुपानी
 - 4. आनंदी पटेल

Question ID : 264330165213

Option 1 ID : 264330647951

Option 2 ID : 264330647954

Option 3 ID : 264330647952

Option 4 ID : 264330647953

Status : Answered

Chosen Option : 1

Q.37 निम्नलिखित में से कौन-सा विकल्प अवसंरचना (इन्फ्रास्ट्रक्चर) क्षेत्र का हिस्सा नहीं है?

- Ans
- 1. राजमार्ग
 - 2. बांध
 - 3. कृषि
 - 4. विद्युत

Question ID : 264330163207

Option 1 ID : 264330640141

Option 2 ID : 264330640139

Option 3 ID : 264330640142

Option 4 ID : 264330640140

Status : Answered

Chosen Option : 3

Q.38 निम्नलिखित में से कौन-सा नृत्य, महाराष्ट्र राज्य का लोक नृत्य है?

- Ans
- 1. गरबा
 - 2. भांगड़ा
 - 3. धनगरी गजा
 - 4. घूमर

Question ID : 264330134246

Option 1 ID : 264330525980

Option 2 ID : 264330525981

Option 3 ID : 264330525982

Option 4 ID : 264330525979

Status : Answered

Chosen Option : 3

Q.39 भारतीय नृत्य में पंडित बिरजू महाराज के योगदान के लिए उनकी उपलब्धियों की सही कालानुक्रमिक व्यवस्था का चयन कीजिए:

- (A) उन्हें फिल्म विश्वरूपम के लिए सर्वश्रेष्ठ कोरियोग्राफी का राष्ट्रीय फिल्म पुरस्कार मिला।
(B) भारतीय नृत्य के प्रति समर्पण के लिए उन्हें पद्म विभूषण से सम्मानित किया गया।
(C) उन्हें फिल्म बाजीराव मस्तानी के लिए सर्वश्रेष्ठ कोरियोग्राफी का फिल्मफेयर पुरस्कार मिला।

- Ans 1. (C), (B), (A)
 2. (A), (C), (B)
 3. (B), (A), (C)
 4. (A), (B), (C)

Question ID : 264330130533
Option 1 ID : 264330511246
Option 2 ID : 264330511245
Option 3 ID : 264330511243
Option 4 ID : 264330511244
Status : Answered
Chosen Option : 2

Q.40 निम्नलिखित में से कौन-सा खाद्य में एक अदृश्य जैविक खतरा है?

- Ans 1. कृमि
 2. घुन
 3. मक्खी
 4. फफूँदी

Question ID : 264330131707
Option 1 ID : 264330515929
Option 2 ID : 264330515928
Option 3 ID : 264330515930
Option 4 ID : 264330515927
Status : Not Answered
Chosen Option : --

Q.41 निम्नलिखित में से कौन-सी प्रदर्शन श्रेणी गुरु केलुचरण महापात्र और गुरु केलुचरण महापात्र युवा प्रतिभा सम्मान से संबंधित है?

- Ans 1. कर्नाटक नृत्य और संगीत
 2. ओडिसी नृत्य और संगीत
 3. मणिपुरी नृत्य और संगीत
 4. महाराष्ट्र नृत्य और संगीत

Question ID : 264330157018
Option 1 ID : 264330615448
Option 2 ID : 264330615447
Option 3 ID : 264330615449
Option 4 ID : 264330615450
Status : Not Answered
Chosen Option : --

Q.42 चेतियागिरी विहार महोत्सव किस राज्य में आयोजित किया जाता है?

- Ans
- 1. त्रिपुरा
 - 2. मध्य प्रदेश
 - 3. तेलंगाना
 - 4. हिमाचल प्रदेश

Question ID : 264330111158
Option 1 ID : 264330436717
Option 2 ID : 264330436720
Option 3 ID : 264330436719
Option 4 ID : 264330436718
Status : Not Answered
Chosen Option : --

Q.43 निम्नलिखित में से किस संगीतकार को प्रसिद्ध बैंड 'द बीटल्स' के साथ कोलैबोरेट करने का श्रेय दिया जाता है?

- Ans
- 1. पंडित रवि शंकर
 - 2. पंडित कुमार गंधर्व
 - 3. पंडित भीमसेन जोशी
 - 4. पंडित शिव कुमार शर्मा

Question ID : 26433064250
Option 1 ID : 264330251592
Option 2 ID : 264330251594
Option 3 ID : 264330251595
Option 4 ID : 264330251593
Status : Not Answered
Chosen Option : --

Q.44 'इंडिया आफ्टर गांधी: द हिस्ट्री ऑफ द वर्ल्ड्स लार्जस्ट डेमोक्रेसी' पुस्तक के लेखक निम्नलिखित में से कौन हैं?

- Ans
- 1. रामचंद्र गुहा
 - 2. रविंदर सिंह
 - 3. अनुजा चौहान
 - 4. संध्या मेनन

Question ID : 26433071712
Option 1 ID : 264330281272
Option 2 ID : 264330281274
Option 3 ID : 264330281273
Option 4 ID : 264330281275
Status : Not Answered
Chosen Option : --

Q.45 निम्नलिखित में से किसे 1860 में ब्रिटिश भारत में अधिनियमित किया गया था?

- Ans
- 1. भारतीय दंड संहिता
 - 2. हिंदू विधवा पुनर्विवाह अधिनियम
 - 3. बंगाल का स्थायी बंदोबस्त
 - 4. भारतीय साक्ष्य अधिनियम

Question ID : 264330111394
Option 1 ID : 264330437661
Option 2 ID : 264330437662
Option 3 ID : 264330437663
Option 4 ID : 264330437664
Status : Not Answered
Chosen Option : --

Q.46 समतापमंडल का विस्तार क्षोभसीमा के ऊपर _____ तक होता है।

- Ans
- 1. 40 km
 - 2. 30 km
 - 3. 60 km
 - 4. 50 km

Question ID : 264330117622

Option 1 ID : 264330462514

Option 2 ID : 264330462513

Option 3 ID : 264330462516

Option 4 ID : 264330462515

Status : Answered

Chosen Option : 1

Q.47 भारतीय संविधान के किस अनुच्छेद में उल्लेख है कि "संघ के लिए एक लोक सेवा आयोग और प्रत्येक राज्य के लिए एक लोक सेवा आयोग होगा"?

- Ans
- 1. 315 (2)
 - 2. 315 (4)
 - 3. 315 (3)
 - 4. 315 (1)

Question ID : 264330133067

Option 1 ID : 264330521320

Option 2 ID : 264330521322

Option 3 ID : 264330521321

Option 4 ID : 264330521319

Status : Answered

Chosen Option : 3

Q.48 निम्नलिखित में से कौन-सी सामान्य अवसादी चट्टानें हैं?

- Ans
- 1. बलुआ पत्थर, चूना पत्थर और स्टेली पत्थर
 - 2. गैर-शल्कित चट्टानें, ग्रेनाइट और स्टेली पत्थर
 - 3. चूना पत्थर, बॉक्साइट और गैर-शल्कित चट्टानें
 - 4. बलुआ पत्थर, बॉक्साइट और शल्कित चट्टानें

Question ID : 264330111918

Option 1 ID : 264330439760

Option 2 ID : 264330439759

Option 3 ID : 264330439758

Option 4 ID : 264330439757

Status : Not Answered

Chosen Option : --

Q.49 बाघ गुफाओं (Bagh caves) पर बने चित्रों का संबंध निम्नलिखित में से किस काल से है?

- Ans
- 1. गुप्त
 - 2. मौर्य
 - 3. मौखरि
 - 4. चोल

Question ID : 264330112143

Option 1 ID : 264330440659

Option 2 ID : 264330440657

Option 3 ID : 264330440660

Option 4 ID : 264330440658

Status : Answered

Chosen Option : 2

Q.50 पीने के पानी की बोतलें और कई अन्य घरेलू सामान बनाने में प्रयुक्त होने वाली कठोर प्लास्टिक में निम्नलिखित में से कौन-सा रासायनिक यौगिक मौजूद होता है?

- Ans
- 1. बिसफेनोल-A
 - 2. ट्रा फ्लुरेन
 - 3. हेप्टाक्लोर
 - 4. क्रोम एलम

Question ID : 264330110094
Option 1 ID : 264330432656
Option 2 ID : 264330432654
Option 3 ID : 264330432655
Option 4 ID : 264330432653
Status : Not Answered
Chosen Option : --

Section : English Language and Comprehension

Q.1 The following sentence has been divided into parts. One of them may contain an error. Select the part that contains the error from the given options. If you don't find any error, mark 'No error' as your answer.

She have been spending / all her money on her flat / to make it more decorative.

- Ans
- 1. No error
 - 2. All her money on her flat
 - 3. To make it more decorative
 - 4. She have been spending

Question ID : 26433091852
Option 1 ID : 264330360748
Option 2 ID : 264330360746
Option 3 ID : 264330360747
Option 4 ID : 264330360745
Status : Answered
Chosen Option : 4

Q.2 Select the option that expresses the given sentence in indirect speech.

She exclaimed delightfully, "What a beautiful sunset!"

- Ans
- 1. She exclaimed that it was a beautiful sunset.
 - 2. She exclaimed delightedly about the sunset.
 - 3. She exclaimed with delight that it was a beautiful sunset.
 - 4. She exclaimed with delight on seeing the beautiful sunset!

Question ID : 264330169743
Option 1 ID : 264330665673
Option 2 ID : 264330665672
Option 3 ID : 264330665671
Option 4 ID : 264330665674
Status : Answered
Chosen Option : 1

Q.3 Select the option that expresses the given sentence in passive voice.
The company is launching a new product next month.

- Ans
- 1. The company will be launching a new product next month.
 - 2. The company is being launching by a new product next month.
 - 3. A new product is being launched by the company next month.
 - 4. A new product would be launched by the company next month.

Question ID : 264330164243
Option 1 ID : 264330644205
Option 2 ID : 264330644206
Option 3 ID : 264330644203
Option 4 ID : 264330644204
Status : Answered
Chosen Option : 2

Q.4 Select the option that can be used as a substitute for the underlined group of words.
Kajal has an inclination for history.

- Ans
- 1. adoptive
 - 2. attitude
 - 3. aptitude
 - 4. altitude

Question ID : 264330117275
Option 1 ID : 264330461160
Option 2 ID : 264330461157
Option 3 ID : 264330461158
Option 4 ID : 264330461159
Status : Answered
Chosen Option : 1

Q.5 Select the option that expresses the given sentence in direct speech.
Teena said that the servant might come the next day.

- Ans
- 1. Teena said, "The servant will come tomorrow."
 - 2. Teena said, "The servant will be coming tomorrow."
 - 3. Teena said, "The servant may come tomorrow."
 - 4. Teena said, "The servant may come today."

Question ID : 264330134210
Option 1 ID : 264330525836
Option 2 ID : 264330525838
Option 3 ID : 264330525837
Option 4 ID : 264330525835
Status : Answered
Chosen Option : 3

Q.6 Select the most appropriate meaning of the underlined idiom.
The old man started to blow his own trumpet at the meeting.

- Ans**
- 1. Talk boastfully about oneself
 - 2. Make fun of
 - 3. Be friendly
 - 4. Support one's cause

Question ID : 264330165285
Option 1 ID : 264330648228
Option 2 ID : 264330648230
Option 3 ID : 264330648229
Option 4 ID : 264330648227
Status : Answered
Chosen Option : 2

Q.7 Select the option that expresses the given sentence in active voice.

These parcels will be delivered later.

- Ans**
- 1. Somebody will be delivered with these parcels later.
 - 2. These parcels will deliver somebody later
 - 3. Somebody will deliver these parcels later.
 - 4. Later, these parcels will deliver somebody.

Question ID : 264330164591
Option 1 ID : 264330645548
Option 2 ID : 264330645547
Option 3 ID : 264330645549
Option 4 ID : 264330645550
Status : Answered
Chosen Option : 3

Q.8 Select the most appropriate meaning of the underlined idiom.
They have been living from hand-to-mouth since they lost their property in that case.

- Ans**
- 1. Awkward situation
 - 2. Come to nothing
 - 3. Have just enough money to spend on basic needs
 - 4. Deal with a troublesome person

Question ID : 264330165286
Option 1 ID : 264330648234
Option 2 ID : 264330648231
Option 3 ID : 264330648233
Option 4 ID : 264330648232
Status : Answered
Chosen Option : 3

Q.9 Select the most appropriate meaning for the given idiom.
Mincing walk

- Ans 1. Small and delicate steps
 2. Big and large house
 3. Show and tell arena
 4. Giant and huge garden

Question ID : 264330168305
Option 1 ID : 264330660084
Option 2 ID : 264330660083
Option 3 ID : 264330660086
Option 4 ID : 264330660085
Status : Answered
Chosen Option : 3

Q.10 Select the most appropriate option that can substitute the underlined segment in the given sentence. If there is no need to substitute it, select 'No substitution required'.

It is easier to learn English than to learn German.

- Ans 1. No substitution required
 2. learning than German
 3. than learn German
 4. not to learn German

Question ID : 264330101275
Option 1 ID : 264330397648
Option 2 ID : 264330397645
Option 3 ID : 264330397646
Option 4 ID : 264330397647
Status : Answered
Chosen Option : 2

Q.11 Select the option that expresses the given sentence in direct speech.
The old man advised him to always speak the truth.

- Ans 1. The old man advised, "Truth be told."
 2. The old man said to him, "Always speak the truth."
 3. "Truth shall always be spoken," advised the old man.
 4. "I advised you to always speak the truth," the old man said.

Question ID : 264330134145
Option 1 ID : 264330525603
Option 2 ID : 264330525604
Option 3 ID : 264330525605
Option 4 ID : 264330525606
Status : Answered
Chosen Option : 2

Q.12 Sentences of a paragraph are given below in jumbled order. Arrange the sentences in the correct order to form a meaningful and coherent paragraph.

- A. Manali Kallat Vainu Bappu is the first Indian astronomer whose name is associated with a comet.
- B. He is the first Indian astronomer whose name is associated with an observatory.
- C. He has the credit of being the first Indian to preside the International Astronomical Union.
- D. He is also associated with an astronomical phenomenon.

- Ans
- 1. ABCD
 - 2. DCBA
 - 3. CDAB
 - 4. BCDA

Question ID : 26433098152
Option 1 ID : 264330385263
Option 2 ID : 264330385264
Option 3 ID : 264330385262
Option 4 ID : 264330385261
Status : Answered
Chosen Option : 1

Q.13 Select the most appropriate option that can substitute the underlined segment in the given sentence.
He ordered for four cups of tea and some snacks.

- Ans
- 1. ordered four for cups of tea
 - 2. ordered four cups of tea
 - 3. order for four cups of tea
 - 4. gave ordered for four cups of tea

Question ID : 264330117270
Option 1 ID : 264330461138
Option 2 ID : 264330461139
Option 3 ID : 264330461140
Option 4 ID : 264330461137
Status : Answered
Chosen Option : 2

Q.14 Select the option that best expresses the meaning of the underlined idiom.
Irene pulled a face when she heard that John was coming for the meeting.

- Ans
- 1. Show that you get on extremely well with someone
 - 2. Show that you do not like something by making an unpleasant expression
 - 3. Show that you are kind and empathetic
 - 4. Show that you are relaxed and in control

Question ID : 264330164685
Option 1 ID : 264330645909
Option 2 ID : 264330645908
Option 3 ID : 264330645910
Option 4 ID : 264330645907
Status : Answered
Chosen Option : 1

Q.15 Select the most appropriate ANTONYM of the given word.
Timorous

- Ans 1. Imbecilic
 2. Muggy
 3. Brazen
 4. Badgered

Question ID : 264330168042
Option 1 ID : 264330659057
Option 2 ID : 264330659058
Option 3 ID : 264330659056
Option 4 ID : 264330659055
Status : Not Answered
Chosen Option : --

Q.16 The following sentence has been split into four segments. Identify the segment that contains a grammatical error.
She sat amid a / rocking chair, listening to / some music and / reminiscing about the past.

- Ans 1. Rocking chair, listening to
 2. Some music and
 3. Reminiscing about the past
 4. She sat amid a

Question ID : 264330133407
Option 1 ID : 264330522660
Option 2 ID : 264330522661
Option 3 ID : 264330522662
Option 4 ID : 264330522659
Status : Answered
Chosen Option : 1

Q.17 Select the most appropriate option that can substitute the underlined segment in the given sentence. If there is no need to substitute it, select 'No substitution'.

Ravina was very sick today, and we will take her to the hospital as she gets worse.

- Ans 1. we took her to the hospital now before she gets worse
 2. No substitution
 3. we can take her to the hospital now before she get worse
 4. we will take her to the hospital now before she gets worse

Question ID : 264330101026
Option 1 ID : 264330396651
Option 2 ID : 264330396652
Option 3 ID : 264330396650
Option 4 ID : 264330396649
Status : Answered
Chosen Option : 2

Q.18 Select the most appropriate option that can substitute the underlined segment in the given sentence. If there is no need to substitute it, select 'No substitution.'
She is the eldest member of our town.

- Ans
- 1. No substitution
 - 2. is the elder
 - 3. is the old
 - 4. is the oldest

Question ID : 264330120520
Option 1 ID : 264330472334
Option 2 ID : 264330472331
Option 3 ID : 264330472333
Option 4 ID : 264330472332
Status : Answered
Chosen Option : 4

Q.19 Select the most appropriate option that can substitute the underlined segment in the given sentence.
The manager of the hotel requested the boarder to mention his whereabouts in the register.

- Ans
- 1. aftermath of the offence
 - 2. reason of moral degradation
 - 3. place of residence
 - 4. motif of the heinous crime

Question ID : 264330117045
Option 1 ID : 264330460262
Option 2 ID : 264330460263
Option 3 ID : 264330460264
Option 4 ID : 264330460261
Status : Answered
Chosen Option : 2

Q.20 The following sentence has been divided into parts. One of them may contain an error. Select the part that contains the error from the given options. If you don't find any error, mark 'No error' as your answer.

You must meet / Suyash sometime. / I think you like him.

- Ans
- 1. You must meet
 - 2. I think you like him
 - 3. No error
 - 4. Suyash sometime

Question ID : 264330120569
Option 1 ID : 264330472519
Option 2 ID : 264330472520
Option 3 ID : 264330472522
Option 4 ID : 264330472521
Status : Answered
Chosen Option : 1

Q.21 Select the option that expresses the given sentence in passive voice.
Nandita was seeking a good research area where she could prepare a good proposal for submission.

- Ans**
- 1. A good research area was sought by Nandita where a good proposal could have prepared by her for submission.
 - 2. A good research area was being sought by Nandita where a good proposal could be prepared by her for submission.
 - 3. A good research area had been sought by Nandita where a good proposal could have been prepared by her for submission.
 - 4. A good research area were sought by Nandita where a good proposal could prepare by her for submission.

Question ID : 264330136991
Option 1 ID : 264330536615
Option 2 ID : 264330536616
Option 3 ID : 264330536617
Option 4 ID : 264330536618
Status : Answered
Chosen Option : 2

Q.22 Select the option that expresses the given sentence in direct speech.

Louise said that it was getting late.

- Ans**
- 1. Louise said, "It gets late."
 - 2. Louise said, "It was got late."
 - 3. Louise said, "It got late."
 - 4. Louise said, "It is getting late."

Question ID : 264330163324
Option 1 ID : 264330640597
Option 2 ID : 264330640598
Option 3 ID : 264330640596
Option 4 ID : 264330640595
Status : Answered
Chosen Option : 4

Q.23 Sentences of a paragraph are given below in jumbled order. Arrange the sentences in the correct order to form a meaningful and coherent paragraph.

- A. Archaeologists are guys who have been meticulously excavating.
- B. These people go through thick layers of dirt to investigate human artefacts, particularly those from the prehistoric era.
- C. They have discovered old city ruins, strewn tools, and writing and pottery shards.
- D. In an effort to find the solutions to numerous problems, they have attempted to put all these hints together like a huge jigsaw puzzle.

- Ans**
- 1. BDAC
 - 2. ABCD
 - 3. CBAD
 - 4. DCAB

Question ID : 26433098145
Option 1 ID : 264330385233
Option 2 ID : 264330385234
Option 3 ID : 264330385235
Option 4 ID : 264330385236
Status : Answered
Chosen Option : 2

Q.24 Select the most appropriate option that can substitute the underlined segment in the given sentence.

Police termed it as of riot on which two of their colleagues were killed and many spectators got injured.

- Ans
- 1. as a riot though which two of their
 - 2. as a riot for which two of their
 - 3. as a riot in which two of their
 - 4. as if riot about which two of their

Question ID : 264330100996
Option 1 ID : 264330396532
Option 2 ID : 264330396529
Option 3 ID : 264330396530
Option 4 ID : 264330396531
Status : Answered
Chosen Option : 4

Q.25 Select the most appropriate synonym of the given word.
Exactly

- Ans
- 1. Privately
 - 2. Torridly
 - 3. Precisely
 - 4. Costly

Question ID : 264330164270
Option 1 ID : 264330644304
Option 2 ID : 264330644305
Option 3 ID : 264330644303
Option 4 ID : 264330644306
Status : Answered
Chosen Option : 3

Q.26 The following sentence has been split into four segments. Identify the segment that contains a grammatical error.
The CEO announced that / the company's profits has / fallen significantly / in the last quarter.

- Ans
- 1. fallen significantly
 - 2. The CEO announced that
 - 3. in the last quarter
 - 4. the company's profits has

Question ID : 264330137469
Option 1 ID : 264330538497
Option 2 ID : 264330538495
Option 3 ID : 264330538498
Option 4 ID : 264330538496
Status : Answered
Chosen Option : 4

Q.27 Select the option that expresses the given sentence in passive voice.
The guard refused him admittance.

- Ans
- 1. He is refused admittance by guard.
 - 2. Admittance was refused.
 - 3. Admittance wasn't given to him by the guard.
 - 4. He was refused admittance by the guard.

Question ID : 264330134137
Option 1 ID : 264330525574
Option 2 ID : 264330525573
Option 3 ID : 264330525571
Option 4 ID : 264330525572
Status : Answered
Chosen Option : 4

Q.28 Select the most appropriate synonym of the given word.
Glorious

- Ans
- 1. Dull
 - 2. Splendid
 - 3. Immense
 - 4. Keen

Question ID : 264330164164
Option 1 ID : 264330643907
Option 2 ID : 264330643910
Option 3 ID : 264330643908
Option 4 ID : 264330643909
Status : Answered
Chosen Option : 2

Q.29 Select the most appropriate ANTONYM of the given word.

Nominal

- Ans
- 1. Identical
 - 2. Excessive
 - 3. Liberal
 - 4. Adroit

Question ID : 264330141551
Option 1 ID : 264330554539
Option 2 ID : 264330554542
Option 3 ID : 264330554541
Option 4 ID : 264330554540
Status : Answered
Chosen Option : 3

Q.30 Select the option that expresses the given sentence in passive voice.
Do not make noise in the classroom.

- Ans
- 1. Noise should not be made by you in the classroom.
 - 2. Noise better not be made by you in the classroom.
 - 3. Noise should not have been made by you in the classroom.
 - 4. Noise cannot be made by you in the classroom.

Question ID : 264330164370
Option 1 ID : 264330644693
Option 2 ID : 264330644692
Option 3 ID : 264330644694
Option 4 ID : 264330644691
Status : Answered
Chosen Option : 1

Q.31 Select the most appropriate option to substitute the underlined segment in the given sentence.

Either my sisters or my brother are coming to the meeting.

- Ans
- 1. my brother come
 - 2. my brother is coming
 - 3. my brother do not come
 - 4. my brothers is coming

Question ID : 264330100293
Option 1 ID : 264330393738
Option 2 ID : 264330393739
Option 3 ID : 264330393740
Option 4 ID : 264330393737
Status : Answered
Chosen Option : 2

Q.32 The following sentence has been split into four segments. Identify the segment that contains a grammatical error.

He bought a / pen; a / pen was silver / grey in colour.

- Ans
- 1. grey in colour
 - 2. pen; a
 - 3. pen was silver
 - 4. He bought a

Question ID : 264330137223
Option 1 ID : 264330537526
Option 2 ID : 264330537524
Option 3 ID : 264330537525
Option 4 ID : 264330537523
Status : Answered
Chosen Option : 2

Q.33 Select the option that expresses the given sentence in reported speech.
He said, "I will go and return quickly."

- Ans**
- 1. He said that he would go and return quickly.
 - 2. He said that he will gone and returned quickly.
 - 3. He said that I would go and return quickly.
 - 4. He said that he would go and I will return quickly.

Question ID : 264330139358
Option 1 ID : 264330545900
Option 2 ID : 264330545901
Option 3 ID : 264330545902
Option 4 ID : 264330545899
Status : Answered
Chosen Option : 1

Q.34 The following sentence has been split into four segments. Identify the segment that contains a grammatical error.

Shops are not allowed / to remain open / after 8:00 pm / from the lockdown.

- Ans**
- 1. to remain open
 - 2. after 8:00 pm
 - 3. from the lockdown.
 - 4. Shops are not allowed

Question ID : 26433096154
Option 1 ID : 264330377386
Option 2 ID : 264330377387
Option 3 ID : 264330377388
Option 4 ID : 264330377385
Status : Answered
Chosen Option : 1

Q.35 The following sentence has been split into four segments. Identify the segment that contains a grammatical error.

As twilight settled / upon the bustling city, / its streets come alive with / a symphony of flickering lights.

- Ans**
- 1. upon the bustling city
 - 2. As twilight settled
 - 3. a symphony of flickering lights
 - 4. its streets come alive with

Question ID : 264330164566
Option 1 ID : 264330645452
Option 2 ID : 264330645451
Option 3 ID : 264330645454
Option 4 ID : 264330645453
Status : Answered
Chosen Option : 1

Q.36 In the following questions a statement has been given with highlighted text. Select the options that can replace the text with correct idiom or phrase.
The judge was extremely angry at the attitude of the culprit.

- Ans 1. Play by the ear
 2. Make one's blood boil
 3. Back to the drawing board
 4. Throw caution to the wind

Question ID : 264330120755
Option 1 ID : 264330473236
Option 2 ID : 264330473237
Option 3 ID : 264330473238
Option 4 ID : 264330473235
Status : Answered
Chosen Option : 2

Q.37 Select the idiom that best describes the underlined segment.
You shouldn't stress much. This unpleasant situation could be hiding something positive in it.

- Ans 1. over the moon
 2. on cloud nine
 3. hit the nail on the head
 4. every cloud has a silver lining

Question ID : 264330122287
Option 1 ID : 264330479274
Option 2 ID : 264330479273
Option 3 ID : 264330479272
Option 4 ID : 264330479271
Status : Answered
Chosen Option : 4

Q.38 Select the most appropriate ANTONYM of the given word.
Decadent

- Ans 1. Fluorescent
 2. Virtuous
 3. Muffled
 4. Enflamed

Question ID : 264330168040
Option 1 ID : 264330659048
Option 2 ID : 264330659047
Option 3 ID : 264330659049
Option 4 ID : 264330659050
Status : Not Answered
Chosen Option : --

Q.39 Select the option that expresses the given sentence in passive voice.
The teacher gave the assignments to the students.

- Ans 1. The students were given the assignments by the teacher.
 2. The students are given the assignments.
 3. The teacher was given assignments to the students.
 4. The students had been given the assignments.

Question ID : 264330168246
Option 1 ID : 264330659857
Option 2 ID : 264330659855
Option 3 ID : 264330659858
Option 4 ID : 264330659856
Status : Answered
Chosen Option : 1

Q.40 Select the most appropriate ANTONYM of the given word.
Frequent

- Ans 1. Persistent
 2. Rare
 3. Constant
 4. Recurring

Question ID : 264330168137
Option 1 ID : 264330659424
Option 2 ID : 264330659426
Option 3 ID : 264330659423
Option 4 ID : 264330659425
Status : Answered
Chosen Option : 2

Q.41 Select the most appropriate synonym of the given word.
Adequate

- Ans 1. Ancient
 2. Sufficient
 3. Competent
 4. Efficient

Question ID : 264330168264
Option 1 ID : 264330659924
Option 2 ID : 264330659923
Option 3 ID : 264330659925
Option 4 ID : 264330659926
Status : Not Answered
Chosen Option : --

Q.42 Select the most appropriate option that can substitute the underlined segment in the given sentence.

They didn't catch you, are they?

- Ans
- 1. didn't they
 - 2. did they
 - 3. had they
 - 4. wasn't it

Question ID : 264330117161
Option 1 ID : 264330460712
Option 2 ID : 264330460709
Option 3 ID : 264330460710
Option 4 ID : 264330460711
Status : Answered
Chosen Option : 2

Q.43 Select the most appropriate option that can substitute the underlined segment in the given sentence.

The road has been rough, they abandoned their journey further.

- Ans
- 1. be rough
 - 2. being rough
 - 3. was rough
 - 4. had been rough

Question ID : 264330133430
Option 1 ID : 264330522754
Option 2 ID : 264330522753
Option 3 ID : 264330522751
Option 4 ID : 264330522752
Status : Answered
Chosen Option : 4

Q.44 Sentences of a paragraph are given below in jumbled order. Arrange the sentences in the correct order to form a meaningful and coherent paragraph.

- A.The use of graphics helps in simplifying complicated concepts in subjects such as mathematics, biophysics, molecular biology and quantum mechanics.
- B.Visual materials can also aid in the comprehension and elaboration of a learning segment.
- C.Graphic images enhance students' motivation and interest while also speeding up learning.
- D.The internet provides students with a range of visual elements and does not limit them to a single individual's interpretation.

- Ans
- 1. ACBD
 - 2. DABC
 - 3. CBDA
 - 4. DCBA

Question ID : 26433070570
Option 1 ID : 264330276752
Option 2 ID : 264330276754
Option 3 ID : 264330276755
Option 4 ID : 264330276753
Status : Answered
Chosen Option : 2

Q.45 Select the option that expresses the following sentence in active voice.
Ankur answered all the questions correctly in the interview.

- Ans 1. All the questions were answered correctly by Ankur in the interview.
 2. In the interview all the questions are answered correctly by Ankur
 3. All the questions had been answered correctly by Ankur in the interview.
 4. All the questions have been answered correctly by Ankur in the interview.

Question ID : 264330164321
Option 1 ID : 264330644500
Option 2 ID : 264330644499
Option 3 ID : 264330644502
Option 4 ID : 264330644501
Status : Answered
Chosen Option : 1

Q.46 Select the option that contains a grammatical error in the underlined portion.

I didn't sleep well last night because the dog is barking.

- Ans 1. I didn't sleep well last night because the dog is barking.
 2. I didn't sleep well last night because the dog is barking.
 3. I didn't sleep well last night because the dog is barking.
 4. I didn't sleep well last night because the dog is barking.

Question ID : 26433088598
Option 1 ID : 264330347961
Option 2 ID : 264330347964
Option 3 ID : 264330347962
Option 4 ID : 264330347963
Status : Answered
Chosen Option : 2

Q.47 Select the most appropriate preposition to fill in the blank.
The boy jumped _____ the sofa.

- Ans 1. in
 2. of
 3. on
 4. below

Question ID : 264330164311
Option 1 ID : 264330644461
Option 2 ID : 264330644459
Option 3 ID : 264330644460
Option 4 ID : 264330644462
Status : Answered
Chosen Option : 1

Q.48 You are discussing the poor actions of a colleague. Select a synonym for the highlighted word.

She was often oblivious to the potential consequences of her actions.

- Ans
- 1. obvious
 - 2. unaware
 - 3. proficient
 - 4. barely

Question ID : 264330123060
Option 1 ID : 264330482303
Option 2 ID : 264330482306
Option 3 ID : 264330482304
Option 4 ID : 264330482305
Status : Answered
Chosen Option : 2

Q.49 Select the most appropriate option to substitute the underlined segment in the given sentence.

The knowledge and abilities that students are expected to master as they progress through the four years of high school are referred to as the high school curriculum.

- Ans
- 1. advance through
 - 2. deteriorate over
 - 3. grow with
 - 4. regress along

Question ID : 264330117339
Option 1 ID : 264330461409
Option 2 ID : 264330461411
Option 3 ID : 264330461410
Option 4 ID : 264330461412
Status : Answered
Chosen Option : 3

Q.50 Sentences of a paragraph are given below in jumbled order. Arrange the sentences in the correct order to form a meaningful and coherent paragraph.

- A. Many experts recommend that you exercise for 30 minutes every day, 5-6 days a week.
- B. Regular exercise is one of the most effective and simple ways to maintain a healthy lifestyle.
- C. Something as basic as 30 minutes of brisk walking or stretching can add several healthy years to your life.
- D. Regular exercise can help you manage your weight, build your bones and muscles, and lower your risk of diabetes, heart disease and stroke.

- Ans
- 1. DCBA
 - 2. DBCA
 - 3. ACBD
 - 4. BDAC

Question ID : 26433097527
Option 1 ID : 264330382782
Option 2 ID : 264330382784
Option 3 ID : 264330382781
Option 4 ID : 264330382783
Status : Answered
Chosen Option : 3

Q.51 Select the most appropriate option to fill in the blank.

My friend borrowed a large sum from me for investment in stocks but so far he hasn't had any considerable _____.

- Ans
- 1. profit
 - 2. money
 - 3. fund
 - 4. sum

Question ID : 26433098901
Option 1 ID : 264330388258
Option 2 ID : 264330388259
Option 3 ID : 264330388260
Option 4 ID : 264330388257
Status : Answered
Chosen Option : 1

Q.52 Select the most appropriate ANTONYM of the given word.
Frenzy

- Ans
- 1. Copious
 - 2. Harmony
 - 3. Haste
 - 4. Obscurity

Question ID : 264330168039
Option 1 ID : 264330659046
Option 2 ID : 264330659045
Option 3 ID : 264330659043
Option 4 ID : 264330659044
Status : Answered
Chosen Option : 1

Q.53 Select the most appropriate option that can substitute the underlined segment in the given sentence.
When the thief sees the sentry at the main gate, he managed to escape from the side gate.

- Ans
- 1. has seen the sentry
 - 2. see the sentry
 - 3. seeing the sentry
 - 4. saw the sentry

Question ID : 264330122262
Option 1 ID : 264330479181
Option 2 ID : 264330479179
Option 3 ID : 264330479180
Option 4 ID : 264330479182
Status : Answered
Chosen Option : 3

Q.54 Select the option that expresses the given sentence in passive voice.
I await your response.

- Ans
- 1. Your response have been awaited.
 - 2. Your response had been awaited.
 - 3. Your response was awaited.
 - 4. Your response is awaited.

Question ID : 264330137232
Option 1 ID : 264330537562
Option 2 ID : 264330537560
Option 3 ID : 264330537559
Option 4 ID : 264330537561
Status : Answered
Chosen Option : 3

Q.55 Select the most appropriate option to fill in the blank.
Knowing that building the new park in the city centre would be a controversial issue,
the mayor's office decided to let the public _____ with their concerns.

- Ans
- 1. size up
 - 2. beat to
 - 3. fill up
 - 4. weigh in

Question ID : 264330134152
Option 1 ID : 264330525633
Option 2 ID : 264330525632
Option 3 ID : 264330525634
Option 4 ID : 264330525631
Status : Answered
Chosen Option : 1

Q.56 Select the option that expresses the following sentence in direct speech.
Harish says that there is going to be a snowfall.

- Ans
- 1. Harish says, "There is going to be a snowfall."
 - 2. Harish says, "There will be going to be a snowfall."
 - 3. Harish says, "There was going to be a snowfall."
 - 4. Harish says, "There may be a snowfall."

Question ID : 264330164350
Option 1 ID : 264330644614
Option 2 ID : 264330644611
Option 3 ID : 264330644612
Option 4 ID : 264330644613
Status : Answered
Chosen Option : 3

Q.57 Select the option that expresses the given sentence in passive voice.
She bakes the cake.

- Ans
- 1. The cake had baked by her.
 - 2. The cake is baked by her.
 - 3. The cake has baked by her.
 - 4. The cake will bake her.

Question ID : 264330168245
Option 1 ID : 264330659853
Option 2 ID : 264330659852
Option 3 ID : 264330659851
Option 4 ID : 264330659854
Status : Answered
Chosen Option : 2

Q.58 Select the most appropriate synonym of the given word.
Principal

- Ans
- 1. Minor
 - 2. Flawless
 - 3. Major
 - 4. Believable

Question ID : 264330168270
Option 1 ID : 264330659948
Option 2 ID : 264330659950
Option 3 ID : 264330659947
Option 4 ID : 264330659949
Status : Answered
Chosen Option : 4

Q.59 Select the most appropriate synonym of the given word.
Feeble

- Ans
- 1. Rugged
 - 2. Stalwart
 - 3. Stout
 - 4. Wimpy

Question ID : 264330137241
Option 1 ID : 264330537598
Option 2 ID : 264330537596
Option 3 ID : 264330537597
Option 4 ID : 264330537595
Status : Answered
Chosen Option : 2

Q.60 The following sentence has been split into four segments. Identify the segment that contains a grammatical error.

I don't think / I can go throughout / the process of raising / two children on my own.

- Ans
- 1. Two children on my own
 - 2. I don't think
 - 3. The process of raising
 - 4. I can go throughout

Question ID : 264330133406

Option 1 ID : 264330522658

Option 2 ID : 264330522655

Option 3 ID : 264330522657

Option 4 ID : 264330522656

Status : Answered

Chosen Option : 4

Q.61 Select the option that expresses the given sentence in indirect speech.
Sonia said, "I have finished my meal."

- Ans
- 1. Sonia said that she had finished her meal.
 - 2. Sonia said that she had finished my meal.
 - 3. Sonia said that she has finished her meal.
 - 4. Sonia said that she has finished my meal.

Question ID : 264330164293

Option 1 ID : 264330644390

Option 2 ID : 264330644388

Option 3 ID : 264330644389

Option 4 ID : 264330644387

Status : Answered

Chosen Option : 1

Q.62 Select the option that expresses the following sentence in direct speech.
She told me that she would come to the party.

- Ans
- 1. She said, "I have to come to the party."
 - 2. She said, "I am coming to the party."
 - 3. She said, "I will come to the party."
 - 4. She said, "I was coming to the party."

Question ID : 264330164640

Option 1 ID : 264330645740

Option 2 ID : 264330645741

Option 3 ID : 264330645739

Option 4 ID : 264330645742

Status : Answered

Chosen Option : 3

Q.63 Select the most appropriate option to fill in the blank.
As the company's client base grew at an unexpected rate, management was forced to _____ some work until they could hire new staff.

- Ans
- 1. dish out
 - 2. man up
 - 3. farm out
 - 4. rat out

Question ID : 264330134151
Option 1 ID : 264330525627
Option 2 ID : 264330525628
Option 3 ID : 264330525629
Option 4 ID : 264330525630
Status : Answered
Chosen Option : 3

Q.64 Select the option that expresses the given sentence in direct speech.
Shalini exclaimed that the painting was enchanting.

- Ans
- 1. Shalini said, "Such an enchanting painting this is!"
 - 2. Shalini exclaimed, "Ahha! Look at the paintings!"
 - 3. "Oh! What a painting!" thought Shalini.
 - 4. "The painting was enchanting," said Shalini.

Question ID : 264330134144
Option 1 ID : 264330525601
Option 2 ID : 264330525602
Option 3 ID : 264330525600
Option 4 ID : 264330525599
Status : Answered
Chosen Option : 1

Q.65 Sentences of a paragraph are given below. While the first and the last sentences (S1 and S6) are in the correct order, the sentences in between are jumbled up. Arrange the sentences in the correct order to form a meaningful and coherent paragraph.
S1. Development should include both material and non-material aspects of human existence.
A. But such development depletes renewable resources and adversely affects environment.
B. In the West, development is totally money-oriented.
C. Only the development which meets the needs of the present generation without disabling the future generations can be called sustainable.
D. This kind of development is not sustainable.
S6. Sustainable development is a positive attitude towards socio-economic problems with a wide involvement of the people.

- Ans
- 1. ADBC
 - 2. BADC
 - 3. BCDA
 - 4. ACBD

Question ID : 264330117462
Option 1 ID : 264330461877
Option 2 ID : 264330461878
Option 3 ID : 264330461880
Option 4 ID : 264330461879
Status : Answered
Chosen Option : 3

Comprehension:

In the following passage, some words have been deleted. Read the passage carefully and select the most appropriate option to fill in each blank.

The concept of (1)_____ refers to the ability of an organism to change in response to its environment. Adaptation can occur through (2)_____, which involves genetic changes passed down from one generation to the next, or (3)_____ ontogeny, which involves changes in an individual's lifetime. Adaptation is a fundamental concept in biology, and it plays a crucial role in the (4)_____ of species over time. Organisms that are well-adapted (5)_____ their environment are more likely to survive and pass on their genes to future generations.

SubQuestion No : 66**Q.66** Select the most appropriate option to fill in blank 1.

- Ans 1. ecology
 2. adaptation
 3. genetics
 4. evolution

Question ID : 264330165121

Option 1 ID : 264330647600

Option 2 ID : 264330647601

Option 3 ID : 264330647602

Option 4 ID : 264330647599

Status : Answered

Chosen Option : 2

Comprehension:

In the following passage, some words have been deleted. Read the passage carefully and select the most appropriate option to fill in each blank.

The concept of (1)_____ refers to the ability of an organism to change in response to its environment. Adaptation can occur through (2)_____, which involves genetic changes passed down from one generation to the next, or (3)_____ ontogeny, which involves changes in an individual's lifetime. Adaptation is a fundamental concept in biology, and it plays a crucial role in the (4)_____ of species over time. Organisms that are well-adapted (5)_____ their environment are more likely to survive and pass on their genes to future generations.

SubQuestion No : 67**Q.67** Select the most appropriate option to fill in blank 2.

- Ans 1. modification
 2. conditioning
 3. mutation
 4. learning

Question ID : 264330165122

Option 1 ID : 264330647603

Option 2 ID : 264330647604

Option 3 ID : 264330647606

Option 4 ID : 264330647605

Status : Answered

Chosen Option : 1

Comprehension:

In the following passage, some words have been deleted. Read the passage carefully and select the most appropriate option to fill in each blank.

The concept of (1)_____ refers to the ability of an organism to change in response to its environment. Adaptation can occur through (2)_____, which involves genetic changes passed down from one generation to the next, or (3)_____ ontogeny, which involves changes in an individual's lifetime. Adaptation is a fundamental concept in biology, and it plays a crucial role in the (4)_____ of species over time. Organisms that are well-adapted (5)_____ their environment are more likely to survive and pass on their genes to future generations.

SubQuestion No : 68**Q.68** Select the most appropriate option to fill in blank 3.

- Ans 1. through
 2. by
 3. from
 4. since

Question ID : 264330165123

Option 1 ID : 264330647607

Option 2 ID : 264330647608

Option 3 ID : 264330647609

Option 4 ID : 264330647610

Status : Answered

Chosen Option : 2

Comprehension:

In the following passage, some words have been deleted. Read the passage carefully and select the most appropriate option to fill in each blank.

The concept of (1)_____ refers to the ability of an organism to change in response to its environment. Adaptation can occur through (2)_____, which involves genetic changes passed down from one generation to the next, or (3)_____ ontogeny, which involves changes in an individual's lifetime. Adaptation is a fundamental concept in biology, and it plays a crucial role in the (4)_____ of species over time. Organisms that are well-adapted (5)_____ their environment are more likely to survive and pass on their genes to future generations.

SubQuestion No : 69**Q.69** Select the most appropriate option to fill in blank 4.

- Ans 1. classification
 2. extinction
 3. management
 4. diversification

Question ID : 264330165124

Option 1 ID : 264330647614

Option 2 ID : 264330647612

Option 3 ID : 264330647613

Option 4 ID : 264330647611

Status : Answered

Chosen Option : 3

Comprehension:

In the following passage, some words have been deleted. Read the passage carefully and select the most appropriate option to fill in each blank.

The concept of (1)_____ refers to the ability of an organism to change in response to its environment. Adaptation can occur through (2)_____, which involves genetic changes passed down from one generation to the next, or (3)_____ ontogeny, which involves changes in an individual's lifetime. Adaptation is a fundamental concept in biology, and it plays a crucial role in the (4)_____ of species over time. Organisms that are well-adapted (5)_____ their environment are more likely to survive and pass on their genes to future generations.

SubQuestion No : 70**Q.70** Select the most appropriate option to fill in blank 5.

- Ans
- 1. towards
 - 2. of
 - 3. to
 - 4. in

Question ID : 264330165125

Option 1 ID : 264330647617

Option 2 ID : 264330647615

Option 3 ID : 264330647616

Option 4 ID : 264330647618

Status : Answered

Chosen Option : 2

Comprehension:

In the following passage, some words have been deleted. Read the passage carefully and select the most appropriate option to fill in each blank.

The newspapers are the (1)_____ of day-to-day happenings in the world. They add to our (2)_____ not only about our own country but also about world affairs. The newspapers also express their opinions about social and political problems through their (3)_____. They mould the readers into their own way of thinking. That is why the newspaper is considered a source of (4)_____. In a democracy, the press is a link between the government and the people. It gives news as to what the government is doing. It reflects public opinion as well. It teaches the citizens their rights and (5)_____.

SubQuestion No : 71**Q.71** Select the most appropriate option to fill in blank number 1.

- Ans
- 1. location
 - 2. warehouse
 - 3. storehouse
 - 4. habitat

Question ID : 264330165255

Option 1 ID : 264330648113

Option 2 ID : 264330648112

Option 3 ID : 264330648111

Option 4 ID : 264330648114

Status : Answered

Chosen Option : 3

Comprehension:

In the following passage, some words have been deleted. Read the passage carefully and select the most appropriate option to fill in each blank.

The newspapers are the (1)_____ of day-to-day happenings in the world. They add to our (2)_____ not only about our own country but also about world affairs. The newspapers also express their opinions about social and political problems through their (3)_____. They, mould the readers into their own way of thinking. That is why the newspaper is considered a source of (4)_____. In a democracy, the press is a link between the government and the people. It gives news as to what the government is doing. It reflects public opinion as well. It teaches the citizens their rights and (5)_____.

SubQuestion No : 72

Q.72 Select the most appropriate option to fill in blank number 2.

- Ans
- 1. senses
 - 2. knowledge
 - 3. enjoyment
 - 4. declaration

Question ID : 264330165256

Option 1 ID : 264330648118

Option 2 ID : 264330648117

Option 3 ID : 264330648115

Option 4 ID : 264330648116

Status : Answered

Chosen Option : 2

Comprehension:

In the following passage, some words have been deleted. Read the passage carefully and select the most appropriate option to fill in each blank.

The newspapers are the (1)_____ of day-to-day happenings in the world. They add to our (2)_____ not only about our own country but also about world affairs. The newspapers also express their opinions about social and political problems through their (3)_____. They, mould the readers into their own way of thinking. That is why the newspaper is considered a source of (4)_____. In a democracy, the press is a link between the government and the people. It gives news as to what the government is doing. It reflects public opinion as well. It teaches the citizens their rights and (5)_____.

SubQuestion No : 73

Q.73 Select the most appropriate option to fill in blank number 3.

- Ans
- 1. editorials
 - 2. thoughts
 - 3. research
 - 4. design

Question ID : 264330165257

Option 1 ID : 264330648121

Option 2 ID : 264330648122

Option 3 ID : 264330648120

Option 4 ID : 264330648119

Status : Answered

Chosen Option : 2

Comprehension:

In the following passage, some words have been deleted. Read the passage carefully and select the most appropriate option to fill in each blank.

The newspapers are the (1)_____ of day-to-day happenings in the world. They add to our (2)_____ not only about our own country but also about world affairs. The newspapers also express their opinions about social and political problems through their (3)_____. They, mould the readers into their own way of thinking. That is why the newspaper is considered a source of (4)_____. In a democracy, the press is a link between the government and the people. It gives news as to what the government is doing. It reflects public opinion as well. It teaches the citizens their rights and (5)_____.

SubQuestion No : 74

Q.74 Select the most appropriate option to fill in blank number 4.

- Ans 1. entertainment
 2. power
 3. refinement
 4. enchantment

Question ID : 264330165258

Option 1 ID : 264330648125

Option 2 ID : 264330648126

Option 3 ID : 264330648123

Option 4 ID : 264330648124

Status : Answered

Chosen Option : 2

Comprehension:

In the following passage, some words have been deleted. Read the passage carefully and select the most appropriate option to fill in each blank.

The newspapers are the (1)_____ of day-to-day happenings in the world. They add to our (2)_____ not only about our own country but also about world affairs. The newspapers also express their opinions about social and political problems through their (3)_____. They, mould the readers into their own way of thinking. That is why the newspaper is considered a source of (4)_____. In a democracy, the press is a link between the government and the people. It gives news as to what the government is doing. It reflects public opinion as well. It teaches the citizens their rights and (5)_____.

SubQuestion No : 75

Q.75 Select the most appropriate option to fill in blank number 5.

- Ans 1. remedies
 2. responsibilities
 3. range
 4. regulations

Question ID : 264330165259

Option 1 ID : 264330648130

Option 2 ID : 264330648129

Option 3 ID : 264330648128

Option 4 ID : 264330648127

Status : Answered

Chosen Option : 2

Comprehension:

In the following passage, some words have been deleted. Fill in the blanks with the help of the alternatives given. Select the most appropriate option for each number.

(1)_____ need for school education reform is impossible to deny on countless fronts in India, from the rule of rote that's suboptimal for (2)_____, to pedagogies that instil fear of math (3)_____ students, especially girls. But while ideating reforms, education policymakers should remember what past experiments (4)_____ them. Remember CCE, continuous and comprehensive evaluation, which was ushered in with hosannas in 2009 but unceremoniously kicked out in 2017. All the turmoil and toil it (5)_____ amounted to zilch in the end. Good idea, poor execution, its epitaph reads.

SubQuestion No : 76

Q.76 Select the most appropriate option to fill in blank no. 1.

- Ans 1. In
 2. A
 3. The
 4. An

Question ID : 264330168286

Option 1 ID : 264330660010

Option 2 ID : 264330660007

Option 3 ID : 264330660008

Option 4 ID : 264330660009

Status : Answered

Chosen Option : 3

Comprehension:

In the following passage, some words have been deleted. Fill in the blanks with the help of the alternatives given. Select the most appropriate option for each number.

(1)_____ need for school education reform is impossible to deny on countless fronts in India, from the rule of rote that's suboptimal for (2)_____, to pedagogies that instil fear of math (3)_____ students, especially girls. But while ideating reforms, education policymakers should remember what past experiments (4)_____ them. Remember CCE, continuous and comprehensive evaluation, which was ushered in with hosannas in 2009 but unceremoniously kicked out in 2017. All the turmoil and toil it (5)_____ amounted to zilch in the end. Good idea, poor execution, its epitaph reads.

SubQuestion No : 77

Q.77 Select the most appropriate option to fill in blank no. 2.

- Ans 1. learned
 2. be learnt
 3. learn
 4. learning

Question ID : 264330168287

Option 1 ID : 264330660013

Option 2 ID : 264330660014

Option 3 ID : 264330660012

Option 4 ID : 264330660011

Status : Answered

Chosen Option : 4

Comprehension:

In the following passage, some words have been deleted. Fill in the blanks with the help of the alternatives given. Select the most appropriate option for each number.

(1)_____ need for school education reform is impossible to deny on countless fronts in India, from the rule of rote that's suboptimal for (2)_____, to pedagogies that instil fear of math (3)_____ students, especially girls. But while ideating reforms, education policymakers should remember what past experiments (4)_____ them. Remember CCE, continuous and comprehensive evaluation, which was ushered in with hosannas in 2009 but unceremoniously kicked out in 2017. All the turmoil and toil it (5)_____ amounted to zilch in the end. Good idea, poor execution, its epitaph reads.

SubQuestion No : 78

Q.78 Select the most appropriate option to fill in blank no. 3.

- Ans
- 1. on
 - 2. of
 - 3. between
 - 4. among

Question ID : 264330168288

Option 1 ID : 264330660015

Option 2 ID : 264330660018

Option 3 ID : 264330660016

Option 4 ID : 264330660017

Status : Answered

Chosen Option : 4

Comprehension:

In the following passage, some words have been deleted. Fill in the blanks with the help of the alternatives given. Select the most appropriate option for each number.

(1)_____ need for school education reform is impossible to deny on countless fronts in India, from the rule of rote that's suboptimal for (2)_____, to pedagogies that instil fear of math (3)_____ students, especially girls. But while ideating reforms, education policymakers should remember what past experiments (4)_____ them. Remember CCE, continuous and comprehensive evaluation, which was ushered in with hosannas in 2009 but unceremoniously kicked out in 2017. All the turmoil and toil it (5)_____ amounted to zilch in the end. Good idea, poor execution, its epitaph reads.

SubQuestion No : 79

Q.79 Select the most appropriate option to fill in blank no. 4.

- Ans
- 1. teaching
 - 2. will teach
 - 3. teaches
 - 4. taught

Question ID : 264330168289

Option 1 ID : 264330660019

Option 2 ID : 264330660020

Option 3 ID : 264330660022

Option 4 ID : 264330660021

Status : Answered

Chosen Option : 4

Comprehension:

In the following passage, some words have been deleted. Fill in the blanks with the help of the alternatives given. Select the most appropriate option for each number.

(1)_____ need for school education reform is impossible to deny on countless fronts in India, from the rule of rote that's suboptimal for (2)_____, to pedagogies that instil fear of math (3)_____ students, especially girls. But while ideating reforms, education policymakers should remember what past experiments (4)_____ them. Remember CCE, continuous and comprehensive evaluation, which was ushered in with hosannas in 2009 but unceremoniously kicked out in 2017. All the turmoil and toil it (5)_____ amounted to zilch in the end. Good idea, poor execution, its epitaph reads.

SubQuestion No : 80

Q.80 Select the most appropriate option to fill in blank no. 5.

- Ans 1. are generate
 2. generated
 3. generating
 4. is generate

Question ID : 264330168290

Option 1 ID : 264330660025

Option 2 ID : 264330660023

Option 3 ID : 264330660024

Option 4 ID : 264330660026

Status : Answered

Chosen Option : 4

Comprehension:

In the following passage some words have been deleted. Fill in the blanks with the help of the alternatives given. Select the most appropriate option for each number.

Let others know ___1___ you are trying to routinely hold crucial conversations. ___2___ what you are doing and why. Here it is worth to mention that over half a century ago, Dr. Kurt Lewin, the father of social psychology, ___3___ that when subjects made a public ___4___ to do something, they were more likely to stay the course than if they ___5___ their wishes to themselves. Tell people what your goals are.

SubQuestion No : 81

Q.81 Select the most appropriate option to fill in blank 1.

- Ans 1. that
 2. what
 3. which
 4. who

Question ID : 264330170235

Option 1 ID : 264330667599

Option 2 ID : 264330667600

Option 3 ID : 264330667601

Option 4 ID : 264330667602

Status : Answered

Chosen Option : 2

Comprehension:

In the following passage some words have been deleted. Fill in the blanks with the help of the alternatives given. Select the most appropriate option for each number.

Let others know ___1___ you are trying to routinely hold crucial conversations. ___2___ what you are doing and why. Here it is worth to mention that over half a century ago, Dr. Kurt Lewin, the father of social psychology, ___3___ that when subjects made a public ___4___ to do something, they were more likely to stay the course than if they ___5___ their wishes to themselves. Tell people what your goals are.

SubQuestion No : 82**Q.82** Select the most appropriate option to fill in blank 2.

- Ans
- 1. Conceal
 - 2. Dramatize
 - 3. Explain
 - 4. Dream

Question ID : 264330170236

Option 1 ID : 264330667603

Option 2 ID : 264330667604

Option 3 ID : 264330667605

Option 4 ID : 264330667606

Status : Answered

Chosen Option : 4

Comprehension:

In the following passage some words have been deleted. Fill in the blanks with the help of the alternatives given. Select the most appropriate option for each number.

Let others know ___1___ you are trying to routinely hold crucial conversations. ___2___ what you are doing and why. Here it is worth to mention that over half a century ago, Dr. Kurt Lewin, the father of social psychology, ___3___ that when subjects made a public ___4___ to do something, they were more likely to stay the course than if they ___5___ their wishes to themselves. Tell people what your goals are.

SubQuestion No : 83**Q.83** Select the most appropriate option to fill in blank 3.

- Ans
- 1. exclaimed
 - 2. learned
 - 3. spoke
 - 4. knew

Question ID : 264330170237

Option 1 ID : 264330667610

Option 2 ID : 264330667608

Option 3 ID : 264330667609

Option 4 ID : 264330667607

Status : Answered

Chosen Option : 3

Comprehension:

In the following passage some words have been deleted. Fill in the blanks with the help of the alternatives given. Select the most appropriate option for each number.

Let others know ___1___ you are trying to routinely hold crucial conversations. ___2___ what you are doing and why. Here it is worth to mention that over half a century ago, Dr. Kurt Lewin, the father of social psychology, ___3___ that when subjects made a public ___4___ to do something, they were more likely to stay the course than if they ___5___ their wishes to themselves. Tell people what your goals are.

SubQuestion No : 84**Q.84** Select the most appropriate option to fill in blank 4.

- Ans
- 1. scene
 - 2. apology
 - 3. commitment
 - 4. display

Question ID : 264330170238

Option 1 ID : 264330667613

Option 2 ID : 264330667611

Option 3 ID : 264330667614

Option 4 ID : 264330667612

Status : Answered

Chosen Option : 3

Comprehension:

In the following passage some words have been deleted. Fill in the blanks with the help of the alternatives given. Select the most appropriate option for each number.

Let others know ___1___ you are trying to routinely hold crucial conversations. ___2___ what you are doing and why. Here it is worth to mention that over half a century ago, Dr. Kurt Lewin, the father of social psychology, ___3___ that when subjects made a public ___4___ to do something, they were more likely to stay the course than if they ___5___ their wishes to themselves. Tell people what your goals are.

SubQuestion No : 85**Q.85** Select the most appropriate option to fill in blank 5.

- Ans
- 1. kept
 - 2. flanked
 - 3. continue
 - 4. conceal

Question ID : 264330170239

Option 1 ID : 264330667616

Option 2 ID : 264330667618

Option 3 ID : 264330667615

Option 4 ID : 264330667617

Status : Answered

Chosen Option : 3

Comprehension:

Read the given passage carefully and answer the questions that follow.

When I first moved to the city, I was taken aback by the pace of life. Everything was always moving, always in a rush. Cars honked their horns, people pushed and shoved their way through the crowds, and the noise was constant. At first, I found it exhilarating. I felt like I was part of something bigger than myself. But as the weeks turned into months, I began to feel overwhelmed.

I noticed that I was becoming increasingly anxious. I was having trouble sleeping, and my thoughts were constantly racing. I knew that I needed to do something to slow down and find some peace. That's when I discovered meditation.

At first, I was sceptical. I had always thought of meditation as something only hippies and yogis did. But I was desperate, so I gave it a try. I found a quiet place in my apartment, sat down cross-legged, and closed my eyes. At first, my mind was still racing, but I focused on my breath and tried to let go of my thoughts. Slowly, I felt my body relax, and my mind grew calmer.

Over the next few weeks, I began to notice the effects of my meditation practice. I felt less anxious and more centred. I was able to sleep better, and I felt more focused during the day. I started to see the world around me with new eyes. The noise and chaos of the city no longer bothered me as much. I felt more in control of my thoughts and emotions.

As I continued to meditate, I started to make other changes in my life. I started to eat healthier, exercise more, and spend more time outside. I found that these small changes had a big impact on my overall sense of well-being. I realised that the frenzied pace of city life had been taking a toll on me, and that I needed to take better care of myself.

Looking back, I can see how my decision to start meditating had a ripple effect on my life. It was the catalyst for a series of changes that have made me a happier and healthier person. I'm still amazed at how something as simple as sitting down and closing my eyes for a few minutes each day could have such a profound impact.

In conclusion, the fast-paced life of the city had a negative effect on my mental and physical health. But by taking the time to meditate and make other positive changes, I was able to improve my overall well-being. I encourage anyone feeling overwhelmed or stressed to give meditation a try. You never know how it might change your life.

SubQuestion No : 86

Q.86 How does the author describe his experiences with meditation?

- Ans
- 1. In a detached and analytical manner
 - 2. In a personal and reflective manner
 - 3. In a formal and technical manner
 - 4. In a dismissive and sarcastic manner

Question ID : 264330166376

Option 1 ID : 264330652555

Option 2 ID : 264330652557

Option 3 ID : 264330652556

Option 4 ID : 264330652558

Status : Answered

Chosen Option : 2

Comprehension:

Read the given passage carefully and answer the questions that follow.

When I first moved to the city, I was taken aback by the pace of life. Everything was always moving, always in a rush. Cars honked their horns, people pushed and shoved their way through the crowds, and the noise was constant. At first, I found it exhilarating. I felt like I was part of something bigger than myself. But as the weeks turned into months, I began to feel overwhelmed.

I noticed that I was becoming increasingly anxious. I was having trouble sleeping, and my thoughts were constantly racing. I knew that I needed to do something to slow down and find some peace. That's when I discovered meditation.

At first, I was sceptical. I had always thought of meditation as something only hippies and yogis did. But I was desperate, so I gave it a try. I found a quiet place in my apartment, sat down cross-legged, and closed my eyes. At first, my mind was still racing, but I focused on my breath and tried to let go of my thoughts. Slowly, I felt my body relax, and my mind grew calmer.

Over the next few weeks, I began to notice the effects of my meditation practice. I felt less anxious and more centred. I was able to sleep better, and I felt more focused during the day. I started to see the world around me with new eyes. The noise and chaos of the city no longer bothered me as much. I felt more in control of my thoughts and emotions.

As I continued to meditate, I started to make other changes in my life. I started to eat healthier, exercise more, and spend more time outside. I found that these small changes had a big impact on my overall sense of well-being. I realised that the frenzied pace of city life had been taking a toll on me, and that I needed to take better care of myself.

Looking back, I can see how my decision to start meditating had a ripple effect on my life. It was the catalyst for a series of changes that have made me a happier and healthier person. I'm still amazed at how something as simple as sitting down and closing my eyes for a few minutes each day could have such a profound impact.

In conclusion, the fast-paced life of the city had a negative effect on my mental and physical health. But by taking the time to meditate and make other positive changes, I was able to improve my overall well-being. I encourage anyone feeling overwhelmed or stressed to give meditation a try. You never know how it might change your life.

SubQuestion No : 87

Q.87 Which of the following is the most appropriate title for the passage?

- Ans 1. The Benefits of Meditation for a Healthier Life
 2. The Best Ways to Improve Your Habits
 3. The Benefits of a High-Protein Diet for Muscle Building
 4. A Note to My Future Self

Question ID : 264330166372

Option 1 ID : 264330652540

Option 2 ID : 264330652539

Option 3 ID : 264330652541

Option 4 ID : 264330652542

Status : Answered

Chosen Option : 2

Comprehension:

Read the given passage carefully and answer the questions that follow.

When I first moved to the city, I was taken aback by the pace of life. Everything was always moving, always in a rush. Cars honked their horns, people pushed and shoved their way through the crowds, and the noise was constant. At first, I found it exhilarating. I felt like I was part of something bigger than myself. But as the weeks turned into months, I began to feel overwhelmed.

I noticed that I was becoming increasingly anxious. I was having trouble sleeping, and my thoughts were constantly racing. I knew that I needed to do something to slow down and find some peace. That's when I discovered meditation.

At first, I was sceptical. I had always thought of meditation as something only hippies and yogis did. But I was desperate, so I gave it a try. I found a quiet place in my apartment, sat down cross-legged, and closed my eyes. At first, my mind was still racing, but I focused on my breath and tried to let go of my thoughts. Slowly, I felt my body relax, and my mind grew calmer.

Over the next few weeks, I began to notice the effects of my meditation practice. I felt less anxious and more centred. I was able to sleep better, and I felt more focused during the day. I started to see the world around me with new eyes. The noise and chaos of the city no longer bothered me as much. I felt more in control of my thoughts and emotions.

As I continued to meditate, I started to make other changes in my life. I started to eat healthier, exercise more, and spend more time outside. I found that these small changes had a big impact on my overall sense of well-being. I realised that the frenzied pace of city life had been taking a toll on me, and that I needed to take better care of myself.

Looking back, I can see how my decision to start meditating had a ripple effect on my life. It was the catalyst for a series of changes that have made me a happier and healthier person. I'm still amazed at how something as simple as sitting down and closing my eyes for a few minutes each day could have such a profound impact.

In conclusion, the fast-paced life of the city had a negative effect on my mental and physical health. But by taking the time to meditate and make other positive changes, I was able to improve my overall well-being. I encourage anyone feeling overwhelmed or stressed to give meditation a try. You never know how it might change your life.

SubQuestion No : 88

Q.88 How does the author organise the passage?

- Ans
- 1. By describing the history of meditation
 - 2. By listing different types of meditation
 - 3. By providing scientific evidence for the benefits of meditation
 - 4. By presenting personal experiences with meditation

Question ID : 264330166375

Option 1 ID : 264330652552

Option 2 ID : 264330652551

Option 3 ID : 264330652554

Option 4 ID : 264330652553

Status : Answered

Chosen Option : 4

Comprehension:

Read the given passage carefully and answer the questions that follow.

When I first moved to the city, I was taken aback by the pace of life. Everything was always moving, always in a rush. Cars honked their horns, people pushed and shoved their way through the crowds, and the noise was constant. At first, I found it exhilarating. I felt like I was part of something bigger than myself. But as the weeks turned into months, I began to feel overwhelmed.

I noticed that I was becoming increasingly anxious. I was having trouble sleeping, and my thoughts were constantly racing. I knew that I needed to do something to slow down and find some peace. That's when I discovered meditation.

At first, I was sceptical. I had always thought of meditation as something only hippies and yogis did. But I was desperate, so I gave it a try. I found a quiet place in my apartment, sat down cross-legged, and closed my eyes. At first, my mind was still racing, but I focused on my breath and tried to let go of my thoughts. Slowly, I felt my body relax, and my mind grew calmer.

Over the next few weeks, I began to notice the effects of my meditation practice. I felt less anxious and more centred. I was able to sleep better, and I felt more focused during the day. I started to see the world around me with new eyes. The noise and chaos of the city no longer bothered me as much. I felt more in control of my thoughts and emotions.

As I continued to meditate, I started to make other changes in my life. I started to eat healthier, exercise more, and spend more time outside. I found that these small changes had a big impact on my overall sense of well-being. I realised that the frenzied pace of city life had been taking a toll on me, and that I needed to take better care of myself.

Looking back, I can see how my decision to start meditating had a ripple effect on my life. It was the catalyst for a series of changes that have made me a happier and healthier person. I'm still amazed at how something as simple as sitting down and closing my eyes for a few minutes each day could have such a profound impact.

In conclusion, the fast-paced life of the city had a negative effect on my mental and physical health. But by taking the time to meditate and make other positive changes, I was able to improve my overall well-being. I encourage anyone feeling overwhelmed or stressed to give meditation a try. You never know how it might change your life.

SubQuestion No : 89

Q.89 How did the author feel after meditating for a few weeks?

- Ans
- 1. More anxious and overwhelmed
 - 2. Less centred and focused
 - 3. More energised and restless
 - 4. More relaxed and calmer

Question ID : 264330166373

Option 1 ID : 264330652543

Option 2 ID : 264330652544

Option 3 ID : 264330652546

Option 4 ID : 264330652545

Status : Answered

Chosen Option : 4

Comprehension:

Read the given passage carefully and answer the questions that follow.

When I first moved to the city, I was taken aback by the pace of life. Everything was always moving, always in a rush. Cars honked their horns, people pushed and shoved their way through the crowds, and the noise was constant. At first, I found it exhilarating. I felt like I was part of something bigger than myself. But as the weeks turned into months, I began to feel overwhelmed.

I noticed that I was becoming increasingly anxious. I was having trouble sleeping, and my thoughts were constantly racing. I knew that I needed to do something to slow down and find some peace. That's when I discovered meditation.

At first, I was sceptical. I had always thought of meditation as something only hippies and yogis did. But I was desperate, so I gave it a try. I found a quiet place in my apartment, sat down cross-legged, and closed my eyes. At first, my mind was still racing, but I focused on my breath and tried to let go of my thoughts. Slowly, I felt my body relax, and my mind grew calmer.

Over the next few weeks, I began to notice the effects of my meditation practice. I felt less anxious and more centred. I was able to sleep better, and I felt more focused during the day. I started to see the world around me with new eyes. The noise and chaos of the city no longer bothered me as much. I felt more in control of my thoughts and emotions.

As I continued to meditate, I started to make other changes in my life. I started to eat healthier, exercise more, and spend more time outside. I found that these small changes had a big impact on my overall sense of well-being. I realised that the frenzied pace of city life had been taking a toll on me, and that I needed to take better care of myself.

Looking back, I can see how my decision to start meditating had a ripple effect on my life. It was the catalyst for a series of changes that have made me a happier and healthier person. I'm still amazed at how something as simple as sitting down and closing my eyes for a few minutes each day could have such a profound impact.

In conclusion, the fast-paced life of the city had a negative effect on my mental and physical health. But by taking the time to meditate and make other positive changes, I was able to improve my overall well-being. I encourage anyone feeling overwhelmed or stressed to give meditation a try. You never know how it might change your life.

SubQuestion No : 90

Q.90 What is the subject of this passage?

- Ans
- 1. The benefits of meditation for a healthier life.
 - 2. The benefits of socialising for emotional well-being.
 - 3. The benefits of eating healthy for physical health.
 - 4. The benefits of exercise for mental health.

Question ID : 264330166374

Option 1 ID : 264330652549

Option 2 ID : 264330652548

Option 3 ID : 264330652550

Option 4 ID : 264330652547

Status : Answered

Chosen Option : 1

Comprehension:

Read the given passage and answer the question that follows.

There are three main groups of oils: animal, vegetable, and mineral. Great quantities of animal oil come from whales, creatures of the sea, which are the largest of the remaining animals in the world. To protect the whales from the cold of the Arctic seas, nature has provided them with a thick covering of fat, called blubber. When the whale is killed, the blubber is stripped off and boiled down. It produces a great quantity of oil which can be made into food for human consumption. A few other creatures yield oil, but none so much as the whale. The livers of cod and halibut, two kinds of fish, yield nourishing oil. Both cod liver oil and halibut oil are given to sick children who need certain vitamins. No household can get by without oil, for it is used in cooking. Perfumes and soaps may be made from the oils of certain flowers.

SubQuestion No : 91

Q.91 Identify the central theme of the passage.

- Ans
- 1. Kinds of fish
 - 2. Creatures of the sea
 - 3. Protection of whales
 - 4. Animal oil

Question ID : 264330165249

Option 1 ID : 264330648092

Option 2 ID : 264330648094

Option 3 ID : 264330648093

Option 4 ID : 264330648091

Status : Answered

Chosen Option : 4

Comprehension:

Read the given passage and answer the question that follows.

There are three main groups of oils: animal, vegetable, and mineral. Great quantities of animal oil come from whales, creatures of the sea, which are the largest of the remaining animals in the world. To protect the whales from the cold of the Arctic seas, nature has provided them with a thick covering of fat, called blubber. When the whale is killed, the blubber is stripped off and boiled down. It produces a great quantity of oil which can be made into food for human consumption. A few other creatures yield oil, but none so much as the whale. The livers of cod and halibut, two kinds of fish, yield nourishing oil. Both cod liver oil and halibut oil are given to sick children who need certain vitamins. No household can get by without oil, for it is used in cooking. Perfumes and soaps may be made from the oils of certain flowers.

SubQuestion No : 92

Q.92 Which oil is recommended for sick children, and why is it recommended to them?

- Ans
- 1. Whale oil, as it contains vitamins
 - 2. Cod liver oil and halibut oil, as it contains vitamins
 - 3. Vegetable oil, as it is good for health
 - 4. Whale oil, as it is from blubber

Question ID : 264330165251

Option 1 ID : 264330648100

Option 2 ID : 264330648101

Option 3 ID : 264330648099

Option 4 ID : 264330648102

Status : Answered

Chosen Option : 4

Comprehension:

Read the given passage and answer the question that follows.

There are three main groups of oils: animal, vegetable, and mineral. Great quantities of animal oil come from whales, creatures of the sea, which are the largest of the remaining animals in the world. To protect the whales from the cold of the Arctic seas, nature has provided them with a thick covering of fat, called blubber. When the whale is killed, the blubber is stripped off and boiled down. It produces a great quantity of oil which can be made into food for human consumption. A few other creatures yield oil, but none so much as the whale. The livers of cod and halibut, two kinds of fish, yield nourishing oil. Both cod liver oil and halibut oil are given to sick children who need certain vitamins. No household can get by without oil, for it is used in cooking. Perfumes and soaps may be made from the oils of certain flowers.

SubQuestion No : 93

Q.93 Which of the following does NOT involve the use of oils, according to the passage?

- Ans 1. Making of shoes
 2. Making soaps
 3. Making perfumes
 4. Household cooking

Question ID : 264330165253

Option 1 ID : 264330648108

Option 2 ID : 264330648109

Option 3 ID : 264330648110

Option 4 ID : 264330648107

Status : Answered

Chosen Option : 1

Comprehension:

Read the given passage and answer the question that follows.

There are three main groups of oils: animal, vegetable, and mineral. Great quantities of animal oil come from whales, creatures of the sea, which are the largest of the remaining animals in the world. To protect the whales from the cold of the Arctic seas, nature has provided them with a thick covering of fat, called blubber. When the whale is killed, the blubber is stripped off and boiled down. It produces a great quantity of oil which can be made into food for human consumption. A few other creatures yield oil, but none so much as the whale. The livers of cod and halibut, two kinds of fish, yield nourishing oil. Both cod liver oil and halibut oil are given to sick children who need certain vitamins. No household can get by without oil, for it is used in cooking. Perfumes and soaps may be made from the oils of certain flowers.

SubQuestion No : 94

Q.94 How are the whales protected naturally?

- Ans 1. By their huge size
 2. By having the habitat of the Arctic sea
 3. By the presence of a thick fat covering
 4. By their oil producing quality

Question ID : 264330165250

Option 1 ID : 264330648096

Option 2 ID : 264330648098

Option 3 ID : 264330648097

Option 4 ID : 264330648095

Status : Answered

Chosen Option : 3

Comprehension:

Read the given passage and answer the question that follows.

There are three main groups of oils: animal, vegetable, and mineral. Great quantities of animal oil come from whales, creatures of the sea, which are the largest of the remaining animals in the world. To protect the whales from the cold of the Arctic seas, nature has provided them with a thick covering of fat, called blubber. When the whale is killed, the blubber is stripped off and boiled down. It produces a great quantity of oil which can be made into food for human consumption. A few other creatures yield oil, but none so much as the whale. The livers of cod and halibut, two kinds of fish, yield nourishing oil. Both cod liver oil and halibut oil are given to sick children who need certain vitamins. No household can get by without oil, for it is used in cooking. Perfumes and soaps may be made from the oils of certain flowers.

SubQuestion No : 95

Q.95 Select the most appropriate **ANTONYM** of the given word in the context of the passage.
Consumption

- Ans** ✓ 1. Creation
 ✗ 2. Depletion
 ✗ 3. Utilisation
 ✗ 4. Elation

Question ID : **264330165252**

Option 1 ID : **264330648105**

Option 2 ID : **264330648103**

Option 3 ID : **264330648104**

Option 4 ID : **264330648106**

Status : **Not Answered**

Chosen Option : --



Prepare 50% Faster

Comprehension:

Read the given passage and answer the questions that follow.

Remote work, the ability to work from home or other locations outside of the traditional office setting, has become increasingly popular in recent years. With the development of new technologies, remote work is now possible for many jobs that previously required employees to be physically present in the office. This shift towards remote work has been driven by a number of factors, including the desire for increased flexibility, reduced overhead costs and improved work-life balance.

One of the primary benefits of remote work is the flexibility it provides. Employees are able to work from wherever they choose, whether that be from the comfort of their own homes, a local coffee shop or even while travelling. This flexibility can allow employees to better balance work and personal responsibilities and can result in higher job satisfaction and retention rates. Employers also benefit from increased flexibility, as remote work can lead to reduced overhead costs, such as rent and utilities for office space.

In addition to flexibility, remote work has also been linked to increased productivity. Many studies have shown that employees who work from home are often more productive than those who work in a traditional office setting. This is due in part to reduced distractions and interruptions, as well as the ability to work during one's most productive hours, rather than adhering to a traditional 9-to-5 schedule. Furthermore, remote work can lead to a more diverse and inclusive workforce, as individuals with disabilities or caregiving responsibilities can more easily participate in the workforce.

Despite the benefits, there are also some drawbacks to consider when it comes to remote work. One of the primary concerns is the lack of social interaction and collaboration. When employees are working remotely, they may miss out on the benefits of in-person collaboration, such as brainstorming sessions and the ability to bounce ideas off of colleagues. Additionally, remote work can lead to feelings of isolation and loneliness, which can have a negative impact on mental health and job satisfaction.

Another potential drawback of remote work is the potential for blurred boundaries between work and personal life. When employees work from home, it can be difficult to separate work time from personal time, leading to longer work hours and decreased work-life balance.

Additionally, without the structure of a traditional office environment, it can be easy for employees to become distracted or procrastinate, leading to decreased productivity.

Overall, while remote work offers many benefits, it is important for both employees and employers to consider the potential drawbacks and take steps to mitigate them. This may include finding ways to maintain social interaction and collaboration, setting clear boundaries between work and personal time and establishing a structured routine to ensure productivity and work-life balance. As remote work continues to become more prevalent, it is important to balance its benefits with its potential challenges and find ways to create a productive and healthy remote work environment.

SubQuestion No : 96

Q.96 Which of the following statements best represents a real-world example of 'blurred boundaries' in remote work as described in the passage?

- Ans** 1. A worker who is easily distracted by personal responsibilities and household chores during their remote work hours, leading to decreased productivity and missed deadlines.
2. An employee who works from home occasionally responds to work emails after their normal working hours, leading to burnout and decreased productivity.
3. An employee who sets up a dedicated workspace in their home and follows a structured work schedule to maintain a healthy work-life balance.
4. A worker who is required to come into the office every day but also frequently works from home due to personal reasons, resulting in reduced social interaction with co-workers.

Question ID : 264330167977

Option 1 ID : 264330658802

Option 2 ID : 264330658799

Option 3 ID : 264330658801

Option 4 ID : 264330658800

Status : Answered

Chosen Option : 2

Comprehension:

Read the given passage and answer the questions that follow.

Remote work, the ability to work from home or other locations outside of the traditional office setting, has become increasingly popular in recent years. With the development of new technologies, remote work is now possible for many jobs that previously required employees to be physically present in the office. This shift towards remote work has been driven by a number of factors, including the desire for increased flexibility, reduced overhead costs and improved work-life balance.

One of the primary benefits of remote work is the flexibility it provides. Employees are able to work from wherever they choose, whether that be from the comfort of their own homes, a local coffee shop or even while travelling. This flexibility can allow employees to better balance work and personal responsibilities and can result in higher job satisfaction and retention rates. Employers also benefit from increased flexibility, as remote work can lead to reduced overhead costs, such as rent and utilities for office space.

In addition to flexibility, remote work has also been linked to increased productivity. Many studies have shown that employees who work from home are often more productive than those who work in a traditional office setting. This is due in part to reduced distractions and interruptions, as well as the ability to work during one's most productive hours, rather than adhering to a traditional 9-to-5 schedule. Furthermore, remote work can lead to a more diverse and inclusive workforce, as individuals with disabilities or caregiving responsibilities can more easily participate in the workforce.

Despite the benefits, there are also some drawbacks to consider when it comes to remote work. One of the primary concerns is the lack of social interaction and collaboration. When employees are working remotely, they may miss out on the benefits of in-person collaboration, such as brainstorming sessions and the ability to bounce ideas off of colleagues. Additionally, remote work can lead to feelings of isolation and loneliness, which can have a negative impact on mental health and job satisfaction.

Another potential drawback of remote work is the potential for blurred boundaries between work and personal life. When employees work from home, it can be difficult to separate work time from personal time, leading to longer work hours and decreased work-life balance.

Additionally, without the structure of a traditional office environment, it can be easy for employees to become distracted or procrastinate, leading to decreased productivity.

Overall, while remote work offers many benefits, it is important for both employees and employers to consider the potential drawbacks and take steps to mitigate them. This may include finding ways to maintain social interaction and collaboration, setting clear boundaries between work and personal time and establishing a structured routine to ensure productivity and work-life balance. As remote work continues to become more prevalent, it is important to balance its benefits with its potential challenges and find ways to create a productive and healthy remote work environment.

SubQuestion No : 97

Q.97 Which of the following is a reason why remote workers are often more productive than those who work in a traditional office setting, according to the passage?

- Ans
- 1. Remote workers have access to better technology and equipment.
 - 2. Remote workers have more opportunities for in-person collaboration.
 - 3. Remote workers have fewer distractions and interruptions.
 - 4. Remote workers are given more autonomy and control over their work.

Question ID : 264330167976

Option 1 ID : 264330658795

Option 2 ID : 264330658798

Option 3 ID : 264330658797

Option 4 ID : 264330658796

Status : Not Answered

Chosen Option : --

Comprehension:

Read the given passage and answer the questions that follow.

Remote work, the ability to work from home or other locations outside of the traditional office setting, has become increasingly popular in recent years. With the development of new technologies, remote work is now possible for many jobs that previously required employees to be physically present in the office. This shift towards remote work has been driven by a number of factors, including the desire for increased flexibility, reduced overhead costs and improved work-life balance.

One of the primary benefits of remote work is the flexibility it provides. Employees are able to work from wherever they choose, whether that be from the comfort of their own homes, a local coffee shop or even while travelling. This flexibility can allow employees to better balance work and personal responsibilities and can result in higher job satisfaction and retention rates. Employers also benefit from increased flexibility, as remote work can lead to reduced overhead costs, such as rent and utilities for office space.

In addition to flexibility, remote work has also been linked to increased productivity. Many studies have shown that employees who work from home are often more productive than those who work in a traditional office setting. This is due in part to reduced distractions and interruptions, as well as the ability to work during one's most productive hours, rather than adhering to a traditional 9-to-5 schedule. Furthermore, remote work can lead to a more diverse and inclusive workforce, as individuals with disabilities or caregiving responsibilities can more easily participate in the workforce.

Despite the benefits, there are also some drawbacks to consider when it comes to remote work. One of the primary concerns is the lack of social interaction and collaboration. When employees are working remotely, they may miss out on the benefits of in-person collaboration, such as brainstorming sessions and the ability to bounce ideas off of colleagues. Additionally, remote work can lead to feelings of isolation and loneliness, which can have a negative impact on mental health and job satisfaction.

Another potential drawback of remote work is the potential for blurred boundaries between work and personal life. When employees work from home, it can be difficult to separate work time from personal time, leading to longer work hours and decreased work-life balance.

Additionally, without the structure of a traditional office environment, it can be easy for employees to become distracted or procrastinate, leading to decreased productivity.

Overall, while remote work offers many benefits, it is important for both employees and employers to consider the potential drawbacks and take steps to mitigate them. This may include finding ways to maintain social interaction and collaboration, setting clear boundaries between work and personal time and establishing a structured routine to ensure productivity and work-life balance. As remote work continues to become more prevalent, it is important to balance its benefits with its potential challenges and find ways to create a productive and healthy remote work environment.

SubQuestion No : 98

Q.98 How does remote work contribute to a more diverse and inclusive workforce?

- Ans
- 1. It creates opportunities for in-person collaboration.
 - 2. It leads to increased productivity.
 - 3. It allows individuals with disabilities to participate in the workforce.
 - 4. It promotes work-life balance.

Question ID : 264330167975

Option 1 ID : 264330658792

Option 2 ID : 264330658793

Option 3 ID : 264330658791

Option 4 ID : 264330658794

Status : Not Answered

Chosen Option : --

Comprehension:

Read the given passage and answer the questions that follow.

Remote work, the ability to work from home or other locations outside of the traditional office setting, has become increasingly popular in recent years. With the development of new technologies, remote work is now possible for many jobs that previously required employees to be physically present in the office. This shift towards remote work has been driven by a number of factors, including the desire for increased flexibility, reduced overhead costs and improved work-life balance.

One of the primary benefits of remote work is the flexibility it provides. Employees are able to work from wherever they choose, whether that be from the comfort of their own homes, a local coffee shop or even while travelling. This flexibility can allow employees to better balance work and personal responsibilities and can result in higher job satisfaction and retention rates. Employers also benefit from increased flexibility, as remote work can lead to reduced overhead costs, such as rent and utilities for office space.

In addition to flexibility, remote work has also been linked to increased productivity. Many studies have shown that employees who work from home are often more productive than those who work in a traditional office setting. This is due in part to reduced distractions and interruptions, as well as the ability to work during one's most productive hours, rather than adhering to a traditional 9-to-5 schedule. Furthermore, remote work can lead to a more diverse and inclusive workforce, as individuals with disabilities or caregiving responsibilities can more easily participate in the workforce.

Despite the benefits, there are also some drawbacks to consider when it comes to remote work. One of the primary concerns is the lack of social interaction and collaboration. When employees are working remotely, they may miss out on the benefits of in-person collaboration, such as brainstorming sessions and the ability to bounce ideas off of colleagues. Additionally, remote work can lead to feelings of isolation and loneliness, which can have a negative impact on mental health and job satisfaction.

Another potential drawback of remote work is the potential for blurred boundaries between work and personal life. When employees work from home, it can be difficult to separate work time from personal time, leading to longer work hours and decreased work-life balance.

Additionally, without the structure of a traditional office environment, it can be easy for employees to become distracted or procrastinate, leading to decreased productivity.

Overall, while remote work offers many benefits, it is important for both employees and employers to consider the potential drawbacks and take steps to mitigate them. This may include finding ways to maintain social interaction and collaboration, setting clear boundaries between work and personal time and establishing a structured routine to ensure productivity and work-life balance. As remote work continues to become more prevalent, it is important to balance its benefits with its potential challenges and find ways to create a productive and healthy remote work environment.

SubQuestion No : 99

Q.99 What is the central theme of the passage?

- Ans 1. The history and evolution of remote work
2. Identifying the benefits and drawbacks of remote work for both employees and employers.
3. The impact of remote work on mental health and job satisfaction
4. The potential challenges of creating a productive remote work environment

Question ID : 264330167974

Option 1 ID : 264330658788

Option 2 ID : 264330658787

Option 3 ID : 264330658790

Option 4 ID : 264330658789

Status : Answered

Chosen Option : 3

Comprehension:

Read the given passage and answer the questions that follow.

Remote work, the ability to work from home or other locations outside of the traditional office setting, has become increasingly popular in recent years. With the development of new technologies, remote work is now possible for many jobs that previously required employees to be physically present in the office. This shift towards remote work has been driven by a number of factors, including the desire for increased flexibility, reduced overhead costs and improved work-life balance.

One of the primary benefits of remote work is the flexibility it provides. Employees are able to work from wherever they choose, whether that be from the comfort of their own homes, a local coffee shop or even while travelling. This flexibility can allow employees to better balance work and personal responsibilities and can result in higher job satisfaction and retention rates. Employers also benefit from increased flexibility, as remote work can lead to reduced overhead costs, such as rent and utilities for office space.

In addition to flexibility, remote work has also been linked to increased productivity. Many studies have shown that employees who work from home are often more productive than those who work in a traditional office setting. This is due in part to reduced distractions and interruptions, as well as the ability to work during one's most productive hours, rather than adhering to a traditional 9-to-5 schedule. Furthermore, remote work can lead to a more diverse and inclusive workforce, as individuals with disabilities or caregiving responsibilities can more easily participate in the workforce.

Despite the benefits, there are also some drawbacks to consider when it comes to remote work. One of the primary concerns is the lack of social interaction and collaboration. When employees are working remotely, they may miss out on the benefits of in-person collaboration, such as brainstorming sessions and the ability to bounce ideas off of colleagues. Additionally, remote work can lead to feelings of isolation and loneliness, which can have a negative impact on mental health and job satisfaction.

Another potential drawback of remote work is the potential for blurred boundaries between work and personal life. When employees work from home, it can be difficult to separate work time from personal time, leading to longer work hours and decreased work-life balance.

Additionally, without the structure of a traditional office environment, it can be easy for employees to become distracted or procrastinate, leading to decreased productivity.

Overall, while remote work offers many benefits, it is important for both employees and employers to consider the potential drawbacks and take steps to mitigate them. This may include finding ways to maintain social interaction and collaboration, setting clear boundaries between work and personal time and establishing a structured routine to ensure productivity and work-life balance. As remote work continues to become more prevalent, it is important to balance its benefits with its potential challenges and find ways to create a productive and healthy remote work environment.

SubQuestion No : 100

Q.100 What has driven the shift towards remote work?

- Ans
- 1. Desire for reduced flexibility
 - 2. Reduced work-life balance
 - 3. Increased overhead costs
 - 4. New technologies

Question ID : 264330167973

Option 1 ID : 264330658784

Option 2 ID : 264330658786

Option 3 ID : 264330658783

Option 4 ID : 264330658785

Status : Answered

Chosen Option : 2

Stenographer Grade C and D Examination 2023

Roll Number	
Candidate Name	
Venue Name	Maharishi Arvind Institute of Engineering and Technology
Exam Date	13/10/2023
Exam Time	12:30 PM - 2:30 PM
Subject	Stenographer Grade C and D Examination 2023

Section : General Intelligence and Reasoning

Q.1 नीचे तीन कथन और उसके बाद I, II और III संख्यांकित वाले तीन निष्कर्ष दिये गए हैं। यह मानते हुए कि कथनों में दी गई जानकारी सत्य है, भले ही ये कथन सामान्य रूप से ज्ञात तथ्यों से भिन्न प्रतीत होते हों, यह निर्णय कीजिए कि कौन सा/से निष्कर्ष इन कथनों का तार्किक रूप से अनुसरण करता है/करते हैं।

कथन:

सभी स्विच पंखे हैं।

कोई हीटर पंखा नहीं है।

कुछ तार हीटर हैं।

निष्कर्ष:

I. कुछ तार पंखे हैं।

II. कोई स्विच हीटर नहीं है।

III. कोई तार स्विच नहीं है।

- Ans
- 1. निष्कर्ष I और II दोनों अनुसरण करते हैं।
 - 2. केवल निष्कर्ष I अनुसरण करता है।
 - 3. निष्कर्ष I और III दोनों अनुसरण करते हैं।
 - 4. केवल निष्कर्ष II अनुसरण करता है।

Question ID : 264330144911

Option 1 ID : 264330567899

Option 2 ID : 264330567902

Option 3 ID : 264330567900

Option 4 ID : 264330567901

Status : Answered

Chosen Option : 4

Q.2 कौन-सा अक्षर-समूह दी गई श्रृंखला की पूर्ति के लिए प्रश्नचिह्न (?) को प्रतिस्थापित करेगा?
BLRW, DMUX, FNXY, ?, JPDA

- Ans
- 1. HAYO
 - 2. HOAX
 - 3. HOAZ
 - 4. HAZO

Question ID : 26433076664

Option 1 ID : 264330300721

Option 2 ID : 264330300723

Option 3 ID : 264330300722

Option 4 ID : 264330300720

Status : Answered

Chosen Option : 3

Q.3 निम्नलिखित में से कौन-सी संख्या, दी गई श्रृंखला में प्रश्नचिह्न (?) को प्रतिस्थापित करेगी?
52, 69, 86, 103, ?, 137

- Ans
- 1. 123
 - 2. 109
 - 3. 112
 - 4. 120

Question ID : 264330102153

Option 1 ID : 264330401080

Option 2 ID : 264330401078

Option 3 ID : 264330401077

Option 4 ID : 264330401079

Status : Answered

Chosen Option : 4

Q.4 तीन कथनों के बाद I, II, III और IV से संख्यांकित चार निष्कर्ष दिए गए हैं। कथनों को सत्य मानते हुए, भले ही वे सामान्य रूप से ज्ञात तथ्यों से भिन्न प्रतीत होते हों, तय करें कि दिए गए निष्कर्षों में से कौन सा/से निष्कर्ष कथनों का तार्किक रूप से अनुसरण करता है/करते हैं।

कथन:

सभी लैपटॉप, डेस्कटॉप हैं।

सभी डेस्कटॉप, प्रिंटर हैं।

कुछ प्रिंटर, मॉनीटर हैं।

निष्कर्ष:

I. कुछ लैपटॉप, मॉनीटर हैं।

II. कुछ मॉनीटर, डेस्कटॉप हैं।

III. सभी लैपटॉप, प्रिंटर हैं।

IV. कुछ मॉनीटर, प्रिंटर हैं।

- Ans
- 1. केवल निष्कर्ष I और IV अनुसरण करते हैं
 - 2. केवल निष्कर्ष I और II अनुसरण करते हैं
 - 3. केवल निष्कर्ष II और III अनुसरण करते हैं
 - 4. केवल निष्कर्ष III और IV अनुसरण करते हैं

Question ID : 26433097232

Option 1 ID : 264330381628

Option 2 ID : 264330381625

Option 3 ID : 264330381626

Option 4 ID : 264330381627

Status : Answered

Chosen Option : 4

Q.5 निम्नलिखित चार अक्षर-समूहों में से तीन एक निश्चित तरीके से आपस में संगत हैं, जबकि कोई एक उनसे असंगत है। असंगत अक्षर-समूह का चयन करें।

- Ans
- 1. IRHQ
 - 2. FUET
 - 3. KPJO
 - 4. DWEU

Question ID : 26433068783

Option 1 ID : 264330269645

Option 2 ID : 264330269644

Option 3 ID : 264330269647

Option 4 ID : 264330269646

Status : Answered

Chosen Option : 4

Q.6 उस विकल्प का चयन करें जो पांचवीं संख्या से उसी प्रकार संबंधित है जैसे पहली संख्या दूसरी संख्या से और तीसरी संख्या चौथी संख्या से संबंधित है।
32 : 5 :: 76 : 13 :: 99 : ?

- Ans 1. 18
 2. 13
 3. 21
 4. 11

Question ID : 26433079109
Option 1 ID : 264330310440
Option 2 ID : 264330310442
Option 3 ID : 264330310443
Option 4 ID : 264330310441
Status : Answered
Chosen Option : 1

Q.7 बिंदु A, बिंदु B से 35 m पूर्व में है। बिंदु C, बिंदु B से 28 m दक्षिण में है। बिंदु C, बिंदु D से 15 m पूर्व में है। बिंदु E, बिंदु D से 14 m उत्तर में है। बिंदु F, बिंदु E से 20 m पूर्व में है। बिंदु F के सापेक्ष बिंदु A किस दिशा में है?

- Ans 1. उत्तर
 2. पश्चिम
 3. दक्षिण-पूर्व
 4. उत्तर-पूर्व

Question ID : 264330131627
Option 1 ID : 264330515608
Option 2 ID : 264330515609
Option 3 ID : 264330515607
Option 4 ID : 264330515610
Status : Answered
Chosen Option : 4

Q.8 उस विकल्प का चयन करें जो तीसरे शब्द से उसी प्रकार संबंधित है जिस प्रकार दूसरा शब्द पहले शब्द से संबंधित है।
शब्दों को अर्थपूर्ण अंग्रेजी/हिन्दी शब्दों के रूप में माना जाना चाहिए और इन्हें शब्द में अक्षरों की संख्या/ व्यंजनों की संख्या/स्वरों की संख्या के आधार पर एक-दूसरे से संबद्ध नहीं किया जाना चाहिए।
त्रिभुज : 3 :: षट्भुज : ?

- Ans 1. 5
 2. 4
 3. 6
 4. 8

Question ID : 26433087288
Option 1 ID : 264330342790
Option 2 ID : 264330342789
Option 3 ID : 264330342791
Option 4 ID : 264330342792
Status : Answered
Chosen Option : 3

Q.9 निम्नांकित श्रृंखला में पैटर्न को जारी रखने के लिए प्रश्नचिह्न (?) को किस आकृति द्वारा प्रतिस्थापित किया जाना चाहिए?

M	Q	M	△	
△ C T	T Z △	Q T Z	Z 9 Q	?
	Q	M	△	M

Ans

✗ 1.

M
Q △ Z
9

✓ 2.

M
△ Z 9
Q

✗ 3.

M
Q Z 9
△

✗ 4.

M
9 Q Z
△

Question ID : 264330129592

Option 1 ID : 264330507735

Option 2 ID : 264330507734

Option 3 ID : 264330507736

Option 4 ID : 264330507737

Status : Not Attempted and Marked For Review

Chosen Option : --

Q.10 इस प्रश्न में, एक कथन के बाद दो निष्कर्ष दिए गए हैं। दोनों में से कौन-सा/से निष्कर्ष सत्य है/हैं?

कथन: $G = Y < U \leq F > P > T < V$

निष्कर्ष: I. $F > G$

II. $F > T$

- Ans
- 1. केवल निष्कर्ष I सत्य है।
 - 2. निष्कर्ष I और II दोनों सत्य हैं।
 - 3. केवल निष्कर्ष II सत्य है।
 - 4. न तो निष्कर्ष I और न ही II सत्य है।

Question ID : 26433057322
Option 1 ID : 264330224272
Option 2 ID : 264330224274
Option 3 ID : 264330224273
Option 4 ID : 264330224275
Status : Answered
Chosen Option : 2

Q.11 एक निश्चित भाषा में यदि "SYSTEM" को "SYSMET" लिखा जाता है और "NEARER" को "AENRER" लिखा जाता है। उसी कूट भाषा में "FRACTION" को कैसे लिखा जाएगा?

- Ans
- 1. ACRFTION
 - 2. NOITCARF
 - 3. CARFNOIT
 - 4. TOINCARF

Question ID : 26433081991
Option 1 ID : 264330321797
Option 2 ID : 264330321798
Option 3 ID : 264330321799
Option 4 ID : 264330321800
Status : Answered
Chosen Option : 3

Q.12 उस समुच्चय का चयन कीजिए, जिसमें संख्याएँ उसी तरह से संबंधित हैं, जिस प्रकार दिए गए समुच्चय की संख्याएँ आपस में संबंधित हैं। (नोट: संख्याओं को उसके घटक अंकों में विभाजित किए बिना, पूर्ण संख्याओं पर ही गणितीय संक्रियाएँ की जानी चाहिए। जैसे 13 - मान लीजिए 13 पर गणितीय संक्रियाएँ जैसे कि 13 में जोड़ना/घटाना/गुणा करना आदि किया जा सकता है। 13 को 1 और 3 में तोड़कर और फिर 1 और 3 पर गणितीय संक्रियाएँ करने की अनुमति नहीं है।)
(11, 55, 29)
(8, 40, 20)

- Ans
- 1. (12, 62, 32)
 - 2. (6, 30, 14)
 - 3. (7, 35, 25)
 - 4. (9, 54, 23)

Question ID : 26433078965
Option 1 ID : 264330309875
Option 2 ID : 264330309873
Option 3 ID : 264330309872
Option 4 ID : 264330309874
Status : Answered
Chosen Option : 2

Q.13 दिए गए समीकरण को संतुलित करने के लिए किन दो संख्याओं (अंकों को नहीं) को परस्पर बदलना होगा?

$$28 \times 8 \div 2 + 13 + 30 = 50$$

- Ans
- 1. 8, 28
 - 2. 2, 30
 - 3. 30, 50
 - 4. 2, 8

Question ID : 264330129588

Option 1 ID : 264330507718

Option 2 ID : 264330507721

Option 3 ID : 264330507720

Option 4 ID : 264330507719

Status : Answered

Chosen Option : 4

Q.14 गणितीय चिह्नों के उस सही संयोजन का चयन करें जिसे 'A' के स्थान पर रखने पर दिया गया समीकरण संतुलित हो जाएगा।

$$52 A 12 A 15 A 3 A 6 A 5 A 15$$

- Ans
- 1. -, +, +, x, =, +
 - 2. +, -, +, x, =, +
 - 3. -, +, x, =, +, +
 - 4. -, +, +, =, x, +

Question ID : 264330144861

Option 1 ID : 264330567700

Option 2 ID : 264330567701

Option 3 ID : 264330567699

Option 4 ID : 264330567702

Status : Answered

Chosen Option : 4

Q.15 दो कथनों के बाद दो निष्कर्ष I और II दिए गए हैं। कथनों को सत्य मानते हुए, भले ही वे सामान्य रूप से ज्ञात तथ्यों से भिन्न प्रतीत होते हों, निर्णय लीजिए कि कौन सा/से निष्कर्ष कथनों का तार्किक रूप से अनुसरण करता/करते है/हैं।

कथन:

सभी चाबियाँ, ताले हैं।

सभी ताले, हैंडल हैं।

निष्कर्ष:

I. कुछ ताले, चाबियाँ हैं।

II. कुछ हैंडल, चाबियाँ हैं।

- Ans
- 1. केवल निष्कर्ष II अनुसरण करता है
 - 2. केवल निष्कर्ष I अनुसरण करता है
 - 3. न तो निष्कर्ष I अनुसरण करता है और न ही II अनुसरण करता है
 - 4. निष्कर्ष I और II दोनों अनुसरण करते हैं

Question ID : 264330144956

Option 1 ID : 264330568080

Option 2 ID : 264330568079

Option 3 ID : 264330568082

Option 4 ID : 264330568081

Status : Answered

Chosen Option : 4

Q.16 एक निश्चित कूट भाषा में, 'MARS' को '1752223' के रूप में लिखा जाता है और 'TIDE' को '241389' के रूप में लिखा जाता है। उसी भाषा में 'BABY' को कैसे लिखा जाएगा?

- Ans
- 1. 86425
 - 2. 79523
 - 3. 65216
 - 4. 65629

Question ID : 26433082564
Option 1 ID : 264330324092
Option 2 ID : 264330324089
Option 3 ID : 264330324091
Option 4 ID : 264330324090
Status : Answered
Chosen Option : 4

Q.17 दी गई आकृति में कितने वृत्त हैं?

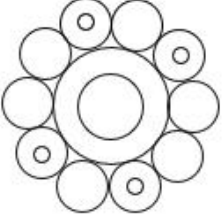

- Ans
- 1. 17
 - 2. 14
 - 3. 15
 - 4. 16

Question ID : 26433068627
Option 1 ID : 264330269022
Option 2 ID : 264330269023
Option 3 ID : 264330269021
Option 4 ID : 264330269020
Status : Answered
Chosen Option : 4

Q.18 दर्पण को नीचे दर्शाए अनुसार MN पर रखे जाने पर दिए गए संयोजन की सही दर्पण छवि का चयन कीजिए।

p e 3 5 b a
M
|
N

- Ans
- ✓ 1. s d 7 Ǝ Ǝ q
 - ✗ 2. a d 7 Ǝ e q
 - ✗ 3. s b 5 Ǝ Ǝ q
 - ✗ 4. s b 7 Ǝ Ǝ p

Question ID : 264330109213

Option 1 ID : 264330429131

Option 2 ID : 264330429130

Option 3 ID : 264330429129

Option 4 ID : 264330429132

Status : Answered

Chosen Option : 1

ixamBee

Prepare 50% Faster

Q.19 दिए गए विकल्पों में से उस आकृति का चयन करें, जो निम्नलिखित शृंखला में

प्रश्नचिह्न (?) को प्रतिस्थापित करेगी।



Ans

✗ 1.



✓ 2.



✗ 3.



✗ 4.



Question ID : 26433087158
Option 1 ID : 264330342269
Option 2 ID : 264330342270
Option 3 ID : 264330342271
Option 4 ID : 264330342272

Status : Answered

Chosen Option : 2

Q.20 निम्नांकित शृंखला में पैटर्न को जारी रखने के लिए प्रश्नचिह्न (?) को किस आकृति द्वारा प्रतिस्थापित किया जाना चाहिए?

M O L E	3 L O M	O 3 L 9	E L 3 O	?
3 9	9 E	E M	M 9	

Ans

✗ 1. M E L 9
3 O

✗ 2. L 3 O E
9 M

✓ 3. 3 E L M
9 O

✗ 4. 9 E 3 O
M L

Question ID : 264330129601

Option 1 ID : 264330507773

Option 2 ID : 264330507770

Option 3 ID : 264330507772

Option 4 ID : 264330507771

Status : Not Answered

Chosen Option : --

Q.21 किसी हॉल की लंबाई और चौड़ाई क्रमशः 16 m और 13 m है। एक कुत्ता हड्डी पकड़ने के लिए एक बार चारों दीवारों के अनुदिश दौड़ता है। कुत्ता कुल कितनी दूरी तय करता है?

Ans ✗ 1. 29 m

✗ 2. 32 m

✓ 3. 58 m

✗ 4. 42 m

Question ID : 264330132105

Option 1 ID : 264330517517

Option 2 ID : 264330517516

Option 3 ID : 264330517518

Option 4 ID : 264330517515

Status : Answered

Chosen Option : 3

Q.22 उस विकल्प का चयन कीजिए जो चौथी संख्या से उसी प्रकार संबंधित है जिस प्रकार पहली संख्या दूसरी संख्या से संबंधित है और पांचवीं संख्या छठी संख्या से संबंधित है?

648 : 8 :: ? : 12 :: 18 : 2

- Ans
- 1. 2648
 - 2. 1840
 - 3. 3240
 - 4. 2028

Question ID : 264330144881

Option 1 ID : 264330567780

Option 2 ID : 264330567779

Option 3 ID : 264330567781

Option 4 ID : 264330567782

Status : Answered

Chosen Option : 4

Q.23 एक पासे के विभिन्न फलकों पर 1, 2, 3, 4, 5 और 6 लिखे गए हैं। उसी पासे की तीन अलग-अलग स्थितियाँ नीचे दर्शाई गई हैं। '1' दर्शाने वाले फलक के विपरीत फलक पर कौन-सी संख्या है?

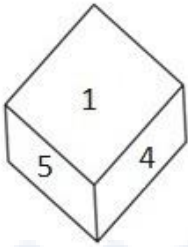

Figure 1

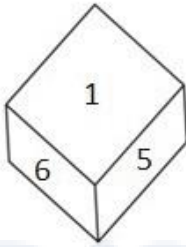

Figure 2

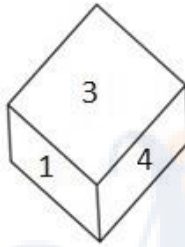

Figure 3

- Ans
- 1. 3
 - 2. 4
 - 3. 6
 - 4. 2

Question ID : 26433080732

Option 1 ID : 264330316862

Option 2 ID : 264330316863

Option 3 ID : 264330316864

Option 4 ID : 264330316861

Status : Answered

Chosen Option : 4

Q.24 13 जनवरी 2021 से 23 अगस्त 2021 तक दिनों की संख्या की गणना करें (दोनों दिन शामिल करके)?

- Ans
- 1. 227
 - 2. 225
 - 3. 221
 - 4. 223

Question ID : 264330144944

Option 1 ID : 264330568031

Option 2 ID : 264330568032

Option 3 ID : 264330568034

Option 4 ID : 264330568033

Status : Answered

Chosen Option : 4

Q.25 दिए गए विकल्पों में से उस संख्या का चयन कीजिए जो निम्नलिखित श्रृंखला में प्रश्न चिह्न (?) के स्थान पर आ सकती है।
64, 72, 81, 91, ?

- Ans 1. 104
 2. 102
 3. 100
 4. 105

Question ID : 264330112665
Option 1 ID : 264330442747
Option 2 ID : 264330442746
Option 3 ID : 264330442745
Option 4 ID : 264330442748
Status : Answered
Chosen Option : 2

Q.26 यदि 'A' का अर्थ '+' है, 'B' का अर्थ '×' है, 'C' का अर्थ '÷' है और 'D' का अर्थ '-' है, तो निम्नलिखित समीकरण में प्रश्न चिह्न (?) के स्थान पर क्या आएगा?
3 B 29 D 1 C 9 A 9 = ?

- Ans 1. 69
 2. 87
 3. 88
 4. 89

Question ID : 264330141899
Option 1 ID : 264330555917
Option 2 ID : 264330555918
Option 3 ID : 264330555915
Option 4 ID : 264330555916
Status : Answered
Chosen Option : 2

Q.27 दिए गए समीकरण को संतुलित करने के लिए किन दो संख्याओं (अंकों को नहीं) को परस्पर बदलना होगा?

$$(96 \div 12) + (7)^2 + 18 = 112 - (16 \times 3) - (69 \div 23)$$

- Ans 1. 7 और 3
 2. 18 और 16
 3. 12 और 16
 4. 7 और 18

Question ID : 264330144860
Option 1 ID : 264330567695
Option 2 ID : 264330567698
Option 3 ID : 264330567697
Option 4 ID : 264330567696
Status : Answered
Chosen Option : 3

Q.28 एक कागज को नीचे दर्शाए गए अनुसार मोड़ा और काटा जाता है। खोलने के बाद यह कैसा दिखाई देगा?

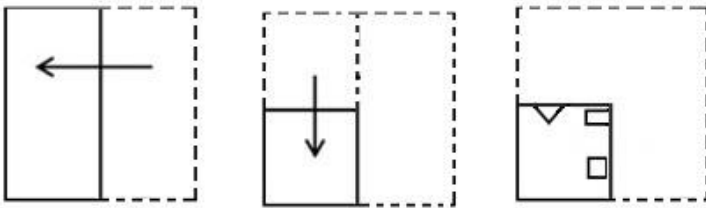

Ans

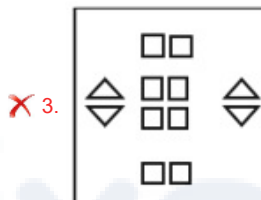
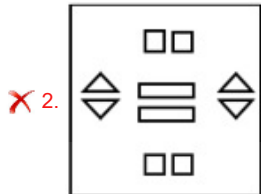
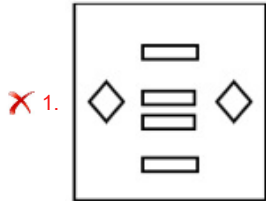

Question ID : 264330106337

Option 1 ID : 264330417649

Option 2 ID : 264330417652

Option 3 ID : 264330417650

Option 4 ID : 264330417651

Status : Answered

Chosen Option : 4

Q.29 उस विकल्प का चयन कीजिए जो पाँचवीं संख्या से उसी प्रकार संबंधित हो, जैसे दूसरी संख्या पहली संख्या से संबंधित है और चौथी संख्या तीसरी संख्या से संबंधित है।
100 : 45 :: 200 : 70 : 300 : ?

Ans ✗ 1. 98

✗ 2. 105

✗ 3. 200

✓ 4. 95

Question ID : 26433089556

Option 1 ID : 264330351726

Option 2 ID : 264330351727

Option 3 ID : 264330351728

Option 4 ID : 264330351725

Status : Answered

Chosen Option : 4

Q.30 आठ लड़कियां - L, M, N, O, P, Q, R और S - दो पंक्तियों में बैठी थीं, जिनमें से एक पंक्ति उत्तर की ओर अभिमुख है और दूसरी पंक्ति दक्षिण की ओर अभिमुख है। प्रत्येक पंक्ति में केवल चार कुर्सियाँ थीं। आसन्न लड़कियों के बीच समान दूरी है। एक पंक्ति में प्रत्येक व्यक्ति, दूसरी पंक्ति के किसी अन्य व्यक्ति के सामने है। Q और P एक-दूसरे के तिर्यक रूप से सामने हैं। M, P के सामने है। R, L के ठीक दाएं पड़ोस में है। S, M के दाएं दूसरे स्थान पर है। N, पंक्ति के किसी एक छोर पर है। O के सामने निम्नलिखित में से कौन सी लड़की बैठी है?

- Ans
- 1. L
 - 2. N
 - 3. S
 - 4. R

Question ID : 26433091577
 Option 1 ID : 264330359673
 Option 2 ID : 264330359675
 Option 3 ID : 264330359676
 Option 4 ID : 264330359674
 Status : Answered
 Chosen Option : 4

Q.31 दिए गए विकल्पों में से उस संख्या का चयन कीजिए जो निम्नलिखित श्रृंखला में प्रश्न चिह्न (?) के स्थान पर आ सकती है।
 73, 70, 64, 55, ?

- Ans
- 1. 45
 - 2. 46
 - 3. 43
 - 4. 42

Question ID : 264330112673
 Option 1 ID : 264330442777
 Option 2 ID : 264330442779
 Option 3 ID : 264330442780
 Option 4 ID : 264330442778
 Status : Answered
 Chosen Option : 3

Q.32 निम्नलिखित शब्दों को तार्किक और अर्थपूर्ण क्रम में दर्शाने वाले सही विकल्प का चयन करें।

1. पाक्षिक
2. त्रैमासिक
3. मासिक
4. द्वि-वार्षिक
5. वार्षिक

- Ans
- 1. 1, 3, 2, 4, 5
 - 2. 5, 3, 1, 2, 4
 - 3. 1, 3, 5, 2, 4
 - 4. 5, 1, 3, 4, 2

Question ID : 264330132911
 Option 1 ID : 264330520704
 Option 2 ID : 264330520706
 Option 3 ID : 264330520703
 Option 4 ID : 264330520705
 Status : Answered
 Chosen Option : 1

Q.33 निम्नलिखित में से उस समुच्चय का चयन कीजिए, जिसमें संख्याएँ उसी प्रकार से संबंधित हैं, जिस प्रकार दिए गए समुच्चय की संख्याएँ संबंधित हैं।
(नोट: संख्याओं को उसके घटक अंकों में विभाजित किए बिना, पूर्ण संख्याओं पर ही गणितीय संक्रियाएँ की जानी चाहिए। जैसे 13 - मान लीजिए 13 पर गणितीय संक्रियाएँ जैसे कि 13 में जोड़ना/घटाना/गुणा करना आदि किया जा सकता है। 13 को 1 और 3 में तोड़कर और फिर 1 और 3 पर गणितीय संक्रियाएँ करने की अनुमति नहीं है।)
(16, 400, 4)
(10, 256, 6)

- Ans
- 1. (13, 497, 4)
 - 2. (11, 388, 6)
 - 3. (12, 441, 9)
 - 4. (15, 422, 9)

Question ID : 26433083122
Option 1 ID : 264330326322
Option 2 ID : 264330326324
Option 3 ID : 264330326323
Option 4 ID : 264330326321
Status : Answered
Chosen Option : 3

Q.34 उस शब्द-युग्म का चयन करें जो नीचे दिए गए शब्दों के युग्म में व्यक्त किए गए संबंध के समान संबंध का सबसे अच्छा निरूपण करता है।
(शब्दों को अर्थपूर्ण अंग्रेजी शब्दों के रूप में माना जाना चाहिए और शब्द में अक्षरों की संख्या/व्यंजन/स्वरों की संख्या के आधार पर एक दूसरे से संबंधित नहीं होना चाहिए)

माल : स्टॉक

- Ans
- 1. दंगाई : उग्र भीड़
 - 2. सामग्री : उपभोक्ता
 - 3. लोग : अपार्टमेंट
 - 4. संगीतकार : संगीत

Question ID : 264330144913
Option 1 ID : 264330567908
Option 2 ID : 264330567910
Option 3 ID : 264330567907
Option 4 ID : 264330567909
Status : Answered
Chosen Option : 1

Q.35 उस विकल्प का चयन करें जिसमें दी गई आकृति अंतर्निहित है (घुमाने की अनुमति नहीं है)।

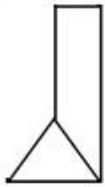

Ans

✗ 1.

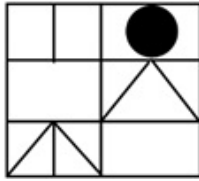

✗ 2.

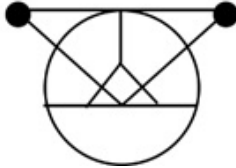

✗ 3.

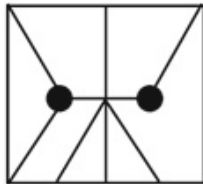

✓ 4.



Question ID : 264330111655

Option 1 ID : 264330438705

Option 2 ID : 264330438708

Option 3 ID : 264330438707

Option 4 ID : 264330438706

Status : Answered

Chosen Option : 4

Q.36 निम्नलिखित में से कौन-सी संख्या दी गई श्रृंखला में प्रश्न चिह्न (?) को प्रतिस्थापित करेगी?
420, 342, 342, ?, 272

Ans ✗ 1. 284

✗ 2. 292

✓ 3. 272

✗ 4. 324

Question ID : 26433082433

Option 1 ID : 264330323568

Option 2 ID : 264330323566

Option 3 ID : 264330323565

Option 4 ID : 264330323567

Status : Answered

Chosen Option : 3

Q.37 'A + B' का अर्थ है 'A, B का बेटा है'
 'A - B' का अर्थ है 'A, B की माँ है'
 'A × B' का अर्थ है 'A, B का पिता है'
 'A ÷ B' का अर्थ है 'A, B का भाई है'
 यदि 'F × G ÷ K - M + S × W' है, तो निम्नलिखित में से कौन-सा कथन सही नहीं है?

- Ans 1. G, S का साला है।
 2. S, K का पति है।
 3. S, G का भाई है।
 4. M, G का भांजा है।

Question ID : 264330102487
 Option 1 ID : 264330402380
 Option 2 ID : 264330402379
 Option 3 ID : 264330402377
 Option 4 ID : 264330402378
 Status : Answered
 Chosen Option : 3

Q.38 दिए गए विकल्पों में से उस संख्या का चयन कीजिए जो निम्नलिखित श्रृंखला में प्रश्न चिह्न (?) के स्थान पर आ सकती है।
 47, 47, 48, 50, ?

- Ans 1. 51
 2. 53
 3. 55
 4. 52

Question ID : 264330112662
 Option 1 ID : 264330442733
 Option 2 ID : 264330442735
 Option 3 ID : 264330442736
 Option 4 ID : 264330442734
 Status : Answered
 Chosen Option : 2

Q.39 यदि '+' का अर्थ '-', '-' का अर्थ '+', '÷' का अर्थ '+', और '×' का अर्थ '-' है, तो निम्नलिखित व्यंजक का मान ज्ञात करें।

$$33 + 14 - 2 \times 17 \div 71 = ?$$

- Ans 1. 80
 2. 90
 3. 100
 4. 70

Question ID : 264330130353
 Option 1 ID : 264330510525
 Option 2 ID : 264330510523
 Option 3 ID : 264330510524
 Option 4 ID : 264330510526
 Status : Answered
 Chosen Option : 1

Q.40 K, L, M, W, X, Y और Z ने एक परीक्षा में अलग-अलग अंक प्राप्त किए। K ने केवल दो व्यक्तियों से अधिक अंक प्राप्त किए। Y ने केवल L और W से कम अंक प्राप्त किए। M ने Z से अधिक, लेकिन X से कम अंक प्राप्त किए। W ने उच्चतम अंक प्राप्त नहीं किए। कितने लोगों ने X से कम अंक प्राप्त किए?

Ans 1. तीन

2. तीन से अधिक

3. एक

4. कोई नहीं

Question ID : 264330131660

Option 1 ID : 264330515739

Option 2 ID : 264330515742

Option 3 ID : 264330515741

Option 4 ID : 264330515740

Status : Answered

Chosen Option : 1

Q.41 दी गई श्रृंखला को पूरा करने के लिए कौन-सा अक्षर-समूह प्रश्न चिह्न (?) को प्रतिस्थापित करेगा?
RXBG, OVEK, ?, IRKS, FPNW

Ans 1. LTIO

2. LVHO

3. LTHO

4. LUHO

Question ID : 26433067963

Option 1 ID : 264330266366

Option 2 ID : 264330266364

Option 3 ID : 264330266367

Option 4 ID : 264330266365

Status : Answered

Chosen Option : 3

Q.42 निम्नलिखित चार अक्षर-समूहों में से तीन एक निश्चित तरीके से आपस में संगत है, जबकि कोई एक उनसे असंगत है। असंगत अक्षर-समूह का चयन करें।

Ans 1. MNOL

2. FUHS

3. GTIR

4. CXEW

Question ID : 26433057232

Option 1 ID : 264330223914

Option 2 ID : 264330223913

Option 3 ID : 264330223912

Option 4 ID : 264330223915

Status : Answered

Chosen Option : 4

Q.43 दिए गए समीकरण को संतुलित करने के लिए किन दो संख्याओं (अंकों को नहीं) को परस्पर बदलना होगा?

$$13 \times 4 \div 26 + 15 - 18 = 5$$

- Ans 1. 13, 5
 2. 15, 18
 3. 18, 26
 4. 15, 5

Question ID : 264330129585

Option 1 ID : 264330507706

Option 2 ID : 264330507708

Option 3 ID : 264330507707

Option 4 ID : 264330507709

Status : Answered

Chosen Option : 2

Q.44 उस विकल्प का चयन करें, जो छठी संख्या से उसी प्रकार संबंधित है, जिस प्रकार पहली संख्या दूसरी संख्या से और तीसरी संख्या चौथी संख्या से संबंधित है।
48 : 2 :: 448 : 6 :: ? : 8

- Ans 1. 512
 2. 729
 3. 900
 4. 881

Question ID : 26433087205

Option 1 ID : 264330342457

Option 2 ID : 264330342458

Option 3 ID : 264330342460

Option 4 ID : 264330342459

Status : Answered

Chosen Option : 2

Q.45 एक लड़की की ओर इशारा करते हुए अभिषेक ने कहा "वह मेरे दादा/नाना की इकलौती संतान की पुत्री है"। लड़की का अभिषेक से क्या संबंध है?

- Ans 1. माँ
 2. बुआ
 3. बहन
 4. पुत्री

Question ID : 264330132337

Option 1 ID : 264330518443

Option 2 ID : 264330518446

Option 3 ID : 264330518444

Option 4 ID : 264330518445

Status : Answered

Chosen Option : 3

Q.46 सात लोग A, B, C, D, E, F और G उत्तर की तरफ मुंह करके एक सीधी पंक्ति में बैठे हुए हैं। D के बाएं केवल 1 व्यक्ति बैठा है। A, D के ठीक बगल में बैठा है। F और D के बीच में केवल 2 लोग बैठे हैं। C और G के बीच में केवल 3 लोग बैठे हैं। B, G का निकटतम पड़ोसी नहीं है। E और A के बीच में केवल 2 लोग बैठे हैं।

G के ठीक दाएं कौन बैठा है?

- Ans 1. F
 2. E
 3. D
 4. A

Question ID : 264330144962

Option 1 ID : 264330568104

Option 2 ID : 264330568105

Option 3 ID : 264330568103

Option 4 ID : 264330568106

Status : Answered

Chosen Option : 2



Prepare 50% Faster

Q.47 उस विकल्प का चयन करें जिसमें दी गई आकृति अंतर्निहित है (घुमाने की अनुमति नहीं है)।

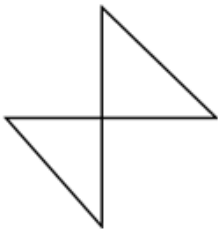

Ans

✗ 1.

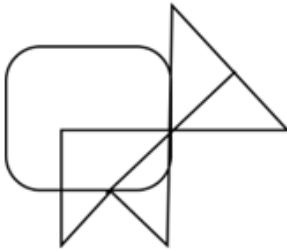

✓ 2.



✗ 3.

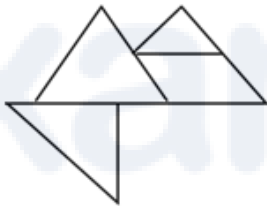

✗ 4.

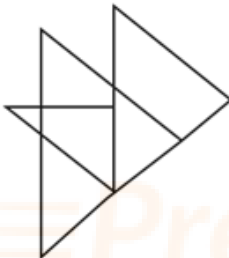

Question ID : 264330132509

Option 1 ID : 264330519134

Option 2 ID : 264330519131

Option 3 ID : 264330519133

Option 4 ID : 264330519132

Status : Answered

Chosen Option : 2

Q.48 निम्नलिखित में से कौन-सा पद दी गई श्रृंखला में प्रश्न-चिह्न (?) को प्रतिस्थापित करेगा?
UUW, WWY, YYA, AAC, ?

- Ans 1. CCE
 2. LLM
 3. CDJ
 4. AAF

Question ID : 26433090154
Option 1 ID : 264330354094
Option 2 ID : 264330354095
Option 3 ID : 264330354093
Option 4 ID : 264330354096
Status : Answered
Chosen Option : 1

Q.49 तीन कथनों के बाद दो निष्कर्ष I और II दिए गए हैं। कथनों को सत्य मानते हुए, भले ही वे सामान्य रूप से ज्ञात तथ्यों से भिन्न प्रतीत होते हों, निर्णय लीजिए कि कौन-सा/से निष्कर्ष कथनों का तार्किक रूप से अनुसरण करता है/करते हैं।

कथन:
सभी H, G हैं।
सभी V, H हैं।
कुछ V, I हैं।
निष्कर्ष:

- I. कम से कम कुछ G, I हैं।
II. सभी I के H होने की संभावना है।

- Ans 1. केवल निष्कर्ष I अनुसरण करता है
 2. निष्कर्ष I और II दोनों अनुसरण करते हैं
 3. या तो निष्कर्ष I अनुसरण करता है या II अनुसरण करता है
 4. न तो निष्कर्ष I अनुसरण करता है और न ही II अनुसरण करता है

Question ID : 26433081303
Option 1 ID : 264330319057
Option 2 ID : 264330319060
Option 3 ID : 264330319058
Option 4 ID : 264330319059
Status : Answered
Chosen Option : 2

Q.50 उस विकल्प का चयन कीजिए जो नीचे दिए गए शब्दों के उस सही क्रम को दर्शाता है, जिस क्रम में वे अंग्रेजी शब्दकोश में आएंगे।

1. Legerity
2. Legitimate
3. Legislation
4. Legendary
5. Legalist
6. Legging

- Ans 1. 5, 4, 6, 2, 1, 3
 2. 5, 4, 1, 2, 6, 3
 3. 5, 4, 6, 3, 1, 2
 4. 5, 4, 1, 6, 3, 2

Question ID : 264330144931
Option 1 ID : 264330567982
Option 2 ID : 264330567981
Option 3 ID : 264330567979
Option 4 ID : 264330567980
Status : Answered
Chosen Option : 4

Q.1 'आई नो व्हाई द केज्ड बर्ड सिंग्स (I Know Why the Caged Bird Sings)' _____ की आत्मकथा है।

- Ans
- 1. पैट्री शि लॉकवुड
 - 2. मिशेल ओबामा
 - 3. माया एंजेलो
 - 4. डॉली अल्डरटन

Question ID : 264330144841
Option 1 ID : 264330567621
Option 2 ID : 264330567619
Option 3 ID : 264330567620
Option 4 ID : 264330567622
Status : Answered
Chosen Option : 2

Q.2 भारत की भौतिक विशेषताओं के संदर्भ में, 'कयाल' _____ हैं।

- Ans
- 1. घाटियाँ
 - 2. अप्रवाही जल
 - 3. पहाड़ियाँ
 - 4. पर्वतीय दरें

Question ID : 264330166800
Option 1 ID : 264330654236
Option 2 ID : 264330654235
Option 3 ID : 264330654238
Option 4 ID : 264330654237
Status : Answered
Chosen Option : 2

Q.3 'द अनफॉरगेटेबल्स' किस राजल गायक के अर्ध-शास्त्रीय संगीत का संग्रह था?

- Ans
- 1. तलत महमूद
 - 2. जगजीत सिंह
 - 3. मल्लिका पुखराज
 - 4. मेहदी हसन

Question ID : 26433064243
Option 1 ID : 264330251565
Option 2 ID : 264330251564
Option 3 ID : 264330251567
Option 4 ID : 264330251566
Status : Not Answered
Chosen Option : --

Q.4 1927 में डॉ. बी. आर. आंबेडकर द्वारा निम्नलिखित में से कौन-सा सत्याग्रह शुरू किया गया था?

- Ans
- 1. मुलशी सत्याग्रह
 - 2. नासिक मंदिर सत्याग्रह
 - 3. धरासन सत्याग्रह
 - 4. महाड़ सत्याग्रह

Question ID : 264330111401
Option 1 ID : 264330437689
Option 2 ID : 264330437690
Option 3 ID : 264330437691
Option 4 ID : 264330437692
Status : Answered
Chosen Option : 3

Q.5 क्लोरोफ्लोरोकार्बन (CFC) के बारे में निम्नलिखित में से कौन-सा दावा सही है?

- Ans
- ✓ 1. CFC का उपयोग प्रशीतक के रूप में किया जाता है
 - ✗ 2. CFC का उपयोग हवाई जहाजों के लिए ईंधन के रूप में किया जाता है
 - ✗ 3. CFC का उपयोग क्षोभमंडल के सुधारक के रूप में किया जाता है
 - ✗ 4. CFC का उपयोग ओजोन परत के सुधारक के रूप में किया जाता है

Question ID : 264330131721
Option 1 ID : 264330515986
Option 2 ID : 264330515985
Option 3 ID : 264330515983
Option 4 ID : 264330515984
Status : Answered
Chosen Option : 1

Q.6 हिंदू पौराणिक कथाओं के अनुसार गुड़ी पड़वा उत्सव में गुड़ी का क्या अर्थ है?

- Ans
- ✗ 1. शांति का प्रतीक
 - ✓ 2. विजय का प्रतीक
 - ✗ 3. शक्ति का प्रतीक
 - ✗ 4. सद्भाव का प्रतीक

Question ID : 26433072645
Option 1 ID : 264330284843
Option 2 ID : 264330284840
Option 3 ID : 264330284842
Option 4 ID : 264330284841
Status : Answered
Chosen Option : 1

Q.7 निम्नलिखित में से किस अनुच्छेद के तहत 'समान न्याय और मुफ्त कानूनी सहायता' प्रदान करने का प्रावधान है?

- Ans
- ✗ 1. अनुच्छेद 43 A
 - ✗ 2. अनुच्छेद 43 B
 - ✗ 3. अनुच्छेद 48 A
 - ✓ 4. अनुच्छेद 39 A

Question ID : 264330112780
Option 1 ID : 264330443206
Option 2 ID : 264330443207
Option 3 ID : 264330443208
Option 4 ID : 264330443205
Status : Answered
Chosen Option : 4

Q.8 भारत के अधिकांश शास्त्रीय नृत्य रूपों की उत्पत्ति _____ से हुई है।

- Ans
- ✗ 1. अथर्ववेद
 - ✗ 2. यजुर्वेद
 - ✗ 3. अथशास्त्र
 - ✓ 4. नाट्यशास्त्र

Question ID : 264330109273
Option 1 ID : 264330429369
Option 2 ID : 264330429371
Option 3 ID : 264330429370
Option 4 ID : 264330429372
Status : Answered
Chosen Option : 2

Q.9 'अब्बा: गॉड्स ग्रेटेस्ट गिफ्ट टू अस' किस महान संगीतकार के पुत्रों द्वारा लिखा गया था?

- Ans 1. अमजद अली खान
 2. आमिर खान
 3. अली अकबर खान
 4. बिस्मिल्लाह खान

Question ID : 26433064249
Option 1 ID : 264330251590
Option 2 ID : 264330251591
Option 3 ID : 264330251588
Option 4 ID : 264330251589
Status : Answered
Chosen Option : 1

Q.10 1990-91 के दौरान, इस्पात के उत्पादन में सार्वजनिक क्षेत्र और निजी क्षेत्र की हिस्सेदारी क्रमशः _____ थी।

- Ans 1. 55% और 45%
 2. 49% और 51%
 3. 46% और 54%
 4. 40% और 60%

Question ID : 26433064529
Option 1 ID : 264330252711
Option 2 ID : 264330252710
Option 3 ID : 264330252709
Option 4 ID : 264330252708
Status : Answered
Chosen Option : 4

Q.11 2011 की जनगणना के अनुसार, कुल वैश्विक आबादी की कितने प्रतिशत जनसंख्या भारत में है?

- Ans 1. 14.68%
 2. 15.45%
 3. 20.32%
 4. 17.5%

Question ID : 264330119911
Option 1 ID : 264330469920
Option 2 ID : 264330469922
Option 3 ID : 264330469919
Option 4 ID : 264330469921
Status : Answered
Chosen Option : 4

Q.12 जनवरी 2023 तक प्राप्त जानकारी के अनुसार, हिमाचल प्रदेश के मुख्यमंत्री कौन हैं?

- Ans
- 1. पुष्कर सिंह धामी
 - 2. अशोक गहलोत
 - 3. भूपेश बघेल
 - 4. सुखविंदर सिंह सुक्खू

Question ID : 264330165223
 Option 1 ID : 264330647992
 Option 2 ID : 264330647994
 Option 3 ID : 264330647991
 Option 4 ID : 264330647993
 Status : Answered
 Chosen Option : 4

Q.13 1803 में समीकरण $C = KP_{gas}$ किसके द्वारा प्रतिपादित किया गया था?

- Ans
- 1. रॉबर्ट बॉयल
 - 2. जैक्स चार्ल्स
 - 3. एडम मैरियट
 - 4. विलियम हेनरी

Question ID : 264330141687
 Option 1 ID : 264330555069
 Option 2 ID : 264330555070
 Option 3 ID : 264330555068
 Option 4 ID : 264330555067
 Status : Not Answered
 Chosen Option : --

Q.14 रंगास्वामी कप किस खेल से संबंधित है?

- Ans
- 1. हॉकी
 - 2. फुटबॉल
 - 3. बास्केटबाल
 - 4. वालीबाल

Question ID : 264330110329
 Option 1 ID : 264330433595
 Option 2 ID : 264330433594
 Option 3 ID : 264330433596
 Option 4 ID : 264330433593
 Status : Answered
 Chosen Option : 1

Q.15 मार्च 2023 तक प्राप्त जानकारी के अनुसार, केंद्रीय युवा कार्यक्रम और खेल मंत्री कौन हैं?

- Ans
- 1. अनुराग ठाकुर
 - 2. एस. जयशंकर
 - 3. स्मृति ईरानी
 - 4. किरेन रिजिजू

Question ID : 264330165215
 Option 1 ID : 264330647961
 Option 2 ID : 264330647959
 Option 3 ID : 264330647962
 Option 4 ID : 264330647960
 Status : Answered
 Chosen Option : 1

Q.16 भारत में 1960 से 1980 के दशक में 'परमिट लाइसेंस राज' का प्रमुख उद्देश्य क्या था?

- Ans
- 1. सरकार द्वारा केवल विदेशी कंपनियों को भारत में माल/वस्तुएं बेचने की अनुमति देना
 - 2. सरकार द्वारा सार्वजनिक क्षेत्र के उपक्रमों को वस्तुओं का उत्पादन करने की अनुमति देना
 - 3. सरकार द्वारा निजी कंपनियों को वस्तुएं बनाने की अनुमति देना
 - 4. सरकार द्वारा राष्ट्रीयकृत बैंकों को निजी कंपनियों को ऋण देने की अनुमति देना

Question ID : 264330111745

Option 1 ID : 264330439067

Option 2 ID : 264330439066

Option 3 ID : 264330439065

Option 4 ID : 264330439068

Status : Not Answered

Chosen Option : --

Q.17 भारत का सबसे बड़ा स्तूप निम्नलिखित में से कौन-सा है?

- Ans
- 1. केसरिया स्तूप
 - 2. शांति स्तूप
 - 3. महा स्तूप
 - 4. सांची स्तूप

Question ID : 26433066553

Option 1 ID : 264330260739

Option 2 ID : 264330260737

Option 3 ID : 264330260736

Option 4 ID : 264330260738

Status : Answered

Chosen Option : 4

Q.18 एनी बेसेंट की 'होम रूल लीग' भारत के निम्नलिखित में से किस स्थान पर केंद्रित थी?

- Ans
- 1. बनारस
 - 2. बॉम्बे
 - 3. कलकत्ता
 - 4. मद्रास

Question ID : 264330165395

Option 1 ID : 264330648660

Option 2 ID : 264330648662

Option 3 ID : 264330648661

Option 4 ID : 264330648659

Status : Answered

Chosen Option : 3

Q.19 अनिदिता नियोगी अनाम ने निम्नलिखित में से किस श्रेणी में राष्ट्रीय नृत्य शिरोमणि पुरस्कार प्राप्त किया?

- Ans
- 1. मणिपुरी
 - 2. भरतनाट्यम
 - 3. कथक
 - 4. कुचिपुड़ी

Question ID : 264330157014

Option 1 ID : 264330615434

Option 2 ID : 264330615432

Option 3 ID : 264330615433

Option 4 ID : 264330615431

Status : Not Answered

Chosen Option : --

Q.20 हॉर्नबिल महोत्सव के संबंध में निम्नलिखित में से कौन-से कथन सत्य हैं?

A. हॉर्नबिल महोत्सव उत्तर-पूर्वी राज्य नागालैंड में मनाया जाता है।

B. यह महोत्सव जनवरी के महीने में मनाया जाता है।

C. इस महोत्सव के नाम की व्युत्पत्ति इस राज्य की लोककथाओं में प्रमुखता से वर्णित हॉर्नबिल नामक एक पक्षी के नाम से हुई है।

Ans 1. B और C दोनों

2. A और C दोनों

3. A और B दोनों

4. A, B और C

Question ID : 264330114559

Option 1 ID : 264330450322

Option 2 ID : 264330450323

Option 3 ID : 264330450324

Option 4 ID : 264330450321

Status : Answered

Chosen Option : 4

Q.21 राज्य की विधान सभा के समक्ष प्रतिवर्ष वार्षिक वित्तीय विवरण कौन प्रस्तुत करवाएगा?

Ans 1. मुख्यमंत्री

2. उपमुख्यमंत्री

3. राज्यपाल

4. राष्ट्रपति

Question ID : 264330130790

Option 1 ID : 264330512271

Option 2 ID : 264330512274

Option 3 ID : 264330512273

Option 4 ID : 264330512272

Status : Answered

Chosen Option : 1

Q.22 वर्ष 2011 की जनगणना के अनुसार भारत की साक्षरता दर क्या है?

Ans 1. 72.98%

2. 65.46%

3. 82.14%

4. 16.68%

Question ID : 264330166815

Option 1 ID : 264330654296

Option 2 ID : 264330654297

Option 3 ID : 264330654295

Option 4 ID : 264330654298

Status : Answered

Chosen Option : 1

Q.23 संरचनात्मक भूविज्ञान किससे संबंधित है?

- Ans
- 1. शैलों की आयु
 - 2. ज्वालामुखी निर्माण के कारण
 - 3. शैल संरचनाओं के विकास के रूप, वर्गीकरण, तंत्र और कारण
 - 4. मृदा के घटकों और उसकी रासायनिक प्रकृति

Question ID : 264330111916

Option 1 ID : 264330439749

Option 2 ID : 264330439752

Option 3 ID : 264330439750

Option 4 ID : 264330439751

Status : Not Answered

Chosen Option : --

Q.24 संश्लिष्ट फाइबर, प्रत्यास्थलक, पॉलिमर और पृष्ठसक्रियक मध्यवर्ती सभी _____ उद्योगों के उपसमूह हैं।

- Ans
- 1. औषध
 - 2. चीनी
 - 3. टेक्सटाइल
 - 4. पेट्रो क्लिकल

Question ID : 264330163216

Option 1 ID : 264330640178

Option 2 ID : 264330640177

Option 3 ID : 264330640176

Option 4 ID : 264330640175

Status : Answered

Chosen Option : 3

Q.25 निम्नलिखित में से किसे खाद्य में एक रासायनिक खतरा माना जाता है?

- Ans
- 1. कीटनाशक अवशेष
 - 2. पत्थर
 - 3. आभूषण
 - 4. रेत

Question ID : 264330131705

Option 1 ID : 264330515921

Option 2 ID : 264330515919

Option 3 ID : 264330515920

Option 4 ID : 264330515922

Status : Answered

Chosen Option : 1

Q.26 भारत में हवाई परिवहन निम्नलिखित में से किस वर्ष में शुरू किया गया था?

- Ans
- 1. 1954
 - 2. 1948
 - 3. 1911
 - 4. 1932

Question ID : 264330163223

Option 1 ID : 264330640206

Option 2 ID : 264330640205

Option 3 ID : 264330640203

Option 4 ID : 264330640204

Status : Answered

Chosen Option : 2

Q.27 निम्नलिखित में से किसे लोक नृत्य के लिए पद्म श्री 2023 से सम्मानित किया गया है?

- Ans
- 1. अजय कुमार मंडावी
 - 2. शांति परमार
 - 3. कृष्णा पटेल
 - 4. रानी मचैया

Question ID : 264330157013
Option 1 ID : 264330615427
Option 2 ID : 264330615429
Option 3 ID : 264330615430
Option 4 ID : 264330615428
Status : Answered
Chosen Option : 2

Q.28 ऊर्जा संरक्षण (संशोधन) विधेयक, 2022 में निम्नलिखित में से क्या शामिल नहीं है?

- Ans
- 1. नामित उपभोक्ताओं के लिए एक गैर-जीवाश्म-ईंधन जनादेश
 - 2. ऊर्जा खपत मानकों के दायरे को कम करना
 - 3. कार्बन क्रेडिट ट्रेडिंग योजना की स्थापना
 - 4. ब्यूरो ऑफ एनर्जी एफिशिएंसी (BEE) गवर्निंग काउंसिल के विस्तार का निर्णय

Question ID : 264330158488
Option 1 ID : 264330621311
Option 2 ID : 264330621314
Option 3 ID : 264330621312
Option 4 ID : 264330621313
Status : Not Answered
Chosen Option : --

Q.29 निम्नलिखित में से कौन-सा वेद कृष्ण और शुक्ल दो पाठ भेदों में उपलब्ध है, और उसमें सार्वजनिक या व्यक्तिगत रूप से की जाने वाली अनुष्ठानों विधियों का वर्णन है?

- Ans
- 1. यजुर्वेद
 - 2. सामवेद
 - 3. ऋग्वेद
 - 4. अथर्ववेद

Question ID : 264330165334
Option 1 ID : 264330648418
Option 2 ID : 264330648416
Option 3 ID : 264330648417
Option 4 ID : 264330648415
Status : Answered
Chosen Option : 1

Q.30 फरवरी 2023 में, नीति आयोग के नए मुख्य कार्यकारी अधिकारी के रूप में कार्यभार किसने ग्रहण किया?

- Ans
- 1. टी.वी. सोमनाथन
 - 2. अजय कुमार भल्ला
 - 3. अमिताभ कांत
 - 4. बी.वी.आर. सुब्रह्मण्यम

Question ID : 264330158507
Option 1 ID : 264330621389
Option 2 ID : 264330621390
Option 3 ID : 264330621387
Option 4 ID : 264330621388
Status : Answered
Chosen Option : 4

Q.31 मुद्रा आपूर्ति की अवधारणा में, M4 _____ को संदर्भित करता है।

- Ans
- ✓ 1. M3 + कुल डाकघर जमाशियां
 - ✗ 2. जनता के पास उपलब्ध मुद्रा
 - ✗ 3. M1 + डाकघर बचत जमाशियां
 - ✗ 4. M1+ बैंकों में जनता की सावधि जमाशियां

Question ID : 264330109977

Option 1 ID : 264330432186

Option 2 ID : 264330432188

Option 3 ID : 264330432185

Option 4 ID : 264330432187

Status : Not Answered

Chosen Option : --

Q.32 हड़प्पा नगरों के निम्नलिखित समूहों में से किस समूह में अग्निवेदियां पाई गई हैं?

- Ans
- ✗ 1. बनावली और चन्हुदड़ो
 - ✗ 2. मोहनजोदड़ो और हड़प्पा
 - ✓ 3. कालीबंगा और लोथल
 - ✗ 4. मोहनजोदड़ो और धोलावीरा

Question ID : 264330141809

Option 1 ID : 264330555555

Option 2 ID : 264330555557

Option 3 ID : 264330555558

Option 4 ID : 264330555556

Status : Not Answered

Chosen Option : --

Q.33 इंडोनेशिया में जन्मे अमेरिकी कोशिकानुवंशिकी विज्ञानी जो हिन तजियो (Joe Hin Tjio) ने 1956 में घोषणा की कि मानव गुणसूत्रों की सही संख्या _____ है।

- Ans
- ✗ 1. 49
 - ✓ 2. 46
 - ✗ 3. 35
 - ✗ 4. 40

Question ID : 264330113468

Option 1 ID : 264330445960

Option 2 ID : 264330445959

Option 3 ID : 264330445957

Option 4 ID : 264330445958

Status : Not Answered

Chosen Option : --

Q.34 निम्नलिखित में से कौन-सा प्रोटोजोआ नहीं है?

- Ans
- ✓ 1. स्काइफा
 - ✗ 2. अमीबा
 - ✗ 3. प्लाज्मोडियम
 - ✗ 4. यूस्लीना

Question ID : 264330111879

Option 1 ID : 264330439601

Option 2 ID : 264330439602

Option 3 ID : 264330439604

Option 4 ID : 264330439603

Status : Answered

Chosen Option : 1

Q.35 सत्रीया के एकांकी नाटक को क्या कहते हैं?

- Ans
- 1. विशेषम नाट
 - 2. अनंत नाट
 - 3. एकम नाट
 - 4. अंकिया नाट

Question ID : 264330109274

Option 1 ID : 264330429375

Option 2 ID : 264330429373

Option 3 ID : 264330429376

Option 4 ID : 264330429374

Status : Answered

Chosen Option : 2

Q.36 ध्रुवों और भूमध्य रेखा के पास क्षोभमंडल की ऊँचाई क्रमशः कितनी है?

- Ans
- 1. 16 km और 6 km
 - 2. 4 km और 16 km
 - 3. 18 km और 8 km
 - 4. 8 km और 18 km

Question ID : 264330117619

Option 1 ID : 264330462504

Option 2 ID : 264330462503

Option 3 ID : 264330462502

Option 4 ID : 264330462501

Status : Not Answered

Chosen Option : --

Q.37 _____ ने _____ में दूसरे ओलंपिक खेलों की मेज़बानी की थी?

- Ans
- 1. फ्रांस, 1900
 - 2. यूएसए, 1900
 - 3. इंग्लैंड, 1900
 - 4. जापान, 1900

Question ID : 264330110360

Option 1 ID : 264330433717

Option 2 ID : 264330433718

Option 3 ID : 264330433719

Option 4 ID : 264330433720

Status : Answered

Chosen Option : 1

Q.38 'द माउंटेन ऑफ लाइट' उपन्यास की लेखिका कौन हैं?

- Ans
- 1. मीना कंदासामी
 - 2. इंदु सुंदरेसन
 - 3. ज़रीन खान
 - 4. अनुकृति उपाध्याय

Question ID : 26433071715

Option 1 ID : 264330281285

Option 2 ID : 264330281286

Option 3 ID : 264330281287

Option 4 ID : 264330281284

Status : Not Answered

Chosen Option : --

Q.39 निम्नलिखित में से किस स्थिति में, विशेषकर प्रारंभिक गर्भावस्था के दौरान, आयोडीन और थायराइड हार्मोन की कमी के कारण गंभीर शारीरिक और मानसिक मंदता हो जाती है?

- Ans
- ✓ 1. अवटुवामनता (Cretinism)
 - ✗ 2. प्राकगर्भक्षिपक (Preeclampsia)
 - ✗ 3. उपदंश (Syphilis)
 - ✗ 4. आविषद्रव्यता (Toxoplasmosis)

Question ID : 264330113465
Option 1 ID : 264330445946
Option 2 ID : 264330445947
Option 3 ID : 264330445945
Option 4 ID : 264330445948
Status : Answered
Chosen Option : 3

Q.40 निम्नलिखित रसायनों से मेथिल क्लोराइड के रासायनिक सूत्र की पहचान कीजिए।

- Ans
- ✗ 1. C_2H_6
 - ✗ 2. CH_4
 - ✗ 3. C_2H_2
 - ✓ 4. CH_3Cl

Question ID : 264330137302
Option 1 ID : 264330537838
Option 2 ID : 264330537835
Option 3 ID : 264330537836
Option 4 ID : 264330537837
Status : Answered
Chosen Option : 4

Q.41 भारतीय राष्ट्रीय कांग्रेस के पहले वार्षिक अधिवेशन के अध्यक्ष कौन थे?

- Ans
- ✓ 1. डब्ल्यू.सी. बनर्जी (WC Banerjee)
 - ✗ 2. ए.ओ. ह्यूम (AO Hume)
 - ✗ 3. सुरेंद्र नाथ बनर्जी (Surendra Nath Banerjee)
 - ✗ 4. दादाभाई नौरोजी (Dadabhai Naoroji)

Question ID : 264330112180
Option 1 ID : 264330440807
Option 2 ID : 264330440808
Option 3 ID : 264330440805
Option 4 ID : 264330440806
Status : Answered
Chosen Option : 1

Q.42 उस तत्व की पहचान कीजिए जिसका परमाणु क्रमांक 7 है।

- Ans
- ✗ 1. कैल्शियम
 - ✗ 2. ऑक्सीजन
 - ✗ 3. क्लोरीन
 - ✓ 4. नाइट्रोजन

Question ID : 264330134864
Option 1 ID : 264330528391
Option 2 ID : 264330528392
Option 3 ID : 264330528393
Option 4 ID : 264330528394
Status : Answered
Chosen Option : 4

Q.43 एशियाई खेलों की मेजबानी करने वाला पहला देश कौन-सा था?

- Ans
- 1. चीन
 - 2. श्रीलंका
 - 3. भारत
 - 4. जापान

Question ID : 264330110328
Option 1 ID : 264330433590
Option 2 ID : 264330433592
Option 3 ID : 264330433589
Option 4 ID : 264330433591
Status : Answered
Chosen Option : 3

Q.44 शतरंज का एकमात्र ऐसा मोहरा कौन-सा है, जो L आकार में किसी भी वर्ग में जा सकता है?

- Ans
- 1. राजा
 - 2. हाथी
 - 3. वज़ीर
 - 4. घोड़ा

Question ID : 264330119288
Option 1 ID : 264330467442
Option 2 ID : 264330467440
Option 3 ID : 264330467439
Option 4 ID : 264330467441
Status : Not Answered
Chosen Option : --

Q.45 द्रोणाचार्य पुरस्कार किस वर्ष शुरू किया गया था?

- Ans
- 1. 1980 में
 - 2. 1961 में
 - 3. 1990 में
 - 4. 1985 में

Question ID : 264330110366
Option 1 ID : 264330433744
Option 2 ID : 264330433743
Option 3 ID : 264330433742
Option 4 ID : 264330433741
Status : Answered
Chosen Option : 3

Q.46 निम्नलिखित में से किसने 641 ई. में चीनी दरबार में अपना दूत भेजा था?

- Ans
- 1. हर्षवर्धन
 - 2. नरसिंहवर्मन द्वितीय
 - 3. पुलकेशिन प्रथम
 - 4. नरसिंहवर्मन प्रथम

Question ID : 264330112144
Option 1 ID : 264330440661
Option 2 ID : 264330440662
Option 3 ID : 264330440664
Option 4 ID : 264330440663
Status : Answered
Chosen Option : 4

Q.47 निम्नलिखित में से किस सुल्तान ने सामंतों की शक्ति को कमजोर करने के लिए विनियमनों की एक शृंखला तैयार की थी?

- Ans
- 1. इल्तुतमिश
 - 2. बलबन
 - 3. अलाउद्दीन खिलजी
 - 4. मुहम्मद बिन तुगलक

Question ID : 264330109007

Option 1 ID : 264330428305

Option 2 ID : 264330428306

Option 3 ID : 264330428308

Option 4 ID : 264330428307

Status : Answered

Chosen Option : 3

Q.48 रावी, चिनाब और झेलम किस नदी की सहायक नदियां हैं?

- Ans
- 1. कावेरी
 - 2. कृष्णा
 - 3. सिंधु
 - 4. तुंगभद्रा

Question ID : 264330169996

Option 1 ID : 264330666660

Option 2 ID : 264330666662

Option 3 ID : 264330666661

Option 4 ID : 264330666659

Status : Answered

Chosen Option : 3

Q.49 मुद्रा आपूर्ति के संदर्भ में सही कथनों की पहचान कीजिए।

- (i) मुद्रा आपूर्ति, किसी विशेष समय में जनता द्वारा रखे गए धन की कुल मात्रा को संदर्भित करती है।
- (ii) मुद्रा आपूर्ति एक प्रवाह अवधारणा है।
- (iii) M1, मुद्रा आपूर्ति का सबसे तरल उपाय है।

- Ans
- 1. केवल (ii)
 - 2. केवल (i)
 - 3. केवल (i) और (iii)
 - 4. केवल (ii) और (iii)

Question ID : 264330109092

Option 1 ID : 264330428647

Option 2 ID : 264330428645

Option 3 ID : 264330428646

Option 4 ID : 264330428648

Status : Not Answered

Chosen Option : --

Q.50 भारत की जनगणना (2011) के अनुसार, राज्यों के किस समूह में ग्रामीण जनसंख्या का प्रतिशत बहुत अधिक है?

- Ans
- 1. राजस्थान और गुजरात
 - 2. गोवा और ओडिशा
 - 3. बिहार और सिक्किम
 - 4. पंजाब और हरियाणा

Question ID : 264330119922

Option 1 ID : 264330469965

Option 2 ID : 264330469966

Option 3 ID : 264330469963

Option 4 ID : 264330469964

Status : Answered

Chosen Option : 4

Section : English Language and Comprehension

Q.1 Select the option that changes the voice of the following sentence.

The newlywed couple has bought a new house in Delhi.

- Ans
- 1. A new house in Delhi was being bought by the newlywed couple.
 - 2. A new house in Delhi has been bought by the newlywed couple.
 - 3. A new house in Delhi was bought by the newlywed couple.
 - 4. A new house in Delhi have been bought by the newlywed couple.

Question ID : 264330164606

Option 1 ID : 264330645610

Option 2 ID : 264330645609

Option 3 ID : 264330645608

Option 4 ID : 264330645607

Status : Answered

Chosen Option : 2

Q.2 The following sentence has been split into four segments. Identify the segment that contains a grammatical error.

Arpit and Barkha went /for Zumba / classes these / days.

- Ans
- 1. days
 - 2. Arpit and Barkha went
 - 3. classes these
 - 4. for Zumba

Question ID : 264330139392

Option 1 ID : 264330546018

Option 2 ID : 264330546015

Option 3 ID : 264330546017

Option 4 ID : 264330546016

Status : Answered

Chosen Option : 4

Q.3 Select the most appropriate option that can substitute the underlined segment in the given sentence.

The thief who had been accused for the bank theft was later acquitted because of lack of evidence.

- Ans
- 1. accused in the bank theft was
 - 2. accusing of the bank theft was
 - 3. accused of the bank theft was
 - 4. accusing for the bank theft was

Question ID : 264330100998
Option 1 ID : 264330396537
Option 2 ID : 264330396538
Option 3 ID : 264330396539
Option 4 ID : 264330396540
Status : Answered
Chosen Option : 3

Q.4 Select the most appropriate synonym of the word given in the brackets to fill in the blank.

Students should be _____ (sincere) in their studies.

- Ans
- 1. factual
 - 2. serious
 - 3. legit
 - 4. literal

Question ID : 264330165024
Option 1 ID : 264330647223
Option 2 ID : 264330647226
Option 3 ID : 264330647225
Option 4 ID : 264330647224
Status : Answered
Chosen Option : 3

Q.5 Select the most appropriate option that can substitute the underlined segment in the given sentence.

The list of wedding guests are kept there, in the table.

- Ans
- 1. wedding guests is kept there, on
 - 2. wedding guests is kept there in
 - 3. wedding guests are kept there on
 - 4. wedding guests kept there on

Question ID : 264330117266
Option 1 ID : 264330461123
Option 2 ID : 264330461122
Option 3 ID : 264330461121
Option 4 ID : 264330461124
Status : Not Answered
Chosen Option : --

Q.6 Select the option that expresses the following sentence in indirect speech.

The teacher said, "The university will be closed tomorrow."

- Ans 1. The teacher said that the university would be closed the day after.
 2. The teacher said that the university will be closing tomorrow.
 3. The teacher said that the university would be closed tomorrow.
 4. The teacher asked that the university will be closed the day after.

Question ID : 264330163353
Option 1 ID : 264330640705
Option 2 ID : 264330640706
Option 3 ID : 264330640703
Option 4 ID : 264330640704
Status : Answered
Chosen Option : 3

Q.7 Select the correct option to substitute the underlined segment in the given sentence. If no substitution is required, select 'No substitution'.

Shreya prefers ice-cream than chocolates.

- Ans 1. to
 2. over
 3. from
 4. No substitution

Question ID : 26433090825
Option 1 ID : 264330356722
Option 2 ID : 264330356721
Option 3 ID : 264330356723
Option 4 ID : 264330356724
Status : Answered
Chosen Option : 1

Q.8 Select the most appropriate synonym of the bracketed word in the following sentence to fill in the blank.

We are expecting a _____ narrative from the writer about his childhood.
(intelligible)

- Ans 1. lucid
 2. written
 3. historical
 4. disorderly

Question ID : 264330163275
Option 1 ID : 264330640412
Option 2 ID : 264330640411
Option 3 ID : 264330640413
Option 4 ID : 264330640414
Status : Not Answered
Chosen Option : --

Q.9 Select the option that expresses the given sentence in active voice.

The car is being driven by a young boy.

- Ans 1. A young boy is driving the car.
 2. A young boy has driven the car.
 3. A young boy was driving the car.
 4. A young boy drives the car.

Question ID : 264330164185

Option 1 ID : 264330643988

Option 2 ID : 264330643989

Option 3 ID : 264330643987

Option 4 ID : 264330643990

Status : Answered

Chosen Option : 1

Q.10 Sentences of a paragraph are given below. While the first and the last sentences (S1 and S6) are in the correct order, the sentences in between are jumbled up. Arrange the sentences in the correct order to form a meaningful and coherent paragraph.

S1. Ferdinand Verbiest designed the first working steam-powered vehicle in China in 1672.

A. Locomotive acts was introduced in 1865.

B. It was around 65 cm long for the Chinese emperor.

C. Nicolas Joseph Cugnot has the credit for developing the first automobile in 1769.

D. Richard Trevithick demonstrated the first steam-powered road vehicle.

S6. Pyreolophore is the name of the world's first internal combustion engine.

- Ans 1. DABC
 2. CDAB
 3. BCDA
 4. ADBC

Question ID : 264330117276

Option 1 ID : 264330461164

Option 2 ID : 264330461163

Option 3 ID : 264330461162

Option 4 ID : 264330461161

Status : Answered

Chosen Option : 4

Q.11 Select the option that expresses the given sentence in direct speech.
Tara asked whether we would come for the company meeting.

- Ans 1. Tara said, "Will you came for the company meeting?"
 2. Tara said, "Will you come for the company meeting?"
 3. Tara say, "Will you come for the company meeting?"
 4. Tara says, "Would you comes for the company meeting?"

Question ID : 264330135987

Option 1 ID : 264330532793

Option 2 ID : 264330532791

Option 3 ID : 264330532792

Option 4 ID : 264330532794

Status : Answered

Chosen Option : 2

Q.12 Select the most appropriate idiom for the given situation focusing on the underlined segment.

You are wasting time by arguing just for the sake of argument and that too just the opposite of what we confirm.

- Ans
- 1. Beat around the bush
 - 2. The devil is in the details
 - 3. Throw caution to the wind
 - 4. Play devil's advocate

Question ID : 264330163408
Option 1 ID : 264330640911
Option 2 ID : 264330640912
Option 3 ID : 264330640914
Option 4 ID : 264330640913
Status : Not Answered
Chosen Option : --

Q.13 Select the most appropriate option to substitute the underlined segment in the given sentence.

Newton found out that the force of gravitation makes the apples fall.

- Ans
- 1. Newton invented that
 - 2. Newton discovered that
 - 3. Newton registered that
 - 4. Newton popularised that

Question ID : 26433093477
Option 1 ID : 264330367133
Option 2 ID : 264330367135
Option 3 ID : 264330367134
Option 4 ID : 264330367136
Status : Answered
Chosen Option : 1

Q.14 Select the most appropriate ANTONYM of the given word.
Modest

- Ans
- 1. Unpretentious
 - 2. Arrogant
 - 3. Generous
 - 4. Humble

Question ID : 264330168136
Option 1 ID : 264330659422
Option 2 ID : 264330659421
Option 3 ID : 264330659420
Option 4 ID : 264330659419
Status : Answered
Chosen Option : 4

Q.15 Select the option that expresses the given sentence in active voice.

The data was not analysed by the researchers carefully.

- Ans
- 1. The researchers do not analyse the data carefully.
 - 2. The researchers did not analyse the data carefully.
 - 3. The researchers had not analysed the data carefully.
 - 4. The researchers have not analysed the data carefully.

Question ID : 264330164187
Option 1 ID : 264330643998
Option 2 ID : 264330643997
Option 3 ID : 264330643996
Option 4 ID : 264330643995
Status : Answered
Chosen Option : 2

Q.16 Select the option that expresses the given sentence in reported speech.
He said, "I have forgotten the combination of my safe".

- Ans
- 1. He said that he had been forgotten the combination of his safe.
 - 2. He said that he has been forgotten the combination of his safe.
 - 3. He said that he has forgotten the combination of his safe.
 - 4. He said that he had forgotten the combination of his safe.

Question ID : 264330137435
Option 1 ID : 264330538370
Option 2 ID : 264330538369
Option 3 ID : 264330538367
Option 4 ID : 264330538368
Status : Answered
Chosen Option : 4

Q.17 The following sentence has been divided into parts. One of them may contain an error.
Select the part that contains the error from the given options.
He is famous / about his research / in the field of / astrophysics.

- Ans
- 1. about his research
 - 2. He is famous
 - 3. astrophysics.
 - 4. in the field of

Question ID : 264330164241
Option 1 ID : 264330644196
Option 2 ID : 264330644195
Option 3 ID : 264330644198
Option 4 ID : 264330644197
Status : Answered
Chosen Option : 1

Q.18 Select the option that expresses the following sentence in active voice.
The winner of the competition was announced by them.

- Ans
- 1. They announced a winner in the competition.
 - 2. They have announced the competition winner.
 - 3. Announcement of the winner of the competition by them.
 - 4. They announced the winner of the competition.

Question ID : 264330168111
Option 1 ID : 264330659326
Option 2 ID : 264330659324
Option 3 ID : 264330659323
Option 4 ID : 264330659325
Status : Answered
Chosen Option : 4

Q.19 Select the option that expresses the given sentence in indirect speech.
He said, "I have never seen anything like that before".

- Ans
- 1. He said that he was never seen anything like that before.
 - 2. He said that he didn't see anything like that before.
 - 3. He said that he has never seen anything like that before.
 - 4. He said that he had never seen anything like that before.

Question ID : 264330139228
Option 1 ID : 264330545449
Option 2 ID : 264330545448
Option 3 ID : 264330545447
Option 4 ID : 264330545450
Status : Answered
Chosen Option : 4

Q.20 Select the most appropriate option that can substitute the underlined segment in the given sentence. If there is no need to substitute it, select 'No substitution'.
Harsha is the tallest than all the other boys in his colony.

- Ans
- 1. no substitution
 - 2. of all the boys
 - 3. than some other boys
 - 4. than any boy

Question ID : 264330132828
Option 1 ID : 264330520402
Option 2 ID : 264330520399
Option 3 ID : 264330520400
Option 4 ID : 264330520401
Status : Answered
Chosen Option : 4

Q.21 Select the most appropriate option that can substitute the underlined segment in the given sentence.

He looked at me happily when I interrupted him.

- Ans
- 1. angrily
 - 2. suddenly
 - 3. surprisingly
 - 4. hardly

Question ID : 264330120556

Option 1 ID : 264330472467

Option 2 ID : 264330472469

Option 3 ID : 264330472470

Option 4 ID : 264330472468

Status : Answered

Chosen Option : 3

Q.22 Choose the most suitable idiom for the given situation.

Your friend has already told me everything about your secret surprise that you were planning for the last two weeks.

- Ans
- 1. My lips are sealed
 - 2. To keep something under your hat
 - 3. To spill the beans
 - 4. Behind closed doors

Question ID : 264330135903

Option 1 ID : 264330532468

Option 2 ID : 264330532467

Option 3 ID : 264330532469

Option 4 ID : 264330532470

Status : Answered

Chosen Option : 3

Q.23 Select the most appropriate synonym of the given word.

Anguish

- Ans
- 1. Pain
 - 2. Restrain
 - 3. Gain
 - 4. Obtain

Question ID : 264330168265

Option 1 ID : 264330659928

Option 2 ID : 264330659927

Option 3 ID : 264330659929

Option 4 ID : 264330659930

Status : Not Answered

Chosen Option : --

Q.24 Select the most appropriate meaning of the given idiom.
Read between the lines.

- Ans
- 1. Look for implied meaning
 - 2. Read text in an unknown language
 - 3. Read a poem
 - 4. Misunderstand a message

Question ID : 264330168284
Option 1 ID : 264330660003
Option 2 ID : 264330660006
Option 3 ID : 264330660005
Option 4 ID : 264330660004
Status : Answered
Chosen Option : 1

Q.25 Select the most appropriate option to fill in the blank.
I _____ to the hope that he's still alive.

- Ans
- 1. take
 - 2. hold
 - 3. cling
 - 4. grab

Question ID : 264330168336
Option 1 ID : 264330660209
Option 2 ID : 264330660208
Option 3 ID : 264330660210
Option 4 ID : 264330660207
Status : Answered
Chosen Option : 4

Q.26 Select the most appropriate ANTONYM of the given word.
Comprehensive

- Ans
- 1. Complete
 - 2. Exhaustive
 - 3. Through
 - 4. Superficial

Question ID : 264330168139
Option 1 ID : 264330659433
Option 2 ID : 264330659432
Option 3 ID : 264330659434
Option 4 ID : 264330659431
Status : Answered
Chosen Option : 2

Q.27 Select the most appropriate option that can substitute the underlined segment in the given sentence.

I asked to my brother to get my air tickets booked.

- Ans
- 1. for my brother to get
 - 2. for my brother get
 - 3. my brother to get
 - 4. to my brother get

Question ID : 264330117258

Option 1 ID : 264330461091

Option 2 ID : 264330461092

Option 3 ID : 264330461090

Option 4 ID : 264330461089

Status : Answered

Chosen Option : 4

Q.28 Sentences of a paragraph are given below in jumbled order. Arrange the sentences in the correct order to form a meaningful and coherent paragraph.

A.The rupee's recent decline is primarily owing to high crude oil prices, a strong dollar abroad and international capital outflows.

B.The value of the Indian rupee in relation to the US dollar is determined by supply and demand.

C.If a country imports more than it exports, the demand for the dollar exceeds the supply, and the domestic currency, such as the Indian rupee, depreciates against the dollar.

D.When the US dollar is in strong demand, the Indian rupee falls in value, and vice versa.

- Ans
- 1. CDBA
 - 2. CABD
 - 3. BDCA
 - 4. BADC

Question ID : 26433097523

Option 1 ID : 264330382765

Option 2 ID : 264330382767

Option 3 ID : 264330382768

Option 4 ID : 264330382766

Status : Not Answered

Chosen Option : --

Q.29 Select the option that expresses the given sentence in passive voice.
Who taught you English?

- Ans
- 1. English taught you who?
 - 2. By whom was English taught to you?
 - 3. Who was your English teacher?
 - 4. By whom was you taught English?

Question ID : 264330134138

Option 1 ID : 264330525575

Option 2 ID : 264330525578

Option 3 ID : 264330525576

Option 4 ID : 264330525577

Status : Answered

Chosen Option : 4

Q.30 Select the most appropriate option to fill in the blank.

Although he is a calm person most of the time, he occasionally loses his _____.

- Ans
- 1. temper
 - 2. anger
 - 3. anxiety
 - 4. calm

Question ID : 26433098903
Option 1 ID : 264330388268
Option 2 ID : 264330388265
Option 3 ID : 264330388266
Option 4 ID : 264330388267
Status : Answered
Chosen Option : 3

Q.31 Select the word that fills in the blank correctly and completes the following sentence meaningfully.

In order to attract new readers and increase sales, the publishers of Stephen Hawking's books have asked a few scientists to rewrite some of his books and _____ them _____ so non-science readers can understand them.

- Ans
- 1. dumb, down
 - 2. push, down
 - 3. beat, in
 - 4. dig, in

Question ID : 264330139101
Option 1 ID : 264330545013
Option 2 ID : 264330545012
Option 3 ID : 264330545014
Option 4 ID : 264330545011
Status : Not Answered
Chosen Option : --

Q.32 Select the most appropriate option that can substitute the underlined segment in the given sentence.

If it will rain tomorrow, I will be on leave.

- Ans
- 1. it will be raining tomorrow
 - 2. it doesn't rain tomorrow
 - 3. it rains tomorrow
 - 4. it will not rain tomorrow

Question ID : 264330117263
Option 1 ID : 264330461112
Option 2 ID : 264330461110
Option 3 ID : 264330461109
Option 4 ID : 264330461111
Status : Answered
Chosen Option : 3

Q.33 The following sentence has been split into four segments. Identify the segment that contains a grammatical error.
She can't come for lunch / with you. / She'll do some / training in the gym.

- Ans 1. with you
 2. She can't come for lunch
 3. She'll do some
 4. training in the gym

Question ID : 264330120566
Option 1 ID : 264330472509
Option 2 ID : 264330472507
Option 3 ID : 264330472510
Option 4 ID : 264330472508
Status : Answered
Chosen Option : 3

Q.34 Select the option that expresses the given sentence in active voice.
The cake had been baked by Sarah.

- Ans 1. Sarah will bake the cake.
 2. Sarah had baked the cake.
 3. Sarah has been baking the cake.
 4. Sarah bakes the cake.

Question ID : 264330164368
Option 1 ID : 264330644686
Option 2 ID : 264330644685
Option 3 ID : 264330644683
Option 4 ID : 264330644684
Status : Answered
Chosen Option : 2

Q.35 Select the most appropriate option that substitute the underlined segment in the given sentence. If there is no need to substitute it, select 'No substitution required'.

No woman would be pleased if you said that she did not know the difference in good and bad dressing.

- Ans 1. No substitution required
 2. among good and bad
 3. into good and bad
 4. between good and bad

Question ID : 264330101276
Option 1 ID : 264330397652
Option 2 ID : 264330397651
Option 3 ID : 264330397649
Option 4 ID : 264330397650
Status : Answered
Chosen Option : 4

Q.36 Select the most appropriate synonym of the given word.
Unique

- Ans
- 1. Wavy
 - 2. Kind
 - 3. Distinctive
 - 4. Common

Question ID : 264330164166
Option 1 ID : 264330643917
Option 2 ID : 264330643918
Option 3 ID : 264330643915
Option 4 ID : 264330643916
Status : Answered
Chosen Option : 1

Q.37 Select the most appropriate option to fill in the blank.

MS Dhoni was _____ with a natural talent for cricket.

- Ans
- 1. endowed
 - 2. found
 - 3. owned
 - 4. entrusted

Question ID : 26433098894
Option 1 ID : 264330388229
Option 2 ID : 264330388230
Option 3 ID : 264330388231
Option 4 ID : 264330388232
Status : Answered
Chosen Option : 1

Q.38 Select the option that expresses the given sentence in reported speech.

“Let there be fresh elections,” the committee proposed.

- Ans
- 1. The committee proposed that there should be fresh elections.
 - 2. The committee suggested to there be conduct fresh elections.
 - 3. The committee was for fresh elections.
 - 4. The committee would propose that the elections should be fresh.

Question ID : 264330164600
Option 1 ID : 264330645584
Option 2 ID : 264330645586
Option 3 ID : 264330645585
Option 4 ID : 264330645583
Status : Answered
Chosen Option : 1

Q.39 Select the option that expresses the given sentence in passive voice.
Why has Utpal injured my pet dogs?

- Ans
- 1. Why did been my pet dogs injured by Utpal?
 - 2. Why has my pet dogs been injured by Utpal?
 - 3. Why have my pet dogs been injured by Utpal?
 - 4. Why had my pet dogs been injured by Utpal?

Question ID : 264330164622
Option 1 ID : 264330645670
Option 2 ID : 264330645668
Option 3 ID : 264330645667
Option 4 ID : 264330645669
Status : Answered
Chosen Option : 2

Q.40 Select the option that expresses the given sentence in indirect speech.
Riya said to me, "I am happy to see you."

- Ans
- 1. Riya told me that she is happy to see me.
 - 2. Riya told me that she was happy to see me.
 - 3. Riya told me that she is happy to see you.
 - 4. Riya told me that she was happy to see you.

Question ID : 264330164292
Option 1 ID : 264330644386
Option 2 ID : 264330644385
Option 3 ID : 264330644384
Option 4 ID : 264330644383
Status : Answered
Chosen Option : 2

Q.41 Select the most appropriate option to fill in the blank.

There is a special heritage for all of us in India, not an exclusive one, for none _____ exclusive when it comes to shared heritage.

- Ans
- 1. beckons
 - 2. beckoning
 - 3. beckoned
 - 4. have beckoned

Question ID : 26433092115
Option 1 ID : 264330361782
Option 2 ID : 264330361781
Option 3 ID : 264330361783
Option 4 ID : 264330361784
Status : Not Answered
Chosen Option : --

Q.42 In the following questions a statement has been given with highlighted text. Select the options that can replace the text with correct idiom or phrase.
He is too afraid of heights after the bungee jumping experience.

- Ans
- ✓ 1. Once bitten twice shy
 - ✗ 2. Pour out one's heart
 - ✗ 3. Break the bank
 - ✗ 4. Light at the end of tunnel

Question ID : 264330120758
Option 1 ID : 264330473248
Option 2 ID : 264330473250
Option 3 ID : 264330473247
Option 4 ID : 264330473249
Status : Not Answered
Chosen Option : --

Q.43 The following sentence has been split into four segments. Identify the segment that contains a grammatical error.

Sheetal always became nervous / whenever she gets instructions / from her Physics / teacher at the lab.

- Ans
- ✓ 1. Sheetal always became nervous
 - ✗ 2. teacher at the lab
 - ✗ 3. whenever she gets instructions
 - ✗ 4. from her Physics

Question ID : 26433094750
Option 1 ID : 264330371833
Option 2 ID : 264330371836
Option 3 ID : 264330371834
Option 4 ID : 264330371835
Status : Answered
Chosen Option : 1

Q.44 Select the option that expresses the given sentence in reported speech.
My friend said, "I am going to travel to Europe next month".

- Ans
- ✗ 1. My friend had said that he would travel to Europe the following month.
 - ✗ 2. My friend said that he will travel to Europe next month.
 - ✓ 3. My friend said that he was going to travel to Europe the following month.
 - ✗ 4. My friend says that he is going to travel to Europe next month.

Question ID : 264330137492
Option 1 ID : 264330538588
Option 2 ID : 264330538590
Option 3 ID : 264330538589
Option 4 ID : 264330538587
Status : Answered
Chosen Option : 3

Q.45 Select the most appropriate synonym of the given word.
Acquisitive

- Ans
- 1. Critical
 - 2. Apathetic
 - 3. Aspiring
 - 4. Eager

Question ID : 264330165244
Option 1 ID : 264330648076
Option 2 ID : 264330648077
Option 3 ID : 264330648075
Option 4 ID : 264330648078
Status : Not Answered
Chosen Option : --

Q.46 Select the most appropriate meaning of the underlined idiom.
He escaped the train disaster by the skin of his teeth.

- Ans
- 1. Inconsistency in statements
 - 2. By a huge margin
 - 3. Entrust someone with everything
 - 4. By a very narrow margin

Question ID : 264330164279
Option 1 ID : 264330644340
Option 2 ID : 264330644339
Option 3 ID : 264330644342
Option 4 ID : 264330644341
Status : Answered
Chosen Option : 3

Q.47 Select the option that expresses the given sentence in reported speech.
He asked whether he should lock the car or leave it.

- Ans
- 1. He said, "Shall I lock the car or leave it unlocked?"
 - 2. He said, "Shall he locked the car or leave it unlocked?"
 - 3. He said, "Shall I locked the car or leave it unlocked?"
 - 4. He said, "Shall he locks the car or leave it unlocked?"

Question ID : 264330137438
Option 1 ID : 264330538381
Option 2 ID : 264330538382
Option 3 ID : 264330538380
Option 4 ID : 264330538379
Status : Answered
Chosen Option : 3

Q.48 The abstract noun form of 'act' is 'action'. Similarly, the abstract noun form of 'wide' will be:

- Ans
- 1. width
 - 2. wideness
 - 3. wisdom
 - 4. widespread

Question ID : 264330120525
Option 1 ID : 264330472353
Option 2 ID : 264330472352
Option 3 ID : 264330472351
Option 4 ID : 264330472354
Status : Not Answered
Chosen Option : --

Q.49 Select the most appropriate option that can substitute the underlined segment in the given sentence.

She is strictly advised to be on bed for three weeks lest she would fall sick again.

- Ans
- 1. lest she can fall sick again
 - 2. lest she should fall sick again
 - 3. lest she shall fall sick again
 - 4. lest she will fall sick again

Question ID : 264330117271
Option 1 ID : 264330461141
Option 2 ID : 264330461143
Option 3 ID : 264330461142
Option 4 ID : 264330461144
Status : Answered
Chosen Option : 2

Q.50 Select the most appropriate option that can substitute the underlined segment in the given sentence.

The politician, along with the newsmen, are expected shortly.

- Ans
- 1. is expected shortly
 - 2. has expected shortly
 - 3. am expected shortly
 - 4. were expected shortly

Question ID : 264330117114
Option 1 ID : 264330460526
Option 2 ID : 264330460528
Option 3 ID : 264330460525
Option 4 ID : 264330460527
Status : Answered
Chosen Option : 2

Q.51 Select the most appropriate ANTONYM of the given word.
Generous

- Ans
- 1. Altruist
 - 2. Charitable
 - 3. Kind
 - 4. Greedy

Question ID : 264330168134
Option 1 ID : 264330659412
Option 2 ID : 264330659411
Option 3 ID : 264330659413
Option 4 ID : 264330659414
Status : Not Answered
Chosen Option : --

Q.52 Select the most appropriate option that can substitute the underlined segment in the given sentence. If there is no need to substitute it, select 'No substitution.'
In the jungle, they encountered a school of lions .

- Ans
- 1. pride of lions
 - 2. No substitution
 - 3. sloth of lions
 - 4. pack of lions

Question ID : 264330120519
Option 1 ID : 264330472328
Option 2 ID : 264330472330
Option 3 ID : 264330472329
Option 4 ID : 264330472327
Status : Answered
Chosen Option : 1

Q.53 Select the option that expresses the given sentence in passive voice.
Open the door for your brother.

- Ans
- 1. Let the door been opened for your brother.
 - 2. Let the door opened for your brother.
 - 3. Let the door be open for your brother.
 - 4. Let the door be opened for your brother.

Question ID : 264330137231
Option 1 ID : 264330537557
Option 2 ID : 264330537558
Option 3 ID : 264330537556
Option 4 ID : 264330537555
Status : Answered
Chosen Option : 4

Q.54 Select the option that expresses the given sentence in reported speech.
He said to me, "How are you now?"

- Ans
- 1. He asked me that how I was now.
 - 2. He asked me If I was well then.
 - 3. He asked me how was I then.
 - 4. He asked me how I was then.

Question ID : 264330135874
Option 1 ID : 264330532362
Option 2 ID : 264330532359
Option 3 ID : 264330532360
Option 4 ID : 264330532361
Status : Answered
Chosen Option : 4

Q.55 Select the most appropriate ANTONYM of the underlined word in the following sentence.

The performance he gave was truly marvellous.

- Ans
- 1. Terrible
 - 2. Mesmerising
 - 3. Long
 - 4. Interesting

Question ID : 264330164309
Option 1 ID : 264330644454
Option 2 ID : 264330644453
Option 3 ID : 264330644452
Option 4 ID : 264330644451
Status : Answered
Chosen Option : 1

Q.56 Select the most appropriate synonym of the underlined word in the following sentence.

The disgruntled passengers were discussing the matter with the authorities.

- Ans
- 1. Tortured
 - 2. Annoyed
 - 3. Capricious
 - 4. Contented

Question ID : 264330168125
Option 1 ID : 264330659379
Option 2 ID : 264330659382
Option 3 ID : 264330659380
Option 4 ID : 264330659381
Status : Answered
Chosen Option : 2

Q.57 The following sentence has been split into four segments. Identify the segment that contains a grammatical error.
 They missed their train / because they were waiting / on wrong platform. / They were on platform 3 instead of platform 8.

- Ans**
- 1. Because they were waiting
 - 2. On wrong platform
 - 3. They missed their train
 - 4. They were on platform 3 instead of platform 8

Question ID : 264330122585
 Option 1 ID : 264330480464
 Option 2 ID : 264330480465
 Option 3 ID : 264330480463
 Option 4 ID : 264330480466
 Status : Answered
 Chosen Option : 3

Q.58 Select the option that expresses the given sentence in passive voice.
 Priyanka edits the school magazine.

- Ans**
- 1. The school magazine were edited by Priyanka.
 - 2. The school magazine is edited by Priyanka.
 - 3. The school magazine is edit by Priyanka.
 - 4. The school magazine was edited by Priyanka.

Question ID : 264330137230
 Option 1 ID : 264330537554
 Option 2 ID : 264330537553
 Option 3 ID : 264330537552
 Option 4 ID : 264330537551
 Status : Answered
 Chosen Option : 2

Q.59 The following sentence has been divided into segments. One of them may contain an error. Select the segment that contains the error from the given options. If you don't find any error, mark 'No error' as your answer.

Two people were / fighting to each other / for no reason.

- Ans**
- 1. Two people were
 - 2. for no reason.
 - 3. fighting to each other
 - 4. No Error

Question ID : 26433096144
 Option 1 ID : 264330377345
 Option 2 ID : 264330377347
 Option 3 ID : 264330377346
 Option 4 ID : 264330377348
 Status : Answered
 Chosen Option : 3

Q.60 Parts of the following sentence have been given as options. Select the option that contains an error.

He is enjoying the programme very much. He want to stay till the end.

- Ans
- 1. He want to
 - 2. He is enjoying
 - 3. the program very much
 - 4. stay till the end

Question ID : 264330100236

Option 1 ID : 264330393519

Option 2 ID : 264330393517

Option 3 ID : 264330393518

Option 4 ID : 264330393520

Status : Answered

Chosen Option : 3

Q.61 Select the most appropriate idiom for the given phrase.

Completely mistaken

- Ans
- 1. Though thick and thin
 - 2. Hunger pangs
 - 3. Bite the bullet
 - 4. All wet

Question ID : 264330157061

Option 1 ID : 264330615617

Option 2 ID : 264330615615

Option 3 ID : 264330615618

Option 4 ID : 264330615616

Status : Answered

Chosen Option : 2

Q.62 The following sentence has been split into four segments. Identify the segment that contains a grammatical error.

We have to go / under the books if / we want to pass / the board exams this year.

- Ans
- 1. the board exams this year
 - 2. we want to pass
 - 3. We have to go
 - 4. under the books if

Question ID : 264330139099

Option 1 ID : 264330545006

Option 2 ID : 264330545005

Option 3 ID : 264330545003

Option 4 ID : 264330545004

Status : Answered

Chosen Option : 3

Q.63 The following sentence has been split into four segments. Identify the segment that contains a grammatical error.

In October, / they will have lived / in San Francisco /for five years.

- Ans
- 1. for five years
 - 2. in San Francisco
 - 3. In October
 - 4. they will have lived

Question ID : 264330102133
Option 1 ID : 264330400998
Option 2 ID : 264330400997
Option 3 ID : 264330401000
Option 4 ID : 264330400999
Status : Answered
Chosen Option : 4

Q.64 Select the most appropriate option that can substitute the underlined segment in the given sentence.

The rural households in many of the developing countries don't have fully fictional tap water connections.

- Ans
- 1. don't have fully revisional tap water
 - 2. don't have fully functional tap water
 - 3. don't have fully devotional tap water
 - 4. don't have fully erosional tap water

Question ID : 264330100994
Option 1 ID : 264330396522
Option 2 ID : 264330396521
Option 3 ID : 264330396524
Option 4 ID : 264330396523
Status : Not Answered
Chosen Option : --

Q.65 Select the most appropriate ANTONYM of the underlined word.
When William gets angry, he starts to act like an imbecile.

- Ans
- 1. Pleasing
 - 2. Fierce
 - 3. Intelligent
 - 4. Cheerful

Question ID : 264330140492
Option 1 ID : 264330550347
Option 2 ID : 264330550348
Option 3 ID : 264330550349
Option 4 ID : 264330550350
Status : Not Answered
Chosen Option : --

Comprehension:

In the following passage, some words have been deleted. Read the passage carefully and select the most appropriate option to fill in each blank.

The French (1) _____ was a period of great social and political upheaval in France that lasted from 1789 to 1799. It (2) _____ with the storming of the Bastille, a symbol of royal tyranny, and culminated in the rise of Napoleon Bonaparte as the dominant figure in French politics. The Revolution brought about sweeping changes to French society, including the (3) _____ of the monarchy, the establishment of a democratic republic, and the (4) _____ of many feudal privileges. Despite its many achievements, however, the Revolution was also characterised by violence, terror, and political (5) _____.

SubQuestion No : 66**Q.66 Select the most appropriate option to fill in blank 1.**

- Ans 1. Revolution
 2. Uprising
 3. Mutiny
 4. Recuperation

Question ID : 264330165109

Option 1 ID : 264330647559

Option 2 ID : 264330647561

Option 3 ID : 264330647562

Option 4 ID : 264330647560

Status : Answered

Chosen Option : 1

Comprehension:

In the following passage, some words have been deleted. Read the passage carefully and select the most appropriate option to fill in each blank.

The French (1) _____ was a period of great social and political upheaval in France that lasted from 1789 to 1799. It (2) _____ with the storming of the Bastille, a symbol of royal tyranny, and culminated in the rise of Napoleon Bonaparte as the dominant figure in French politics. The Revolution brought about sweeping changes to French society, including the (3) _____ of the monarchy, the establishment of a democratic republic, and the (4) _____ of many feudal privileges. Despite its many achievements, however, the Revolution was also characterised by violence, terror, and political (5) _____.

SubQuestion No : 67**Q.67 Select the most appropriate option to fill in blank 2.**

- Ans 1. intervened
 2. concluded
 3. hesitated
 4. commenced

Question ID : 264330165110

Option 1 ID : 264330647564

Option 2 ID : 264330647563

Option 3 ID : 264330647565

Option 4 ID : 264330647566

Status : Not Answered

Chosen Option : --

Comprehension:

In the following passage, some words have been deleted. Read the passage carefully and select the most appropriate option to fill in each blank.

The French (1) _____ was a period of great social and political upheaval in France that lasted from 1789 to 1799. It (2) _____ with the storming of the Bastille, a symbol of royal tyranny, and culminated in the rise of Napoleon Bonaparte as the dominant figure in French politics. The Revolution brought about sweeping changes to French society, including the (3) _____ of the monarchy, the establishment of a democratic republic, and the (4) _____ of many feudal privileges. Despite its many achievements, however, the Revolution was also characterised by violence, terror, and political (5) _____.

SubQuestion No : 68

Q.68 Select the most appropriate option to fill in blank 3.

- Ans 1. restoration
 2. abolition
 3. continuation
 4. preservation

Question ID : 264330165111
Option 1 ID : 264330647567
Option 2 ID : 264330647569
Option 3 ID : 264330647568
Option 4 ID : 264330647570
Status : Not Answered
Chosen Option : --

Comprehension:

In the following passage, some words have been deleted. Read the passage carefully and select the most appropriate option to fill in each blank.

The French (1) _____ was a period of great social and political upheaval in France that lasted from 1789 to 1799. It (2) _____ with the storming of the Bastille, a symbol of royal tyranny, and culminated in the rise of Napoleon Bonaparte as the dominant figure in French politics. The Revolution brought about sweeping changes to French society, including the (3) _____ of the monarchy, the establishment of a democratic republic, and the (4) _____ of many feudal privileges. Despite its many achievements, however, the Revolution was also characterised by violence, terror, and political (5) _____.

SubQuestion No : 69

Q.69 Select the most appropriate option to fill in blank 4.

- Ans 1. maintenance
 2. exaggeration
 3. amplification
 4. elimination

Question ID : 264330165112
Option 1 ID : 264330647571
Option 2 ID : 264330647574
Option 3 ID : 264330647573
Option 4 ID : 264330647572
Status : Not Answered
Chosen Option : --

Comprehension:

In the following passage, some words have been deleted. Read the passage carefully and select the most appropriate option to fill in each blank.

The French (1)_____ was a period of great social and political upheaval in France that lasted from 1789 to 1799. It (2)_____ with the storming of the Bastille, a symbol of royal tyranny, and culminated in the rise of Napoleon Bonaparte as the dominant figure in French politics. The Revolution brought about sweeping changes to French society, including the (3)_____ of the monarchy, the establishment of a democratic republic, and the (4)_____ of many feudal privileges. Despite its many achievements, however, the Revolution was also characterised by violence, terror, and political (5)_____.

SubQuestion No : 70

Q.70 Select the most appropriate option to fill in blank 5.

- Ans 1. stability
 2. upheaval
 3. harmony
 4. reconciliation

Question ID : 264330165113

Option 1 ID : 264330647575

Option 2 ID : 264330647577

Option 3 ID : 264330647576

Option 4 ID : 264330647578

Status : Not Answered

Chosen Option : --

Comprehension:

In the following passage, some words have been deleted. Read the passage carefully and select the most appropriate option to fill in each blank.

The left handed pages (1)_____ for the student to use individually, but they may of course be used by the (2)_____ as a source of ideas and information on which to base a lesson. The student then has the left-hand page as a/an (3)_____ of what has been taught and can refer to it in the (4)_____. The exercises can be done (5)_____, in class or as homework.

SubQuestion No : 71

Q.71 Select the most appropriate option to fill in blank no.1.

- Ans 1. wrote
 2. written
 3. write
 4. are written

Question ID : 264330167903

Option 1 ID : 264330658531

Option 2 ID : 264330658533

Option 3 ID : 264330658534

Option 4 ID : 264330658532

Status : Answered

Chosen Option : 2

Comprehension:

In the following passage, some words have been deleted. Read the passage carefully and select the most appropriate option to fill in each blank.

The left handed pages (1) _____ for the student to use individually, but they may of course be used by the (2) _____ as a source of ideas and information on which to base a lesson. The student then has the left-hand page as a/an (3) _____ of what has been taught and can refer to it in the (4) _____. The exercises can be done (5) _____, in class or as homework.

SubQuestion No : 72**Q.72 Select the most appropriate option to fill in blank no.2.**

- Ans 1. student
 2. teacher
 3. musician
 4. artist

Question ID : 264330167904
Option 1 ID : 264330658536
Option 2 ID : 264330658537
Option 3 ID : 264330658538
Option 4 ID : 264330658535
Status : Answered
Chosen Option : 2

Comprehension:

In the following passage, some words have been deleted. Read the passage carefully and select the most appropriate option to fill in each blank.

The left handed pages (1) _____ for the student to use individually, but they may of course be used by the (2) _____ as a source of ideas and information on which to base a lesson. The student then has the left-hand page as a/an (3) _____ of what has been taught and can refer to it in the (4) _____. The exercises can be done (5) _____, in class or as homework.

SubQuestion No : 73**Q.73 Select the most appropriate option to fill in blank no.3.**

- Ans 1. record
 2. illustration
 3. allusion
 4. anecdote

Question ID : 264330167905
Option 1 ID : 264330658540
Option 2 ID : 264330658541
Option 3 ID : 264330658539
Option 4 ID : 264330658542
Status : Not Answered
Chosen Option : --

Comprehension:

In the following passage, some words have been deleted. Read the passage carefully and select the most appropriate option to fill in each blank.

The left handed pages (1)_____ for the student to use individually, but they may of course be used by the (2)_____ as a source of ideas and information on which to base a lesson. The student then has the left-hand page as a/an (3)_____ of what has been taught and can refer to it in the (4)_____. The exercises can be done (5)_____, in class or as homework.

SubQuestion No : 74**Q.74 Select the most appropriate option to fill in blank no.4.**

- Ans 1. past
 2. lecture
 3. future
 4. progression

Question ID : 264330167906

Option 1 ID : 264330658543

Option 2 ID : 264330658546

Option 3 ID : 264330658545

Option 4 ID : 264330658544

Status : Answered

Chosen Option : 2

Comprehension:

In the following passage, some words have been deleted. Read the passage carefully and select the most appropriate option to fill in each blank.

The left handed pages (1)_____ for the student to use individually, but they may of course be used by the (2)_____ as a source of ideas and information on which to base a lesson. The student then has the left-hand page as a/an (3)_____ of what has been taught and can refer to it in the (4)_____. The exercises can be done (5)_____, in class or as homework.

SubQuestion No : 75**Q.75 Select the most appropriate option to fill in blank no.5.**

- Ans 1. individually
 2. collaboratively
 3. ideally
 4. publicly

Question ID : 264330167907

Option 1 ID : 264330658548

Option 2 ID : 264330658549

Option 3 ID : 264330658550

Option 4 ID : 264330658547

Status : Answered

Chosen Option : 1

Comprehension:

In the following passage, some words have been deleted. Read the passage carefully and select the most appropriate option to fill in each blank.

The service industry in India is growing 1. _____. Increasing customer expectations have forced organisations in the industry to 2. _____ service innovations and explore ways to improve revenues and profitability. The hotel industry is a good example of the service business 3. _____ organisations are modifying their service delivery 4. _____ to attract greater number of customers. The newly emerging micro-stay segment is 5. _____ space for itself in the hotel industry.

SubQuestion No : 76**Q.76 Select the most appropriate option to fill in blank No. 1.**

- Ans 1. rapidly
 2. rapid
 3. marginally
 4. slow

Question ID : 264330168001

Option 1 ID : 264330658892

Option 2 ID : 264330658891

Option 3 ID : 264330658894

Option 4 ID : 264330658893

Status : Answered

Chosen Option : 1

Comprehension:

In the following passage, some words have been deleted. Read the passage carefully and select the most appropriate option to fill in each blank.

The service industry in India is growing 1. _____. Increasing customer expectations have forced organisations in the industry to 2. _____ service innovations and explore ways to improve revenues and profitability. The hotel industry is a good example of the service business 3. _____ organisations are modifying their service delivery 4. _____ to attract greater number of customers. The newly emerging micro-stay segment is 5. _____ space for itself in the hotel industry.

SubQuestion No : 77**Q.77 Select the most appropriate option to fill in blank No. 2.**

- Ans 1. marvel
 2. criticise
 3. introduce
 4. degenerate

Question ID : 264330168002

Option 1 ID : 264330658898

Option 2 ID : 264330658896

Option 3 ID : 264330658897

Option 4 ID : 264330658895

Status : Not Answered

Chosen Option : --

Comprehension:

In the following passage, some words have been deleted. Read the passage carefully and select the most appropriate option to fill in each blank.

The service industry in India is growing 1. _____. Increasing customer expectations have forced organisations in the industry to 2. _____ service innovations and explore ways to improve revenues and profitability. The hotel industry is a good example of the service business 3. _____ organisations are modifying their service delivery 4. _____ to attract greater number of customers. The newly emerging micro-stay segment is 5. _____ space for itself in the hotel industry.

SubQuestion No : 78

Q.78 Select the most appropriate option to fill in blank No. 3.

- Ans 1. where
 2. whom
 3. when
 4. which

Question ID : 264330168003

Option 1 ID : 264330658902

Option 2 ID : 264330658899

Option 3 ID : 264330658901

Option 4 ID : 264330658900

Status : Answered

Chosen Option : 1

Comprehension:

In the following passage, some words have been deleted. Read the passage carefully and select the most appropriate option to fill in each blank.

The service industry in India is growing 1. _____. Increasing customer expectations have forced organisations in the industry to 2. _____ service innovations and explore ways to improve revenues and profitability. The hotel industry is a good example of the service business 3. _____ organisations are modifying their service delivery 4. _____ to attract greater number of customers. The newly emerging micro-stay segment is 5. _____ space for itself in the hotel industry.

SubQuestion No : 79

Q.79 Select the most appropriate option to fill in blank No. 4.

- Ans 1. issues
 2. tastes
 3. subjects
 4. approaches

Question ID : 264330168004

Option 1 ID : 264330658906

Option 2 ID : 264330658905

Option 3 ID : 264330658904

Option 4 ID : 264330658903

Status : Answered

Chosen Option : 1

Comprehension:

In the following passage, some words have been deleted. Read the passage carefully and select the most appropriate option to fill in each blank.

The service industry in India is growing 1. _____. Increasing customer expectations have forced organisations in the industry to 2. _____ service innovations and explore ways to improve revenues and profitability. The hotel industry is a good example of the service business 3. _____ organisations are modifying their service delivery 4. _____ to attract greater number of customers. The newly emerging micro-stay segment is 5. _____ space for itself in the hotel industry.

SubQuestion No : 80

Q.80 Select the most appropriate option to fill in blank No. 5.

- Ans
- 1. ricocheting
 - 2. counterfeiting
 - 3. generating
 - 4. deteriorating

Question ID : 264330168005

Option 1 ID : 264330658907

Option 2 ID : 264330658908

Option 3 ID : 264330658909

Option 4 ID : 264330658910

Status : Answered

Chosen Option : 3

Comprehension:

In the following passage, some words have been deleted. Read the passage carefully and select the most appropriate option to fill in each blank.

Everyone (1) _____ that paper is made from trees. But when one looks at trees, one cannot imagine that something as soft and (2) _____ as paper is made from a tree that is so hard and strong. Plant materials such as wood are made of fibres known as cellulose. Cellulose is the primary (3) _____ in papermaking. Raw wood is first (4) _____ into pulp, which consists of a mixture of cellulose, lignin, water and some chemicals. The pulp can be made mechanically through grinders or through chemical processes. The paper (5) _____ in this way is weak and is used to make newspapers, magazines and phonebooks.

SubQuestion No : 81

Q.81 Select the most appropriate option to fill in blank number 1.

- Ans
- 1. assures
 - 2. admits
 - 3. knows
 - 4. feels

Question ID : 264330169216

Option 1 ID : 264330663651

Option 2 ID : 264330663653

Option 3 ID : 264330663652

Option 4 ID : 264330663654

Status : Answered

Chosen Option : 3

Comprehension:

In the following passage, some words have been deleted. Read the passage carefully and select the most appropriate option to fill in each blank.

Everyone (1) _____ that paper is made from trees. But when one looks at trees, one cannot imagine that something as soft and (2) _____ as paper is made from a tree that is so hard and strong. Plant materials such as wood are made of fibres known as cellulose. Cellulose is the primary (3) _____ in papermaking. Raw wood is first (4) _____ into pulp, which consists of a mixture of cellulose, lignin, water and some chemicals. The pulp can be made mechanically through grinders or through chemical processes. The paper (5) _____ in this way is weak and is used to make newspapers, magazines and phonebooks.

SubQuestion No : 82

Q.82 Select the most appropriate option to fill in blank number 2.

- Ans 1. dashing
 2. healthy
 3. awful
 4. fragile

Question ID : 264330169217

Option 1 ID : 264330663656

Option 2 ID : 264330663657

Option 3 ID : 264330663658

Option 4 ID : 264330663655

Status : Answered

Chosen Option : 1

Comprehension:

In the following passage, some words have been deleted. Read the passage carefully and select the most appropriate option to fill in each blank.

Everyone (1) _____ that paper is made from trees. But when one looks at trees, one cannot imagine that something as soft and (2) _____ as paper is made from a tree that is so hard and strong. Plant materials such as wood are made of fibres known as cellulose. Cellulose is the primary (3) _____ in papermaking. Raw wood is first (4) _____ into pulp, which consists of a mixture of cellulose, lignin, water and some chemicals. The pulp can be made mechanically through grinders or through chemical processes. The paper (5) _____ in this way is weak and is used to make newspapers, magazines and phonebooks.

SubQuestion No : 83

Q.83 Select the most appropriate option to fill in blank number 3.

- Ans 1. force
 2. advantage
 3. ingredient
 4. choice

Question ID : 264330169218

Option 1 ID : 264330663659

Option 2 ID : 264330663661

Option 3 ID : 264330663662

Option 4 ID : 264330663660

Status : Answered

Chosen Option : 3

Comprehension:

In the following passage, some words have been deleted. Read the passage carefully and select the most appropriate option to fill in each blank.

Everyone (1) _____ that paper is made from trees. But when one looks at trees, one cannot imagine that something as soft and (2) _____ as paper is made from a tree that is so hard and strong. Plant materials such as wood are made of fibres known as cellulose. Cellulose is the primary (3) _____ in papermaking. Raw wood is first (4) _____ into pulp, which consists of a mixture of cellulose, lignin, water and some chemicals. The pulp can be made mechanically through grinders or through chemical processes. The paper (5) _____ in this way is weak and is used to make newspapers, magazines and phonebooks.

SubQuestion No : 84**Q.84 Select the most appropriate option to fill in blank number 4.**

- Ans 1. converted
 2. implied
 3. invested
 4. managed

Question ID : 264330169219

Option 1 ID : 264330663665

Option 2 ID : 264330663663

Option 3 ID : 264330663664

Option 4 ID : 264330663666

Status : Answered

Chosen Option : 3

Comprehension:

In the following passage, some words have been deleted. Read the passage carefully and select the most appropriate option to fill in each blank.

Everyone (1) _____ that paper is made from trees. But when one looks at trees, one cannot imagine that something as soft and (2) _____ as paper is made from a tree that is so hard and strong. Plant materials such as wood are made of fibres known as cellulose. Cellulose is the primary (3) _____ in papermaking. Raw wood is first (4) _____ into pulp, which consists of a mixture of cellulose, lignin, water and some chemicals. The pulp can be made mechanically through grinders or through chemical processes. The paper (5) _____ in this way is weak and is used to make newspapers, magazines and phonebooks.

SubQuestion No : 85**Q.85 Select the most appropriate option to fill in blank number 5.**

- Ans 1. emphasised
 2. involved
 3. considered
 4. produced

Question ID : 264330169220

Option 1 ID : 264330663668

Option 2 ID : 264330663670

Option 3 ID : 264330663669

Option 4 ID : 264330663667

Status : Not Answered

Chosen Option : --

Comprehension:

Read the given passage and answer the questions that follow.

Parents and educators frequently criticise today's youth for their irresponsibility. On the other hand, restrictions are met with resistance from teenagers. Despite parents' concerns that teenagers will abuse their freedom, we are dissatisfied that we are required to adhere to so many regulations. We sincerely hope that teachers and parents will begin to trust our judgment more. As teenagers, we shouldn't be shielded from the harsh realities of the world. In our day and mature, such countless individuals are left to fight for themselves. We are fortunate to live in a safe environment, but we ought to also be free to comprehend the adult world and its requirements of us.

It's important for adults to understand that having fun isn't always a bad thing. The outcome will undoubtedly benefit us in the long run by exposing us to the wider world, but it will not result in a night out with friends watching a movie or a day spent reading rather than studying. It would be beneficial for young people to learn about their limits and how much something is beneficial to us.

We also begin to develop our own perspective on the world around us during adolescence. We open up to friends and younger people more. Adults ought to encourage us to keep these close friendships rather than worrying about how far apart we are from them.

If parents want their teenagers to better understand what freedom entails, they might want to think about letting them work part-time, which is common practice in many countries. This would be preferable to limiting them to a monthly allowance. Working teaches us responsibility for our spending and saving, which is an important life skill. We would be more helpful if we were given the responsibility of managing our own finances, especially when it comes to things like getting the most recent comics or eating pizza with friends. It would be preferable to correct us for occasional extravagant behavior because we may make mistakes. However, we all make errors. Everyone makes errors. We ought to be given the opportunity to learn from our mistakes and accept responsibility for them rather than being held accountable for them.

However, it is essential to emphasise that there should be checks and balances in Freedom. Additionally, unrestricted freedom can result in serious consequences. Who hasn't heard of promising young people running away from their studies? In the same way, we should remember that granting someone freedom does not mean removing the safety net that will catch them if they fall. Numerous teenage criminals have slipped through social networks without being observed. In general, it might be preferable to restrict teenagers' freedom so that they can become more responsible adults in adulthood.

SubQuestion No : 86

Q.86 Select the most appropriate synonym of the word 'comprehend'.

- Ans
- 1. Grasp
 - 2. Judge
 - 3. Appreciate
 - 4. Imply

Question ID : 264330169140

Option 1 ID : 264330663359

Option 2 ID : 264330663360

Option 3 ID : 264330663362

Option 4 ID : 264330663361

Status : Answered

Chosen Option : 3

Comprehension:

Read the given passage and answer the questions that follow.

Parents and educators frequently criticise today's youth for their irresponsibility. On the other hand, restrictions are met with resistance from teenagers. Despite parents' concerns that teenagers will abuse their freedom, we are dissatisfied that we are required to adhere to so many regulations. We sincerely hope that teachers and parents will begin to trust our judgment more. As teenagers, we shouldn't be shielded from the harsh realities of the world. In our day and mature, such countless individuals are left to fight for themselves. We are fortunate to live in a safe environment, but we ought to also be free to comprehend the adult world and its requirements of us.

It's important for adults to understand that having fun isn't always a bad thing. The outcome will undoubtedly benefit us in the long run by exposing us to the wider world, but it will not result in a night out with friends watching a movie or a day spent reading rather than studying. It would be beneficial for young people to learn about their limits and how much something is beneficial to us.

We also begin to develop our own perspective on the world around us during adolescence. We open up to friends and younger people more. Adults ought to encourage us to keep these close friendships rather than worrying about how far apart we are from them.

If parents want their teenagers to better understand what freedom entails, they might want to think about letting them work part-time, which is common practice in many countries. This would be preferable to limiting them to a monthly allowance. Working teaches us responsibility for our spending and saving, which is an important life skill. We would be more helpful if we were given the responsibility of managing our own finances, especially when it comes to things like getting the most recent comics or eating pizza with friends. It would be preferable to correct us for occasional extravagant behavior because we may make mistakes. However, we all make errors. Everyone makes errors. We ought to be given the opportunity to learn from our mistakes and accept responsibility for them rather than being held accountable for them.

However, it is essential to emphasise that there should be checks and balances in Freedom. Additionally, unrestricted freedom can result in serious consequences. Who hasn't heard of promising young people running away from their studies? In the same way, we should remember that granting someone freedom does not mean removing the safety net that will catch them if they fall. Numerous teenage criminals have slipped through social networks without being observed. In general, it might be preferable to restrict teenagers' freedom so that they can become more responsible adults in adulthood.

SubQuestion No : 87

Q.87 Based on your reading of the passage, select the correct statement.

- Ans
- 1. Young people are more receptive to friends.
 - 2. No obstacles in freedom will make responsible adults.
 - 3. Learning environment should be challenging for the youth.
 - 4. There should be no checks and balances in adolescence.

Question ID : 264330169141

Option 1 ID : 264330663365

Option 2 ID : 264330663363

Option 3 ID : 264330663364

Option 4 ID : 264330663366

Status : Not Answered

Chosen Option : --

Comprehension:

Read the given passage and answer the questions that follow.

Parents and educators frequently criticise today's youth for their irresponsibility. On the other hand, restrictions are met with resistance from teenagers. Despite parents' concerns that teenagers will abuse their freedom, we are dissatisfied that we are required to adhere to so many regulations. We sincerely hope that teachers and parents will begin to trust our judgment more. As teenagers, we shouldn't be shielded from the harsh realities of the world. In our day and mature, such countless individuals are left to fight for themselves. We are fortunate to live in a safe environment, but we ought to also be free to comprehend the adult world and its requirements of us.

It's important for adults to understand that having fun isn't always a bad thing. The outcome will undoubtedly benefit us in the long run by exposing us to the wider world, but it will not result in a night out with friends watching a movie or a day spent reading rather than studying. It would be beneficial for young people to learn about their limits and how much something is beneficial to us.

We also begin to develop our own perspective on the world around us during adolescence. We open up to friends and younger people more. Adults ought to encourage us to keep these close friendships rather than worrying about how far apart we are from them.

If parents want their teenagers to better understand what freedom entails, they might want to think about letting them work part-time, which is common practice in many countries. This would be preferable to limiting them to a monthly allowance. Working teaches us responsibility for our spending and saving, which is an important life skill. We would be more helpful if we were given the responsibility of managing our own finances, especially when it comes to things like getting the most recent comics or eating pizza with friends. It would be preferable to correct us for occasional extravagant behavior because we may make mistakes. However, we all make errors. Everyone makes errors. We ought to be given the opportunity to learn from our mistakes and accept responsibility for them rather than being held accountable for them.

However, it is essential to emphasise that there should be checks and balances in Freedom. Additionally, unrestricted freedom can result in serious consequences. Who hasn't heard of promising young people running away from their studies? In the same way, we should remember that granting someone freedom does not mean removing the safety net that will catch them if they fall. Numerous teenage criminals have slipped through social networks without being observed. In general, it might be preferable to restrict teenagers' freedom so that they can become more responsible adults in adulthood.

SubQuestion No : 88

Q.88 Identify the tone of the passage.

- Ans
- 1. Descriptive
 - 2. Fictional
 - 3. Critical
 - 4. Comical

Question ID : 264330169138

Option 1 ID : 264330663352

Option 2 ID : 264330663354

Option 3 ID : 264330663351

Option 4 ID : 264330663353

Status : Answered

Chosen Option : 3

Comprehension:

Read the given passage and answer the questions that follow.

Parents and educators frequently criticise today's youth for their irresponsibility. On the other hand, restrictions are met with resistance from teenagers. Despite parents' concerns that teenagers will abuse their freedom, we are dissatisfied that we are required to adhere to so many regulations. We sincerely hope that teachers and parents will begin to trust our judgment more. As teenagers, we shouldn't be shielded from the harsh realities of the world. In our day and mature, such countless individuals are left to fight for themselves. We are fortunate to live in a safe environment, but we ought to also be free to comprehend the adult world and its requirements of us.

It's important for adults to understand that having fun isn't always a bad thing. The outcome will undoubtedly benefit us in the long run by exposing us to the wider world, but it will not result in a night out with friends watching a movie or a day spent reading rather than studying. It would be beneficial for young people to learn about their limits and how much something is beneficial to us.

We also begin to develop our own perspective on the world around us during adolescence. We open up to friends and younger people more. Adults ought to encourage us to keep these close friendships rather than worrying about how far apart we are from them.

If parents want their teenagers to better understand what freedom entails, they might want to think about letting them work part-time, which is common practice in many countries. This would be preferable to limiting them to a monthly allowance. Working teaches us responsibility for our spending and saving, which is an important life skill. We would be more helpful if we were given the responsibility of managing our own finances, especially when it comes to things like getting the most recent comics or eating pizza with friends. It would be preferable to correct us for occasional extravagant behavior because we may make mistakes. However, we all make errors. Everyone makes errors. We ought to be given the opportunity to learn from our mistakes and accept responsibility for them rather than being held accountable for them.

However, it is essential to emphasise that there should be checks and balances in Freedom. Additionally, unrestricted freedom can result in serious consequences. Who hasn't heard of promising young people running away from their studies? In the same way, we should remember that granting someone freedom does not mean removing the safety net that will catch them if they fall. Numerous teenage criminals have slipped through social networks without being observed. In general, it might be preferable to restrict teenagers' freedom so that they can become more responsible adults in adulthood.

SubQuestion No : 89

Q.89 Select the most appropriate title for the passage.

- Ans
- 1. Parents and Adults
 - 2. Youth and Learning
 - 3. Teenage Problems
 - 4. More Freedom For Greater Responsibility

Question ID : 264330169137

Option 1 ID : 264330663347

Option 2 ID : 264330663350

Option 3 ID : 264330663348

Option 4 ID : 264330663349

Status : Answered

Chosen Option : 2

Comprehension:

Read the given passage and answer the questions that follow.

Parents and educators frequently criticise today's youth for their irresponsibility. On the other hand, restrictions are met with resistance from teenagers. Despite parents' concerns that teenagers will abuse their freedom, we are dissatisfied that we are required to adhere to so many regulations. We sincerely hope that teachers and parents will begin to trust our judgment more. As teenagers, we shouldn't be shielded from the harsh realities of the world. In our day and mature, such countless individuals are left to fight for themselves. We are fortunate to live in a safe environment, but we ought to also be free to comprehend the adult world and its requirements of us.

It's important for adults to understand that having fun isn't always a bad thing. The outcome will undoubtedly benefit us in the long run by exposing us to the wider world, but it will not result in a night out with friends watching a movie or a day spent reading rather than studying. It would be beneficial for young people to learn about their limits and how much something is beneficial to us.

We also begin to develop our own perspective on the world around us during adolescence. We open up to friends and younger people more. Adults ought to encourage us to keep these close friendships rather than worrying about how far apart we are from them.

If parents want their teenagers to better understand what freedom entails, they might want to think about letting them work part-time, which is common practice in many countries. This would be preferable to limiting them to a monthly allowance. Working teaches us responsibility for our spending and saving, which is an important life skill. We would be more helpful if we were given the responsibility of managing our own finances, especially when it comes to things like getting the most recent comics or eating pizza with friends. It would be preferable to correct us for occasional extravagant behavior because we may make mistakes. However, we all make errors. Everyone makes errors. We ought to be given the opportunity to learn from our mistakes and accept responsibility for them rather than being held accountable for them.

However, it is essential to emphasise that there should be checks and balances in Freedom. Additionally, unrestricted freedom can result in serious consequences. Who hasn't heard of promising young people running away from their studies? In the same way, we should remember that granting someone freedom does not mean removing the safety net that will catch them if they fall. Numerous teenage criminals have slipped through social networks without being observed. In general, it might be preferable to restrict teenagers' freedom so that they can become more responsible adults in adulthood.

SubQuestion No : 90

Q.90 Select the central theme of the passage.

- Ans
- 1. Family relationships
 - 2. Work job stress
 - 3. Learning and environment
 - 4. Understanding liberty

Question ID : 264330169139

Option 1 ID : 264330663355

Option 2 ID : 264330663356

Option 3 ID : 264330663357

Option 4 ID : 264330663358

Status : Not Answered

Chosen Option : --

Comprehension:

Read the given passage and answer the questions that follow.

The Constituent Assembly of India was a body that was set up to draft and enact a new Constitution for India, which became the supreme law of the country upon its adoption in 1950. The assembly was constituted in 1946, after India's independence from British rule was assured. It was composed of 389 members, including 296 representatives from British India and 93 from the princely states. The assembly held its first session on 9 December 1946 and continued to work for nearly 3 years to complete the drafting of the Constitution. The final document was adopted on 26 November 1949 and came into effect on 26 January 1950, marking the beginning of India's status as a republic.

One of the key features of the Constituent Assembly was its inclusivity. The members of the assembly were drawn from diverse backgrounds and political persuasions, representing a broad spectrum of Indian society. They included representatives from different castes, religions and regions, as well as members with varying levels of education and political experience. This diversity was reflected in the debates and discussions that took place within the assembly, which were often passionate and contentious, but ultimately led to a constitution that was widely regarded as fair and balanced.

The drafting of the Constitution was a complex and lengthy process that required extensive debate and negotiation. The members of the assembly were divided into several committees that were responsible for different aspects of the Constitution, such as the Fundamental Rights Committee, the Union Powers Committee and the Drafting Committee. The most important of these committees was the Drafting Committee, which was headed by Dr. BR Ambedkar, a prominent leader and jurist who played a key role in shaping the final document. The Constitution that emerged from the Constituent Assembly was a historic document that set the framework for India's democracy and governance. It established India as a sovereign, socialist, secular and democratic republic and outlined a system of government that was based on the principles of separation of powers, federalism and fundamental rights. The Constitution also enshrined a number of progressive provisions that reflected the aspirations of the Indian people, such as the right to equality, the right to freedom of speech and expression and the right to education.

The enforcement of the Constitution on 26 January 1950 was a momentous occasion in Indian history, marking the culmination of a long and hard-fought struggle for independence and self-rule. The day is celebrated every year as Republic Day, a national holiday that is marked by parades, speeches and cultural events across the country. The Constitution remains the cornerstone of India's democracy and is widely regarded as one of the most important and progressive documents of its kind in the world.

Overall, the Constituent Assembly of India was a remarkable achievement, reflecting the spirit of cooperation and compromise that characterised India's struggle for independence. Its legacy continues to shape India's political and social landscape to this day, and its example serves as an inspiration for other countries that seek to establish democratic and inclusive systems of governance.

SubQuestion No : 91

Q.91 Which of the following provisions reflects the aspiration of Indian people in the constitution?

Ans ✓ 1. Right to equality

✗ 2. Fundamental rights

✗ 3. Sovereign and socialist country

✗ 4. Separation of powers

Question ID : 264330168493

Option 1 ID : 264330660807

Option 2 ID : 264330660808

Option 3 ID : 264330660810

Option 4 ID : 264330660809

Status : Answered

Chosen Option : 2

Comprehension:

Read the given passage and answer the questions that follow.

The Constituent Assembly of India was a body that was set up to draft and enact a new Constitution for India, which became the supreme law of the country upon its adoption in 1950. The assembly was constituted in 1946, after India's independence from British rule was assured. It was composed of 389 members, including 296 representatives from British India and 93 from the princely states. The assembly held its first session on 9 December 1946 and continued to work for nearly 3 years to complete the drafting of the Constitution. The final document was adopted on 26 November 1949 and came into effect on 26 January 1950, marking the beginning of India's status as a republic.

One of the key features of the Constituent Assembly was its inclusivity. The members of the assembly were drawn from diverse backgrounds and political persuasions, representing a broad spectrum of Indian society. They included representatives from different castes, religions and regions, as well as members with varying levels of education and political experience. This diversity was reflected in the debates and discussions that took place within the assembly, which were often passionate and contentious, but ultimately led to a constitution that was widely regarded as fair and balanced.

The drafting of the Constitution was a complex and lengthy process that required extensive debate and negotiation. The members of the assembly were divided into several committees that were responsible for different aspects of the Constitution, such as the Fundamental Rights Committee, the Union Powers Committee and the Drafting Committee. The most important of these committees was the Drafting Committee, which was headed by Dr. BR Ambedkar, a prominent leader and jurist who played a key role in shaping the final document. The Constitution that emerged from the Constituent Assembly was a historic document that set the framework for India's democracy and governance. It established India as a sovereign, socialist, secular and democratic republic and outlined a system of government that was based on the principles of separation of powers, federalism and fundamental rights. The Constitution also enshrined a number of progressive provisions that reflected the aspirations of the Indian people, such as the right to equality, the right to freedom of speech and expression and the right to education.

The enforcement of the Constitution on 26 January 1950 was a momentous occasion in Indian history, marking the culmination of a long and hard-fought struggle for independence and self-rule. The day is celebrated every year as Republic Day, a national holiday that is marked by parades, speeches and cultural events across the country. The Constitution remains the cornerstone of India's democracy and is widely regarded as one of the most important and progressive documents of its kind in the world.

Overall, the Constituent Assembly of India was a remarkable achievement, reflecting the spirit of cooperation and compromise that characterised India's struggle for independence. Its legacy continues to shape India's political and social landscape to this day, and its example serves as an inspiration for other countries that seek to establish democratic and inclusive systems of governance.

SubQuestion No : 92

Q.92 Which of the following would be the most appropriate title for the given passage?

- Ans**
- 1. India's Struggle for Independence
 - 2. The Role of Jawaharlal Nehru in Indian Politics
 - 3. The History of Indian National Congress
 - 4. The Formation of Indian Constitution

Question ID : 264330168491

Option 1 ID : 264330660801

Option 2 ID : 264330660802

Option 3 ID : 264330660800

Option 4 ID : 264330660799

Status : Answered

Chosen Option : 4

Comprehension:

Read the given passage and answer the questions that follow.

The Constituent Assembly of India was a body that was set up to draft and enact a new Constitution for India, which became the supreme law of the country upon its adoption in 1950. The assembly was constituted in 1946, after India's independence from British rule was assured. It was composed of 389 members, including 296 representatives from British India and 93 from the princely states. The assembly held its first session on 9 December 1946 and continued to work for nearly 3 years to complete the drafting of the Constitution. The final document was adopted on 26 November 1949 and came into effect on 26 January 1950, marking the beginning of India's status as a republic.

One of the key features of the Constituent Assembly was its inclusivity. The members of the assembly were drawn from diverse backgrounds and political persuasions, representing a broad spectrum of Indian society. They included representatives from different castes, religions and regions, as well as members with varying levels of education and political experience. This diversity was reflected in the debates and discussions that took place within the assembly, which were often passionate and contentious, but ultimately led to a constitution that was widely regarded as fair and balanced.

The drafting of the Constitution was a complex and lengthy process that required extensive debate and negotiation. The members of the assembly were divided into several committees that were responsible for different aspects of the Constitution, such as the Fundamental Rights Committee, the Union Powers Committee and the Drafting Committee. The most important of these committees was the Drafting Committee, which was headed by Dr. BR Ambedkar, a prominent leader and jurist who played a key role in shaping the final document. The Constitution that emerged from the Constituent Assembly was a historic document that set the framework for India's democracy and governance. It established India as a sovereign, socialist, secular and democratic republic and outlined a system of government that was based on the principles of separation of powers, federalism and fundamental rights. The Constitution also enshrined a number of progressive provisions that reflected the aspirations of the Indian people, such as the right to equality, the right to freedom of speech and expression and the right to education.

The enforcement of the Constitution on 26 January 1950 was a momentous occasion in Indian history, marking the culmination of a long and hard-fought struggle for independence and self-rule. The day is celebrated every year as Republic Day, a national holiday that is marked by parades, speeches and cultural events across the country. The Constitution remains the cornerstone of India's democracy and is widely regarded as one of the most important and progressive documents of its kind in the world.

Overall, the Constituent Assembly of India was a remarkable achievement, reflecting the spirit of cooperation and compromise that characterised India's struggle for independence. Its legacy continues to shape India's political and social landscape to this day, and its example serves as an inspiration for other countries that seek to establish democratic and inclusive systems of governance.

SubQuestion No : 93

Q.93 When was the Constitution of India adopted?

- Ans
- 1. 26 January 1946
 - 2. 9 December 1946
 - 3. 26 November 1949
 - 4. 26 January 1950

Question ID : 264330168492

Option 1 ID : 264330660803

Option 2 ID : 264330660805

Option 3 ID : 264330660806

Option 4 ID : 264330660804

Status : Answered

Chosen Option : 3

Comprehension:

Read the given passage and answer the questions that follow.

The Constituent Assembly of India was a body that was set up to draft and enact a new Constitution for India, which became the supreme law of the country upon its adoption in 1950. The assembly was constituted in 1946, after India's independence from British rule was assured. It was composed of 389 members, including 296 representatives from British India and 93 from the princely states. The assembly held its first session on 9 December 1946 and continued to work for nearly 3 years to complete the drafting of the Constitution. The final document was adopted on 26 November 1949 and came into effect on 26 January 1950, marking the beginning of India's status as a republic.

One of the key features of the Constituent Assembly was its inclusivity. The members of the assembly were drawn from diverse backgrounds and political persuasions, representing a broad spectrum of Indian society. They included representatives from different castes, religions and regions, as well as members with varying levels of education and political experience. This diversity was reflected in the debates and discussions that took place within the assembly, which were often passionate and contentious, but ultimately led to a constitution that was widely regarded as fair and balanced.

The drafting of the Constitution was a complex and lengthy process that required extensive debate and negotiation. The members of the assembly were divided into several committees that were responsible for different aspects of the Constitution, such as the Fundamental Rights Committee, the Union Powers Committee and the Drafting Committee. The most important of these committees was the Drafting Committee, which was headed by Dr. BR Ambedkar, a prominent leader and jurist who played a key role in shaping the final document. The Constitution that emerged from the Constituent Assembly was a historic document that set the framework for India's democracy and governance. It established India as a sovereign, socialist, secular and democratic republic and outlined a system of government that was based on the principles of separation of powers, federalism and fundamental rights. The Constitution also enshrined a number of progressive provisions that reflected the aspirations of the Indian people, such as the right to equality, the right to freedom of speech and expression and the right to education.

The enforcement of the Constitution on 26 January 1950 was a momentous occasion in Indian history, marking the culmination of a long and hard-fought struggle for independence and self-rule. The day is celebrated every year as Republic Day, a national holiday that is marked by parades, speeches and cultural events across the country. The Constitution remains the cornerstone of India's democracy and is widely regarded as one of the most important and progressive documents of its kind in the world.

Overall, the Constituent Assembly of India was a remarkable achievement, reflecting the spirit of cooperation and compromise that characterised India's struggle for independence. Its legacy continues to shape India's political and social landscape to this day, and its example serves as an inspiration for other countries that seek to establish democratic and inclusive systems of governance.

SubQuestion No : 94

Q.94 The passage mentions the importance of inclusivity in the Indian Constitution. Which of the following real-world scenarios is the most similar to this theme?

- Ans** ✓ 1. A company that hires employees of different ages, genders and backgrounds to create a more diverse workforce
- ✗ 2. A restaurant that only serves vegetarian food to cater to people with different dietary needs
- ✗ 3. A sports team that only recruits players from a specific region to create a sense of community and shared identity
- ✗ 4. A museum that displays art from various themes to promote diversity and understanding

Question ID : 264330168495

Option 1 ID : 264330660817

Option 2 ID : 264330660815

Option 3 ID : 264330660818

Option 4 ID : 264330660816

Status : Not Answered

Chosen Option : --

Comprehension:

Read the given passage and answer the questions that follow.

The Constituent Assembly of India was a body that was set up to draft and enact a new Constitution for India, which became the supreme law of the country upon its adoption in 1950. The assembly was constituted in 1946, after India's independence from British rule was assured. It was composed of 389 members, including 296 representatives from British India and 93 from the princely states. The assembly held its first session on 9 December 1946 and continued to work for nearly 3 years to complete the drafting of the Constitution. The final document was adopted on 26 November 1949 and came into effect on 26 January 1950, marking the beginning of India's status as a republic.

One of the key features of the Constituent Assembly was its inclusivity. The members of the assembly were drawn from diverse backgrounds and political persuasions, representing a broad spectrum of Indian society. They included representatives from different castes, religions and regions, as well as members with varying levels of education and political experience. This diversity was reflected in the debates and discussions that took place within the assembly, which were often passionate and contentious, but ultimately led to a constitution that was widely regarded as fair and balanced.

The drafting of the Constitution was a complex and lengthy process that required extensive debate and negotiation. The members of the assembly were divided into several committees that were responsible for different aspects of the Constitution, such as the Fundamental Rights Committee, the Union Powers Committee and the Drafting Committee. The most important of these committees was the Drafting Committee, which was headed by Dr. BR Ambedkar, a prominent leader and jurist who played a key role in shaping the final document. The Constitution that emerged from the Constituent Assembly was a historic document that set the framework for India's democracy and governance. It established India as a sovereign, socialist, secular and democratic republic and outlined a system of government that was based on the principles of separation of powers, federalism and fundamental rights. The Constitution also enshrined a number of progressive provisions that reflected the aspirations of the Indian people, such as the right to equality, the right to freedom of speech and expression and the right to education.

The enforcement of the Constitution on 26 January 1950 was a momentous occasion in Indian history, marking the culmination of a long and hard-fought struggle for independence and self-rule. The day is celebrated every year as Republic Day, a national holiday that is marked by parades, speeches and cultural events across the country. The Constitution remains the cornerstone of India's democracy and is widely regarded as one of the most important and progressive documents of its kind in the world.

Overall, the Constituent Assembly of India was a remarkable achievement, reflecting the spirit of cooperation and compromise that characterised India's struggle for independence. Its legacy continues to shape India's political and social landscape to this day, and its example serves as an inspiration for other countries that seek to establish democratic and inclusive systems of governance.

SubQuestion No : 95

Q.95 Find the ANTONYM of the word 'combative' from the passage.

- Ans 1. Contentious
 2. Agreeable
 3. Secular
 4. Legacy

Question ID : 264330168494

Option 1 ID : 264330660811

Option 2 ID : 264330660812

Option 3 ID : 264330660813

Option 4 ID : 264330660814

Status : Not Answered

Chosen Option : --

Comprehension:

Read the given passage and answer the questions that follow.

Endangered species are those that are at risk of becoming extinct due to various factors such as habitat destruction, poaching, pollution and climate change. The loss of biodiversity and the extinction of species are major environmental concerns, as they can have a ripple effect on the entire ecosystem. Endangered species are important to protect as they play vital roles in maintaining the balance of the ecosystem and contribute to the health and well-being of the planet and its inhabitants.

The importance of conserving endangered species is multifaceted. First and foremost, the loss of biodiversity can have a profound impact on the environment. Every species has a unique role to play in the ecosystem, and their disappearance can trigger a domino effect that can ultimately lead to ecosystem collapse. For example, pollinators such as bees and butterflies play a critical role in maintaining the health and productivity of plant communities. Without them, many plants would not be able to reproduce, and the animals that rely on those plants for food and habitat would also suffer. Similarly, predators such as wolves and lions help to regulate prey populations and prevent overgrazing, which can have negative impacts on the environment.

Endangered species also have cultural and economic value. Many indigenous cultures have close relationships with endangered species and consider them to be an integral part of their heritage and identity. For example, the Maasai people of Kenya have a strong cultural connection to elephants and consider them to be sacred animals. In addition, endangered species can be important sources of income for local communities through ecotourism. For example, the mountain gorillas of Rwanda and Uganda are a major draw for tourists, generating significant revenue for local economies.

Furthermore, endangered species can also have scientific and medical value. Many species contain unique genetic material that can be used to develop new medicines and treatments for a variety of diseases. For example, the rosy periwinkle, a plant species found only in Madagascar, produces two drugs that are used to treat certain types of cancer. In addition, endangered species can serve as indicators of environmental health. Changes in the populations of certain species can indicate changes in the quality of the environment, alerting scientists to potential issues that may require attention.

Conservation efforts are essential to protecting endangered species and preserving biodiversity. These efforts can take many forms, such as habitat restoration, anti-poaching measures and captive breeding programmes. Habitat restoration involves identifying and protecting critical habitats for endangered species and restoring degraded areas to their natural state. Anti-poaching measures are necessary to prevent the illegal hunting and trafficking of endangered species. Captive breeding programmes are used to breed and raise endangered species in captivity with the goal of releasing them into the wild. While these efforts can be costly and time-consuming, they are necessary to ensure the survival of endangered species.

Another key aspect of conservation is education and awareness-raising. Many people are unaware of the threats facing endangered species and the importance of biodiversity. Educating the public and raising awareness can help to promote greater appreciation for the natural world and inspire action to protect it. Additionally, outreach programmes can work with local communities to promote sustainable practices and reduce the impact of human activities on the environment.

In conclusion, the conservation of endangered species is a critical issue that affects the health and well-being of the planet and its inhabitants. Protecting biodiversity is important for maintaining the balance of the ecosystem, preserving cultural and economic value and advancing scientific and medical research. Conservation efforts, including habitat restoration, anti-poaching measures, captive breeding programmes and education and awareness-raising, are necessary to ensure the survival of endangered species and promote a sustainable future.

SubQuestion No : 96

Q.96 Which of the following statements best explains how mountain gorillas are contributing to the local economy of Rwanda?

- Ans**
- 1. Mountain gorillas are kept in captivity and rented out for scientific research, generating significant revenue.
 - 2. Rwanda exports mountain gorilla products such as ivory and hides, generating significant revenue.
 - 3. Mountain gorillas are a major tourist attraction, generating significant revenue through ecotourism.
 - 4. Mountain gorillas are hunted for their meat and sold to the local markets, generating significant revenue.

Question ID : 264330168458

Option 1 ID : 264330660682

Option 2 ID : 264330660680

Option 3 ID : 264330660681

Option 4 ID : 264330660679

Status : Answered

Chosen Option : 3

Comprehension:

Read the given passage and answer the questions that follow.

Endangered species are those that are at risk of becoming extinct due to various factors such as habitat destruction, poaching, pollution and climate change. The loss of biodiversity and the extinction of species are major environmental concerns, as they can have a ripple effect on the entire ecosystem. Endangered species are important to protect as they play vital roles in maintaining the balance of the ecosystem and contribute to the health and well-being of the planet and its inhabitants.

The importance of conserving endangered species is multifaceted. First and foremost, the loss of biodiversity can have a profound impact on the environment. Every species has a unique role to play in the ecosystem, and their disappearance can trigger a domino effect that can ultimately lead to ecosystem collapse. For example, pollinators such as bees and butterflies play a critical role in maintaining the health and productivity of plant communities. Without them, many plants would not be able to reproduce, and the animals that rely on those plants for food and habitat would also suffer. Similarly, predators such as wolves and lions help to regulate prey populations and prevent overgrazing, which can have negative impacts on the environment.

Endangered species also have cultural and economic value. Many indigenous cultures have close relationships with endangered species and consider them to be an integral part of their heritage and identity. For example, the Maasai people of Kenya have a strong cultural connection to elephants and consider them to be sacred animals. In addition, endangered species can be important sources of income for local communities through ecotourism. For example, the mountain gorillas of Rwanda and Uganda are a major draw for tourists, generating significant revenue for local economies.

Furthermore, endangered species can also have scientific and medical value. Many species contain unique genetic material that can be used to develop new medicines and treatments for a variety of diseases. For example, the rosy periwinkle, a plant species found only in Madagascar, produces two drugs that are used to treat certain types of cancer. In addition, endangered species can serve as indicators of environmental health. Changes in the populations of certain species can indicate changes in the quality of the environment, alerting scientists to potential issues that may require attention.

Conservation efforts are essential to protecting endangered species and preserving biodiversity. These efforts can take many forms, such as habitat restoration, anti-poaching measures and captive breeding programmes. Habitat restoration involves identifying and protecting critical habitats for endangered species and restoring degraded areas to their natural state. Anti-poaching measures are necessary to prevent the illegal hunting and trafficking of endangered species. Captive breeding programmes are used to breed and raise endangered species in captivity with the goal of releasing them into the wild. While these efforts can be costly and time-consuming, they are necessary to ensure the survival of endangered species.

Another key aspect of conservation is education and awareness-raising. Many people are unaware of the threats facing endangered species and the importance of biodiversity. Educating the public and raising awareness can help to promote greater appreciation for the natural world and inspire action to protect it. Additionally, outreach programmes can work with local communities to promote sustainable practices and reduce the impact of human activities on the environment.

In conclusion, the conservation of endangered species is a critical issue that affects the health and well-being of the planet and its inhabitants. Protecting biodiversity is important for maintaining the balance of the ecosystem, preserving cultural and economic value and advancing scientific and medical research. Conservation efforts, including habitat restoration, anti-poaching measures, captive breeding programmes and education and awareness-raising, are necessary to ensure the survival of endangered species and promote a sustainable future.

SubQuestion No : 97

Q.97 Which of the following statements can be inferred from the passage?

- Ans
- 1. Captive breeding programmes are the only effective way to protect endangered species.
 - 2. Endangered species have no economic value and should not be conserved.
 - 3. Conserving endangered species is important for maintaining the balance of the ecosystem and preserving cultural and economic value.
 - 4. The loss of biodiversity has no significant impact on the environment.

Question ID : 264330168457

Option 1 ID : 264330660678

Option 2 ID : 264330660675

Option 3 ID : 264330660677

Option 4 ID : 264330660676

Status : Not Answered

Chosen Option : --

Comprehension:

Read the given passage and answer the questions that follow.

Endangered species are those that are at risk of becoming extinct due to various factors such as habitat destruction, poaching, pollution and climate change. The loss of biodiversity and the extinction of species are major environmental concerns, as they can have a ripple effect on the entire ecosystem. Endangered species are important to protect as they play vital roles in maintaining the balance of the ecosystem and contribute to the health and well-being of the planet and its inhabitants.

The importance of conserving endangered species is multifaceted. First and foremost, the loss of biodiversity can have a profound impact on the environment. Every species has a unique role to play in the ecosystem, and their disappearance can trigger a domino effect that can ultimately lead to ecosystem collapse. For example, pollinators such as bees and butterflies play a critical role in maintaining the health and productivity of plant communities. Without them, many plants would not be able to reproduce, and the animals that rely on those plants for food and habitat would also suffer. Similarly, predators such as wolves and lions help to regulate prey populations and prevent overgrazing, which can have negative impacts on the environment.

Endangered species also have cultural and economic value. Many indigenous cultures have close relationships with endangered species and consider them to be an integral part of their heritage and identity. For example, the Maasai people of Kenya have a strong cultural connection to elephants and consider them to be sacred animals. In addition, endangered species can be important sources of income for local communities through ecotourism. For example, the mountain gorillas of Rwanda and Uganda are a major draw for tourists, generating significant revenue for local economies.

Furthermore, endangered species can also have scientific and medical value. Many species contain unique genetic material that can be used to develop new medicines and treatments for a variety of diseases. For example, the rosy periwinkle, a plant species found only in Madagascar, produces two drugs that are used to treat certain types of cancer. In addition, endangered species can serve as indicators of environmental health. Changes in the populations of certain species can indicate changes in the quality of the environment, alerting scientists to potential issues that may require attention.

Conservation efforts are essential to protecting endangered species and preserving biodiversity. These efforts can take many forms, such as habitat restoration, anti-poaching measures and captive breeding programmes. Habitat restoration involves identifying and protecting critical habitats for endangered species and restoring degraded areas to their natural state. Anti-poaching measures are necessary to prevent the illegal hunting and trafficking of endangered species. Captive breeding programmes are used to breed and raise endangered species in captivity with the goal of releasing them into the wild. While these efforts can be costly and time-consuming, they are necessary to ensure the survival of endangered species.

Another key aspect of conservation is education and awareness-raising. Many people are unaware of the threats facing endangered species and the importance of biodiversity. Educating the public and raising awareness can help to promote greater appreciation for the natural world and inspire action to protect it. Additionally, outreach programmes can work with local communities to promote sustainable practices and reduce the impact of human activities on the environment.

In conclusion, the conservation of endangered species is a critical issue that affects the health and well-being of the planet and its inhabitants. Protecting biodiversity is important for maintaining the balance of the ecosystem, preserving cultural and economic value and advancing scientific and medical research. Conservation efforts, including habitat restoration, anti-poaching measures, captive breeding programmes and education and awareness-raising, are necessary to ensure the survival of endangered species and promote a sustainable future.

SubQuestion No : 98

Q.98 Find the ANTONYM of the word 'halt' from the passage.

- Ans
- 1. Captive
 - 2. Hides
 - 3. Trigger
 - 4. Trafficking

Question ID : 264330168459

Option 1 ID : 264330660684

Option 2 ID : 264330660685

Option 3 ID : 264330660686

Option 4 ID : 264330660683

Status : Answered

Chosen Option : 3

Comprehension:

Read the given passage and answer the questions that follow.

Endangered species are those that are at risk of becoming extinct due to various factors such as habitat destruction, poaching, pollution and climate change. The loss of biodiversity and the extinction of species are major environmental concerns, as they can have a ripple effect on the entire ecosystem. Endangered species are important to protect as they play vital roles in maintaining the balance of the ecosystem and contribute to the health and well-being of the planet and its inhabitants.

The importance of conserving endangered species is multifaceted. First and foremost, the loss of biodiversity can have a profound impact on the environment. Every species has a unique role to play in the ecosystem, and their disappearance can trigger a domino effect that can ultimately lead to ecosystem collapse. For example, pollinators such as bees and butterflies play a critical role in maintaining the health and productivity of plant communities. Without them, many plants would not be able to reproduce, and the animals that rely on those plants for food and habitat would also suffer. Similarly, predators such as wolves and lions help to regulate prey populations and prevent overgrazing, which can have negative impacts on the environment.

Endangered species also have cultural and economic value. Many indigenous cultures have close relationships with endangered species and consider them to be an integral part of their heritage and identity. For example, the Maasai people of Kenya have a strong cultural connection to elephants and consider them to be sacred animals. In addition, endangered species can be important sources of income for local communities through ecotourism. For example, the mountain gorillas of Rwanda and Uganda are a major draw for tourists, generating significant revenue for local economies.

Furthermore, endangered species can also have scientific and medical value. Many species contain unique genetic material that can be used to develop new medicines and treatments for a variety of diseases. For example, the rosy periwinkle, a plant species found only in Madagascar, produces two drugs that are used to treat certain types of cancer. In addition, endangered species can serve as indicators of environmental health. Changes in the populations of certain species can indicate changes in the quality of the environment, alerting scientists to potential issues that may require attention.

Conservation efforts are essential to protecting endangered species and preserving biodiversity. These efforts can take many forms, such as habitat restoration, anti-poaching measures and captive breeding programmes. Habitat restoration involves identifying and protecting critical habitats for endangered species and restoring degraded areas to their natural state. Anti-poaching measures are necessary to prevent the illegal hunting and trafficking of endangered species. Captive breeding programmes are used to breed and raise endangered species in captivity with the goal of releasing them into the wild. While these efforts can be costly and time-consuming, they are necessary to ensure the survival of endangered species.

Another key aspect of conservation is education and awareness-raising. Many people are unaware of the threats facing endangered species and the importance of biodiversity. Educating the public and raising awareness can help to promote greater appreciation for the natural world and inspire action to protect it. Additionally, outreach programmes can work with local communities to promote sustainable practices and reduce the impact of human activities on the environment.

In conclusion, the conservation of endangered species is a critical issue that affects the health and well-being of the planet and its inhabitants. Protecting biodiversity is important for maintaining the balance of the ecosystem, preserving cultural and economic value and advancing scientific and medical research. Conservation efforts, including habitat restoration, anti-poaching measures, captive breeding programmes and education and awareness-raising, are necessary to ensure the survival of endangered species and promote a sustainable future.

SubQuestion No : 99

Q.99 Which of the following is an example of a real-world connection to the concept of indigenous culture, as discussed in the passage?

- Ans**
- 1. The importance of preserving the cultural identity of endangered species
 - 2. The role of endangered species in maintaining the balance of the ecosystem
 - 3. The use of genetic material from endangered species to develop new medicines
 - 4. The economic benefits of ecotourism in areas with endangered species

Question ID : 264330168456

Option 1 ID : 264330660671

Option 2 ID : 264330660674

Option 3 ID : 264330660673

Option 4 ID : 264330660672

Status : Not Answered

Chosen Option : --

Comprehension:

Read the given passage and answer the questions that follow.

Endangered species are those that are at risk of becoming extinct due to various factors such as habitat destruction, poaching, pollution and climate change. The loss of biodiversity and the extinction of species are major environmental concerns, as they can have a ripple effect on the entire ecosystem. Endangered species are important to protect as they play vital roles in maintaining the balance of the ecosystem and contribute to the health and well-being of the planet and its inhabitants.

The importance of conserving endangered species is multifaceted. First and foremost, the loss of biodiversity can have a profound impact on the environment. Every species has a unique role to play in the ecosystem, and their disappearance can trigger a domino effect that can ultimately lead to ecosystem collapse. For example, pollinators such as bees and butterflies play a critical role in maintaining the health and productivity of plant communities. Without them, many plants would not be able to reproduce, and the animals that rely on those plants for food and habitat would also suffer. Similarly, predators such as wolves and lions help to regulate prey populations and prevent overgrazing, which can have negative impacts on the environment.

Endangered species also have cultural and economic value. Many indigenous cultures have close relationships with endangered species and consider them to be an integral part of their heritage and identity. For example, the Maasai people of Kenya have a strong cultural connection to elephants and consider them to be sacred animals. In addition, endangered species can be important sources of income for local communities through ecotourism. For example, the mountain gorillas of Rwanda and Uganda are a major draw for tourists, generating significant revenue for local economies.

Furthermore, endangered species can also have scientific and medical value. Many species contain unique genetic material that can be used to develop new medicines and treatments for a variety of diseases. For example, the rosy periwinkle, a plant species found only in Madagascar, produces two drugs that are used to treat certain types of cancer. In addition, endangered species can serve as indicators of environmental health. Changes in the populations of certain species can indicate changes in the quality of the environment, alerting scientists to potential issues that may require attention.

Conservation efforts are essential to protecting endangered species and preserving biodiversity. These efforts can take many forms, such as habitat restoration, anti-poaching measures and captive breeding programmes. Habitat restoration involves identifying and protecting critical habitats for endangered species and restoring degraded areas to their natural state. Anti-poaching measures are necessary to prevent the illegal hunting and trafficking of endangered species. Captive breeding programmes are used to breed and raise endangered species in captivity with the goal of releasing them into the wild. While these efforts can be costly and time-consuming, they are necessary to ensure the survival of endangered species.

Another key aspect of conservation is education and awareness-raising. Many people are unaware of the threats facing endangered species and the importance of biodiversity. Educating the public and raising awareness can help to promote greater appreciation for the natural world and inspire action to protect it. Additionally, outreach programmes can work with local communities to promote sustainable practices and reduce the impact of human activities on the environment.

In conclusion, the conservation of endangered species is a critical issue that affects the health and well-being of the planet and its inhabitants. Protecting biodiversity is important for maintaining the balance of the ecosystem, preserving cultural and economic value and advancing scientific and medical research. Conservation efforts, including habitat restoration, anti-poaching measures, captive breeding programmes and education and awareness-raising, are necessary to ensure the survival of endangered species and promote a sustainable future.

SubQuestion No : 100

Q.100 Which of the following could be an appropriate title for the given passage?

- Ans
- 1. The Importance of Biodiversity and its Conservation
 - 2. The Impact of Climate Change on the Environment
 - 3. The Role of Endangered Species in the Ecosystem
 - 4. The Benefits of Ecotourism for Local Communities

Question ID : 264330168455

Option 1 ID : 264330660667

Option 2 ID : 264330660669

Option 3 ID : 264330660668

Option 4 ID : 264330660670

Status : Not Answered

Chosen Option : --

Stenographer Grade C and D Examination 2023

Roll Number	
Candidate Name	
Venue Name	Titiksha public school
Exam Date	13/10/2023
Exam Time	4:30 PM - 6:30 PM
Subject	Stenographer Grade C and D Examination 2023

Section : General Intelligence and Reasoning

Q.1 सात मित्र, A, B, C, D, E, F और G एक सीधी पंक्ति में समान दिशा की ओर मुख करके बैठे हुए हैं। E पंक्ति के किसी एक छोर पर बैठा है। E, C के बाएं दूसरे स्थान पर बैठा है। B, C और A के बीच में बैठा है, जबकि G और A किसी भी छोर पर नहीं बैठे हैं। F, D के दाएं ठीक बगल में बैठा हुआ है। पंक्ति के ठीक मध्य में कौन बैठा है?

- Ans
- 1. G
 - 2. C
 - 3. D
 - 4. B

Question ID : 26433085697
 Option 1 ID : 264330336489
 Option 2 ID : 264330336492
 Option 3 ID : 264330336491
 Option 4 ID : 264330336490
 Status : Answered
 Chosen Option : 4

Q.2 निम्नलिखित शब्दों को तार्किक और अर्थपूर्ण क्रम में दर्शाने वाले सही विकल्प का चयन करें।

1. शब्द
2. पैराग्राफ
3. वाक्य
4. अक्षर

- Ans
- 1. 1, 3, 4, 2
 - 2. 4, 3, 1, 2
 - 3. 4, 1, 3, 2
 - 4. 1, 4, 3, 2

Question ID : 264330132913
 Option 1 ID : 264330520713
 Option 2 ID : 264330520711
 Option 3 ID : 264330520714
 Option 4 ID : 264330520712
 Status : Answered
 Chosen Option : 3

Q.3 28 जनवरी 2002 को सप्ताह का कौन-सा दिन था?

- Ans
- ✓ 1. सोमवार
 - ✗ 2. मंगलवार
 - ✗ 3. बुधवार
 - ✗ 4. रविवार

Question ID : 264330144946

Option 1 ID : 264330568040

Option 2 ID : 264330568041

Option 3 ID : 264330568042

Option 4 ID : 264330568039

Status : Answered

Chosen Option : 1

Q.4 एक निश्चित कूट भाषा में 'BROADLY' को '77' और 'FRANTIC' को '71' लिखा जाता है। उसी भाषा में 'CRUMBLE' को किस प्रकार से लिखा जाएगा?

- Ans
- ✗ 1. 76
 - ✗ 2. 72
 - ✗ 3. 75
 - ✓ 4. 74

Question ID : 26433082635

Option 1 ID : 264330324374

Option 2 ID : 264330324376

Option 3 ID : 264330324373

Option 4 ID : 264330324375

Status : Answered

Chosen Option : 4

Q.5 उस विकल्प का चयन कीजिए, जो उन अक्षरों को निरूपित करता है, जिन्हें निम्न रिक्त स्थानों में बाएँ से दाएँ रखे जाने पर, वे अक्षर श्रृंखला को पूरा कर देंगे।

AC _ GI _ C _ GIA _ EGIACE _ I _ CE _ I

- Ans
- ✗ 1. AECEGGA
 - ✗ 2. EEAEAAG
 - ✓ 3. EAECGAG
 - ✗ 4. AAEGGEA

Question ID : 264330144904

Option 1 ID : 264330567871

Option 2 ID : 264330567873

Option 3 ID : 264330567872

Option 4 ID : 264330567874

Status : Answered

Chosen Option : 3

Q.6 उस विकल्प आकृति का चयन करें जिसमें दी गई आकृति सन्निहित है (घुमाने की अनुमति नहीं है)।



Ans

✗ 1.

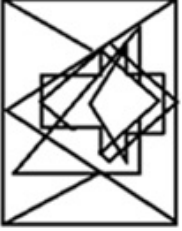

✗ 2.

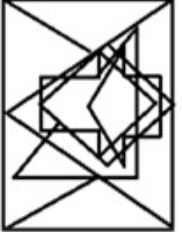

✓ 3.

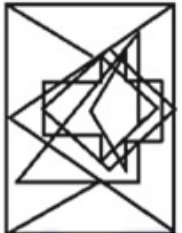

✗ 4.

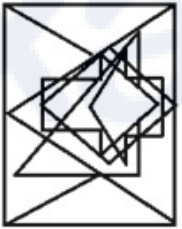

Question ID : 264330132272

Option 1 ID : 264330518184

Option 2 ID : 264330518185

Option 3 ID : 264330518186

Option 4 ID : 264330518183

Status : Answered

Chosen Option : 2

Q.7 निम्नलिखित में से कौन-सी संख्या, दी गई श्रृंखला में प्रश्नचिह्न (?) को प्रतिस्थापित करेगी?
98, 105, 52.5, 59.5, ?, 36.75

Ans ✓ 1. 29.75

✗ 2. 31.65

✗ 3. 32.69

✗ 4. 23.67

Question ID : 264330102160

Option 1 ID : 264330401105

Option 2 ID : 264330401106

Option 3 ID : 264330401107

Option 4 ID : 264330401108

Status : Answered

Chosen Option : 1

Q.8 निम्नांकित श्रृंखला में पैटर्न को जारी रखने के लिए प्रश्नचिह्न (?) को किस आकृति द्वारा प्रतिस्थापित किया जाना चाहिए?

Δ	\uparrow	=	6	6	=	V	Δ					
X	=	V	V	\uparrow	X	X	V	\uparrow	\uparrow	=	X	?
B	6	Δ			B	B	Δ	6			B	

Ans

✓ 1.

Δ	V
X	\uparrow =
B	6

✗ 2.

Δ	B
=	X \uparrow
V	6

✗ 3.

6	B
V	= Δ
\uparrow	X

✗ 4.

B	6
X	\uparrow =
Δ	V

Question ID : 264330129602

Option 1 ID : 264330507775

Option 2 ID : 264330507774

Option 3 ID : 264330507776

Option 4 ID : 264330507777

Status : Answered

Chosen Option : 1

Q.9 उस विकल्प का चयन कीजिए जो चौथी संख्या से उसी प्रकार संबंधित है जिस प्रकार पहली संख्या दूसरी संख्या से संबंधित है और पांचवीं संख्या छठी संख्या से संबंधित है?

195 : 14 :: ? : 18 :: 8 : 3

Ans ✗ 1. 319

✗ 2. 318

✗ 3. 324

✓ 4. 323

Question ID : 264330144878

Option 1 ID : 264330567770

Option 2 ID : 264330567767

Option 3 ID : 264330567769

Option 4 ID : 264330567768

Status : Answered

Chosen Option : 4

Q.10 तीन कथनों के बाद दो निष्कर्ष I और II दिए गए हैं। कथनों को सत्य मानते हुए, भले ही वे सामान्य रूप से ज्ञात तथ्यों से भिन्न प्रतीत होते हों, निर्णय लीजिए कि कौन-सा/से निष्कर्ष कथनों का तार्किक रूप से अनुसरण करता है/करते हैं।

कथन:

कोई कौवा, बंदर नहीं है।

सभी बंदर, कछुए हैं।

कोई कछुआ, घोघा नहीं है।

निष्कर्ष:

I. कुछ घोघे के कौवे होने की संभावना है।

II. कोई कछुआ, कौवा नहीं है।

- Ans
- 1. निष्कर्ष I और II दोनों अनुसरण करते हैं
 - 2. न तो निष्कर्ष I और न ही II अनुसरण करता है
 - 3. या तो निष्कर्ष I अनुसरण करता है या II अनुसरण करता है
 - 4. केवल निष्कर्ष I अनुसरण करता है

Question ID : 26433081299

Option 1 ID : 264330319041

Option 2 ID : 264330319043

Option 3 ID : 264330319044

Option 4 ID : 264330319042

Status : Answered

Chosen Option : 3

Q.11 Select the option that is related to the third word in the same way as the second word is related to the first word. (The words must be considered as meaningful English words and must not be related to each other based on the number of letters/number of consonants/vowels in the word.)

Editor : Article :: Choreographer : ?

- Ans
- 1. Design
 - 2. Dance
 - 3. Gallery
 - 4. Film

Question ID : 26433069586

Option 1 ID : 264330272857

Option 2 ID : 264330272856

Option 3 ID : 264330272859

Option 4 ID : 264330272858

Status : Answered

Chosen Option : 4

Q.12 निम्नलिखित में से उस समुच्चय का चयन कीजिए, जिसमें संख्याएँ उसी प्रकार से संबंधित हैं, जिस प्रकार दिए गए समुच्चय की संख्याएँ संबंधित हैं।

(नोट: संख्याओं को उसके घटक अंकों में विभाजित किए बिना, पूर्ण संख्याओं पर ही गणितीय संक्रियाएँ की जानी चाहिए। जैसे 13 - मान लीजिए 13 पर गणितीय संक्रियाएँ जैसे कि 13 में जोड़ना/घटाना/गुणा करना आदि किया जा सकता है। 13 को 1 और 3 में तोड़कर और फिर 1 और 3 पर गणितीय संक्रियाएँ करने की अनुमति नहीं है।)

(605, 110, 11)

(660, 40, 33)

- Ans
- 1. (720, 120, 12)
 - 2. (519, 222, 11)
 - 3. (612, 180, 13)
 - 4. (711, 188, 16)

Question ID : 26433083121

Option 1 ID : 264330326318

Option 2 ID : 264330326317

Option 3 ID : 264330326319

Option 4 ID : 264330326320

Status : Answered

Chosen Option : 1

Q.13 दिए गए विकल्पों में से उस संख्या का चयन कीजिए जो निम्नलिखित श्रृंखला में प्रश्न चिह्न (?) के स्थान पर आ सकती है।
31, 38, 47, 58, 71, ?

- Ans
- 1. 88
 - 2. 87
 - 3. 85
 - 4. 86

Question ID : 264330112659
Option 1 ID : 264330442724
Option 2 ID : 264330442723
Option 3 ID : 264330442721
Option 4 ID : 264330442722
Status : Answered
Chosen Option : 4

Q.14 निम्नलिखित में से कौन-सा पद दी गई श्रृंखला में प्रश्न-चिह्न (?) को प्रतिस्थापित करेगा?
ABC, ZYX, BCD, YXW, CDE, ?

- Ans
- 1. VTU
 - 2. VHY
 - 3. XTU
 - 4. XWV

Question ID : 26433090156
Option 1 ID : 264330354104
Option 2 ID : 264330354102
Option 3 ID : 264330354101
Option 4 ID : 264330354103
Status : Answered
Chosen Option : 4

Q.15 'A + B' का अर्थ है 'A, B का भाई है'
'A - B' का अर्थ है 'A, B की माँ है'
'A × B' का अर्थ है 'A, B का पति है'
'A ÷ B' का अर्थ है 'A, B की बहन है'
'A # B' का अर्थ है 'A, B की बहू है'
यदि 'C - M + S + K × R # T' है, तो निम्नलिखित में से कौन-सा कथन सही नहीं है?

- Ans
- 1. S, C का पोता है।
 - 2. K और M भाई हैं।
 - 3. T, S का पिता है।
 - 4. R, M के भाई की पत्नी है।

Question ID : 264330102484
Option 1 ID : 264330402366
Option 2 ID : 264330402368
Option 3 ID : 264330402365
Option 4 ID : 264330402367
Status : Answered
Chosen Option : 1

Q.16 उस विकल्प का चयन करें जो तीसरे शब्द से उसी प्रकार संबंधित है जिस प्रकार दूसरा शब्द पहले शब्द से संबंधित है।
हंसशावक : हंस :: अश्वशावक : ?

- Ans
- 1. भालू
 - 2. बारहसिंगा
 - 3. भेड़
 - 4. घोड़ा

Question ID : 26433082755
Option 1 ID : 264330324853
Option 2 ID : 264330324856
Option 3 ID : 264330324855
Option 4 ID : 264330324854
Status : Answered
Chosen Option : 4

Q.17 दिए गए समीकरण को संतुलित करने के लिए किन दो चिह्नों को आपस में बदला जाना चाहिए?
 $396 \div 2 \times 4 - 217 + 74 = 935$

- Ans
- 1. + और +
 - 2. - और +
 - 3. + और ×
 - 4. + और -

Question ID : 264330132496
Option 1 ID : 264330519079
Option 2 ID : 264330519081
Option 3 ID : 264330519082
Option 4 ID : 264330519080
Status : Answered
Chosen Option : 2

Q.18 उस विकल्प का चयन करें, जो छठी संख्या से उसी प्रकार संबंधित है, जिस प्रकार पहली संख्या दूसरी संख्या से और तीसरी संख्या चौथी संख्या से संबंधित है।
11 : 256 :: 14 : 361 :: ? : 1024

- Ans
- 1. 25
 - 2. 12
 - 3. 18
 - 4. 27

Question ID : 26433087203
Option 1 ID : 264330342451
Option 2 ID : 264330342449
Option 3 ID : 264330342450
Option 4 ID : 264330342452
Status : Answered
Chosen Option : 4

Q.19 दस व्यक्ति दो समानांतर पंक्तियों में बैठे हैं, जहाँ प्रत्येक में 5 व्यक्ति इस प्रकार हैं कि अगल-बगल के व्यक्तियों के बीच समान दूरी है।
पंक्ति 1 में – A, B, C, D और E बैठे हैं और उन सभी का मुख उत्तर की ओर है।
पंक्ति 2 में – P, Q, R, S और T बैठे हैं और उन सभी का मुख दक्षिण की ओर है।
इस प्रकार प्रत्येक व्यक्ति दूसरी पंक्ति के किसी एक व्यक्ति की ओर अभिमुख है।
न तो A पंक्ति के किसी भी अंतिम छोर पर बैठा है और न ही D। A, D के ठीक दाएँ बैठा है। P का मुख उस व्यक्ति की ओर है, जो D के दाएँ से दूसरे स्थान पर बैठा है। P और Q के बीच केवल दो व्यक्ति बैठे हैं। C, E के ठीक दाएँ बैठा है। B का मुख उस व्यक्ति की ओर है, जो R के दाएँ से दूसरे स्थान पर बैठा है। S, T के दाएँ से किसी एक स्थान पर बैठा है।
T की ओर कौन अभिमुख है?

- Ans
- 1. E
 - 2. A
 - 3. B
 - 4. C

Question ID : 264330131653
Option 1 ID : 264330515712
Option 2 ID : 264330515711
Option 3 ID : 264330515714
Option 4 ID : 264330515713
Status : Answered
Chosen Option : 4

Q.20 निम्नलिखित चार अक्षर-समूहों में से तीन एक निश्चित तरीके से आपस में संगत है, जबकि कोई एक उनसे असंगत है। असंगत अक्षर-समूह का चयन करें।

- Ans
- 1. WEBG
 - 2. DLJM
 - 3. AIFK
 - 4. FNKP

Question ID : 26433057227
Option 1 ID : 264330223894
Option 2 ID : 264330223895
Option 3 ID : 264330223893
Option 4 ID : 264330223892
Status : Answered
Chosen Option : 2

Q.21 यदि '+' का अर्थ '-', '-' का अर्थ 'x', 'x' का अर्थ '+', 'x' का अर्थ '-' है, तो निम्नलिखित व्यंजक का मान ज्ञात करें।

$$18 - 20 + 162 \times 9 \div 19 = ?$$

- Ans
- 1. 281
 - 2. 361
 - 3. 224
 - 4. 323

Question ID : 264330130350
Option 1 ID : 264330510511
Option 2 ID : 264330510512
Option 3 ID : 264330510513
Option 4 ID : 264330510514
Status : Answered
Chosen Option : 2

Q.22 यदि $A = B > C = D$ और $F < E = D < A$ है, तो निम्नलिखित में से कौन-सा विकल्प सही नहीं है?

- Ans
- 1. $F < C$
 - 2. $C = E$
 - 3. $D > F$
 - 4. $A < D$

Question ID : 26433097271

Option 1 ID : 264330381781

Option 2 ID : 264330381784

Option 3 ID : 264330381782

Option 4 ID : 264330381783

Status : Answered

Chosen Option : 1

Q.23 निम्नांकित श्रृंखला में पैटर्न को जारी रखने के लिए प्रश्नचिह्न (?) को किस आकृति द्वारा प्रतिस्थापित किया जाना चाहिए?

↑	O	△	C	
X △ L P	↑ X	↑ X P O	△ ↑	?
P	△	O	X	

Ans

1.

X		
↑	C	O
△		

2.

X		
△	↑	O
	C	

3.

↑		
C	△	X
	O	

4.

↑		
X	C	△
	O	

Question ID : 264330129605

Option 1 ID : 264330507786

Option 2 ID : 264330507787

Option 3 ID : 264330507789

Option 4 ID : 264330507788

Status : Answered

Chosen Option : 1

Q.24 दो कथनों के बाद दो निष्कर्ष I और II दिए गए हैं। कथनों को सत्य मानते हुए, भले ही वे सामान्य रूप से ज्ञात तथ्यों से भिन्न प्रतीत होते हों, निर्णय लीजिए कि कौन सा/से निष्कर्ष कथनों का तार्किक रूप से अनुसरण करता/करते है/हैं।

कथन:

सभी चाबियाँ, ताले हैं।

सभी ताले, हैंडल हैं।

निष्कर्ष:

I. कुछ ताले, चाबियाँ हैं।

II. सभी हैंडल, चाबियाँ हैं।

- Ans
- 1. केवल निष्कर्ष II अनुसरण करता है
 - 2. निष्कर्ष I और II दोनों अनुसरण करते हैं
 - 3. केवल निष्कर्ष I अनुसरण करता है
 - 4. न तो निष्कर्ष I अनुसरण करता है और न ही II अनुसरण करता है

Question ID : 264330144958

Option 1 ID : 264330568088

Option 2 ID : 264330568089

Option 3 ID : 264330568087

Option 4 ID : 264330568090

Status : Answered

Chosen Option : 3

Q.25 उस विकल्प का चयन करें जिसमें दी गई आकृति अंतर्निहित है (घुमाने की अनुमति नहीं है)।

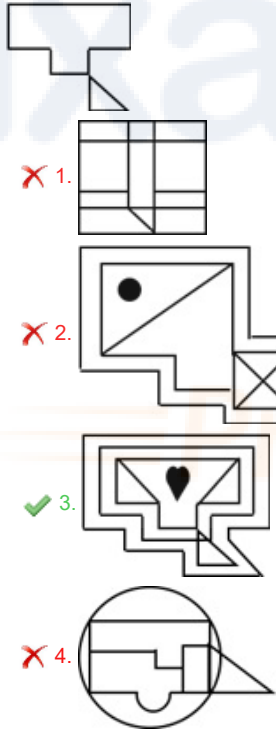

Question ID : 264330111658

Option 1 ID : 264330438718

Option 2 ID : 264330438719

Option 3 ID : 264330438717

Option 4 ID : 264330438720

Status : Answered

Chosen Option : 3

Q.26 दिए गए समीकरण को संतुलित करने के लिए किन दो संख्याओं (अंकों को नहीं) को परस्पर बदलना होगा?

$$27 \times 3 - (7)^2 + 19 + (69 \div 23) \times 6 - 15 = 70$$

- Ans 1. 7 और 6
 2. 3 और 7
 3. 19 और 15
 4. 3 और 6

Question ID : 264330144855
Option 1 ID : 264330567677
Option 2 ID : 264330567675
Option 3 ID : 264330567678
Option 4 ID : 264330567676
Status : Answered
Chosen Option : 4

Q.27 उस समुच्चय का चयन कीजिए, जिसमें संख्याएँ उसी तरह से संबंधित हैं, जिस प्रकार दिए गए समुच्चय की संख्याएँ आपस में संबंधित हैं। (नोट: संख्याओं को उसके घटक अंकों में विभाजित किए बिना, पूर्ण संख्याओं पर ही गणितीय संक्रियाएँ की जानी चाहिए। जैसे 13 - मान लीजिए 13 पर गणितीय संक्रियाएँ जैसे कि 13 में जोड़ना/घटाना/गुणा करना आदि किया जा सकता है। 13 को 1 और 3 में तोड़कर और फिर 1 और 3 पर गणितीय संक्रियाएँ करने की अनुमति नहीं है।)
(4, 42, 17)
(6, 86, 37)

- Ans 1. (8, 164, 65)
 2. (7, 114, 50)
 3. (9, 180, 82)
 4. (5, 52, 26)

Question ID : 26433078961
Option 1 ID : 264330309859
Option 2 ID : 264330309857
Option 3 ID : 264330309858
Option 4 ID : 264330309856
Status : Answered
Chosen Option : 2

Q.28 दी गई आकृति में कितने त्रिभुज हैं?

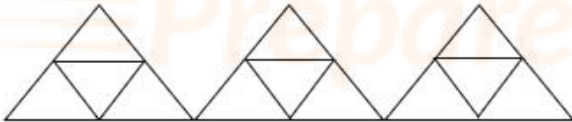

- Ans 1. 15
 2. 13
 3. 16
 4. 14

Question ID : 26433068628
Option 1 ID : 264330269024
Option 2 ID : 264330269026
Option 3 ID : 264330269027
Option 4 ID : 264330269025
Status : Answered
Chosen Option : 1

Q.29 दिए गए विकल्पों में से उस आकृति का चयन करें, जो निम्नलिखित श्रृंखला में प्रश्नचिह्न (?) को प्रतिस्थापित करेगी।

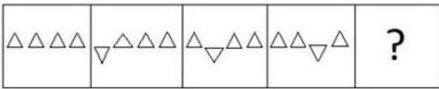

Ans

✓ 1.

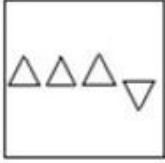

✗ 2.



✗ 3.



✗ 4.



Question ID : 26433087161
Option 1 ID : 264330342284
Option 2 ID : 264330342281
Option 3 ID : 264330342283
Option 4 ID : 264330342282
Status : Answered
Chosen Option : 1

Q.30 इंदिरा, बिंदु A से शुरू करती है, जो बिंदु B के पूर्व की ओर 7 km है। बिंदु A से, वह पूर्व की ओर 4 km दूरी तय करती है। यहाँ से, वह बाएँ मुड़ती है और 9 km दूरी तय करती है। फिर वह बाएँ मुड़ती है, 9 km दूरी तय करती है और बिंदु C पर रुक जाती है। यदि इंदिरा बिंदु C से, दक्षिण की ओर 9 km दूरी तय करती है, तो वह बिंदु B से कितनी दूर होती?

Ans ✓ 1. 2 km

✗ 2. 3 km

✗ 3. 1 km

✗ 4. 4 km

Question ID : 264330132005
Option 1 ID : 264330517117
Option 2 ID : 264330517116
Option 3 ID : 264330517118
Option 4 ID : 264330517115
Status : Answered
Chosen Option : 1

Q.31 यदि '+' का अर्थ '+', '-' का अर्थ '+', 'x' का अर्थ '-' और '+' का अर्थ 'x' है, तो निम्नलिखित समीकरण में प्रश्न चिह्न (?) के स्थान पर क्या आएगा?

$$14 - 3 \div 8 \times 63 + 9 = ?$$

- Ans 1. 33
 2. 31
 3. 50
 4. 45

Question ID : 264330101099
 Option 1 ID : 264330396943
 Option 2 ID : 264330396944
 Option 3 ID : 264330396942
 Option 4 ID : 264330396941
 Status : Answered
 Chosen Option : 2

Q.32 दिए गए विकल्पों में से उस संख्या का चयन कीजिए जो निम्नलिखित श्रृंखला में प्रश्न चिह्न (?) के स्थान पर आ सकती है।
 96, 85, 76, 69, ?

- Ans 1. 63
 2. 58
 3. 64
 4. 59

Question ID : 264330112667
 Option 1 ID : 264330442754
 Option 2 ID : 264330442753
 Option 3 ID : 264330442756
 Option 4 ID : 264330442755
 Status : Answered
 Chosen Option : 3

Q.33 उस विकल्प का चयन कीजिए जो चौथी संख्या से उसी प्रकार संबंधित है जिस प्रकार पहली संख्या दूसरी संख्या से संबंधित है और पांचवीं संख्या छठी संख्या से संबंधित है?

$$990 : 10 :: ? : 9 :: 210 : 6$$

- Ans 1. 760
 2. 712
 3. 730
 4. 720

Question ID : 264330144877
 Option 1 ID : 264330567764
 Option 2 ID : 264330567763
 Option 3 ID : 264330567766
 Option 4 ID : 264330567765
 Status : Answered
 Chosen Option : 4

Q.34 यदि 'A' का अर्थ '+' है, 'B' का अर्थ 'x' है, 'C' का अर्थ '+' है और 'D' का अर्थ '-' है, तो निम्नलिखित समीकरण में प्रश्न चिह्न (?) के स्थान पर क्या आएगा?
27 B 7 D 39 A 3 C 47 = ?

Ans ✓ 1. 223

✗ 2. 222

✗ 3. 221

✗ 4. 220

Question ID : 264330141905

Option 1 ID : 264330555942

Option 2 ID : 264330555941

Option 3 ID : 264330555940

Option 4 ID : 264330555939

Status : Answered

Chosen Option : 1

Q.35 निम्नलिखित चार अक्षर-समूहों में से तीन किसी निश्चित तरीके से आपस में संगत हैं जबकि कोई एक उनसे असंगत है। असंगत अक्षर-समूह का चयन कीजिए।

Ans ✗ 1. YADI

✗ 2. FHKP

✓ 3. TVZE

✗ 4. DFIN

Question ID : 26433057239

Option 1 ID : 264330223943

Option 2 ID : 264330223940

Option 3 ID : 264330223941

Option 4 ID : 264330223942

Status : Answered

Chosen Option : 3

Q.36 A, B, C, D, E, F और G की लंबाई भिन्न-भिन्न है। A केवल दो व्यक्तियों से छोटा है। D केवल B से लंबा है। F, A से लंबा है, लेकिन G से छोटा है। C, E से लंबा है। E से कितने लोग छोटे हैं?

Ans ✗ 1. चार

✓ 2. दो

✗ 3. पाँच

✗ 4. तीन

Question ID : 264330131656

Option 1 ID : 264330515723

Option 2 ID : 264330515725

Option 3 ID : 264330515726

Option 4 ID : 264330515724

Status : Answered

Chosen Option : 2

Q.37 एक पासे के छः फलक U, V, W, X, Y और Z हैं। उसी पासे की दो अलग-

अलग स्थितियों को दर्शाया गया है। उस अक्षर का चयन करें, जो 'V' दर्शाने वाले

फलक के विपरीत फलक पर होगा।

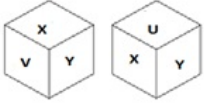

- Ans
- 1. Z
 - 2. Y
 - 3. U
 - 4. W

Question ID : 26433079521
Option 1 ID : 264330312072
Option 2 ID : 264330312075
Option 3 ID : 264330312073
Option 4 ID : 264330312074
Status : Answered
Chosen Option : 3

Q.38 दी गई श्रृंखला को पूरा करने के लिए कौन-सा अक्षर-समूह प्रश्नचिह्न (?) को प्रतिस्थापित करेगा?

BELL, CGIH, ?, EKCZ, FMZV

- Ans
- 1. DIRN
 - 2. DETM
 - 3. DEWC
 - 4. DIFD

Question ID : 264330144909
Option 1 ID : 264330567892
Option 2 ID : 264330567891
Option 3 ID : 264330567894
Option 4 ID : 264330567893
Status : Answered
Chosen Option : 4

Q.39 गुरमन ने पश्चिम की ओर 28 km झा इक्किया, फिर वह बाएं मुड़ी और 22 km झाइव किया। फिर वह दाएं मुड़ी और 18 km झा इक्किया। वह फिर दाएं मुड़ी और 22 km झाइव किया। वह एक सीधी रेखा में आरंभिक बिंदु से कितनी दूर है?

- Ans
- 1. 46 km
 - 2. 28 km
 - 3. 32 km
 - 4. 26 km

Question ID : 264330132109
Option 1 ID : 264330517531
Option 2 ID : 264330517532
Option 3 ID : 264330517534
Option 4 ID : 264330517533
Status : Answered
Chosen Option : 1

Q.40 उस विकल्प का चयन करें जिसमें दी गई आकृति अंतर्निहित है (घुमाने की अनुमति नहीं है)।

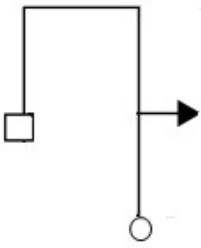

Ans

✗ 1.

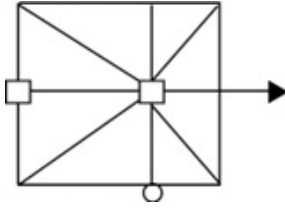

✗ 2.

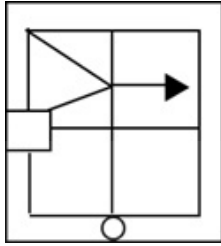

✓ 3.

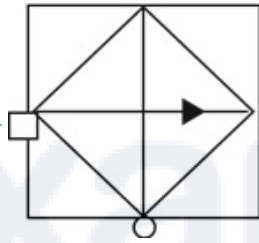

✗ 4.

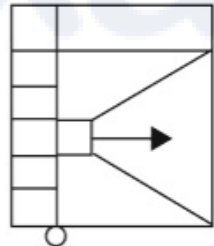

Question ID : 264330111651

Option 1 ID : 264330438691

Option 2 ID : 264330438690

Option 3 ID : 264330438689

Option 4 ID : 264330438692

Status : Answered

Chosen Option : 3

Q.41 निम्नलिखित में से कौन-सी संख्या दी गई श्रृंखला में प्रश्न चिह्न (?) को प्रतिस्थापित करेगी?
990, 891, 792, ?, 594

Ans ✗ 1. 598

✓ 2. 693

✗ 3. 614

✗ 4. 584

Question ID : 26433082432

Option 1 ID : 264330323562

Option 2 ID : 264330323561

Option 3 ID : 264330323563

Option 4 ID : 264330323564

Status : Answered

Chosen Option : 2

Q.42 निम्नलिखित में से उस समुच्चय का चयन कीजिए, जिसमें संख्याएँ उसी प्रकार से संबंधित हैं, जिस प्रकार दिए गए समुच्चय की संख्याएँ संबंधित हैं।
(नोट: संख्याओं को उसके घटक अंकों में विभाजित किए बिना, पूर्ण संख्याओं पर ही गणितीय संक्रियाएँ की जानी चाहिए। जैसे 13 - मान लीजिए 13 पर गणितीय संक्रियाएँ जैसे कि 13 में जोड़ना/घटाना/गुणा करना आदि किया जा सकता है। 13 को 1 और 3 में तोड़कर और फिर 1 और 3 पर गणितीय संक्रियाएँ करने की अनुमति नहीं है।)
(14, 98, 14)
(16, 144, 18)

- Ans
- 1. (31, 198, 16)
 - 2. (29, 122, 19)
 - 3. (24, 187, 14)
 - 4. (22, 132, 12)

Question ID : 26433083124
Option 1 ID : 264330326332
Option 2 ID : 264330326329
Option 3 ID : 264330326330
Option 4 ID : 264330326331
Status : Answered
Chosen Option : 4

Q.43 एक निश्चित कूट भाषा में 'CRUSADE' को 'ETTUZFD' लिखा जाता है और 'MUSICAL' को 'OTUHEZN' लिखा जाता है। उसी भाषा में 'AUGUST' को किस प्रकार से लिखा जाएगा?

- Ans
- 1. ZTITTU
 - 2. ZTITUV
 - 3. ZWIWUV
 - 4. ZTHTUV

Question ID : 26433082633
Option 1 ID : 264330324366
Option 2 ID : 264330324367
Option 3 ID : 264330324368
Option 4 ID : 264330324365
Status : Answered
Chosen Option : 2

Prepare 50% Faster

Q.44 एक कागज को नीचे दर्शाए गए अनुसार मोड़ा और काटा जाता है। खोलने के बाद यह कैसा दिखाई देगा?

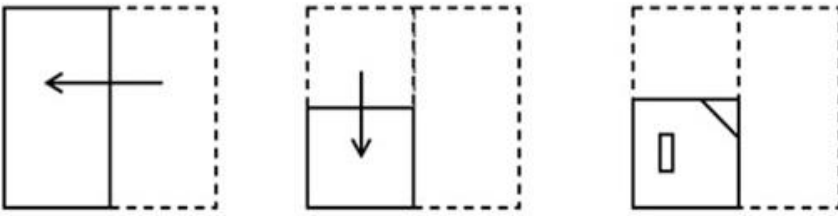

Ans

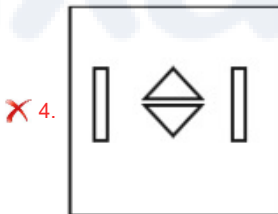
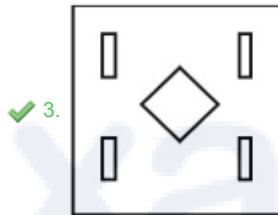
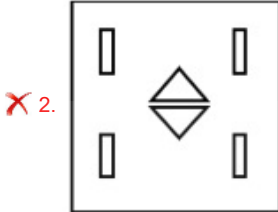
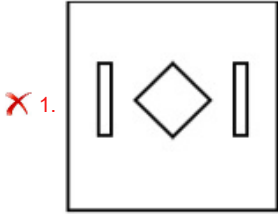

Question ID : 264330106335

Option 1 ID : 264330417642

Option 2 ID : 264330417641

Option 3 ID : 264330417644

Option 4 ID : 264330417643

Status : Answered

Chosen Option : 3

Q.45 दिए गए विकल्पों में से उस संख्या का चयन कीजिए जो निम्नलिखित श्रृंखला में प्रश्न चिह्न (?) के स्थान पर आ सकती है।

218, 231, 248, 267, ?

Ans ✓ 1. 290

✗ 2. 278

✗ 3. 286

✗ 4. 283

Question ID : 264330112671

Option 1 ID : 264330442772

Option 2 ID : 264330442769

Option 3 ID : 264330442771

Option 4 ID : 264330442770

Status : Answered

Chosen Option : 1

Q.46 एक लड़के के फोटो की ओर इशारा करते हुए लक्ष्मी ने कहा, "वह मेरे पिता की बहन के पति की पुत्री का भाई है।" फोटो वाले लड़के का लक्ष्मी से क्या संबंध है?

- Ans
- ✓ 1. फुफेरा भाई
 - ✗ 2. चाचा
 - ✗ 3. फूफा
 - ✗ 4. पिता

Question ID : 264330122624

Option 1 ID : 264330480609

Option 2 ID : 264330480608

Option 3 ID : 264330480610

Option 4 ID : 264330480607

Status : Answered

Chosen Option : 1

Q.47 उस विकल्प का चयन कीजिए जो नीचे दिए गए शब्दों के उस सही क्रम को दर्शाता है, जिस क्रम में वे अंग्रेजी शब्दकोश में आएंगे।

1. Meconium
2. Medication
3. Mediocrity
4. Mechanical
5. Meclizine
6. Mecamylamine

- Ans
- ✗ 1. 6, 5, 1, 4, 3, 2
 - ✗ 2. 6, 4, 2, 3, 5, 1
 - ✗ 3. 4, 6, 5, 1, 2, 3
 - ✓ 4. 6, 4, 5, 1, 2, 3

Question ID : 264330144934

Option 1 ID : 264330567992

Option 2 ID : 264330567993

Option 3 ID : 264330567994

Option 4 ID : 264330567991

Status : Answered

Chosen Option : 4

Q.48 तीन कथनों के बाद तीन निष्कर्ष I, II और III दिए गए हैं। कथनों को सत्य मानते हुए, भले ही वे सामान्य रूप से ज्ञात तथ्यों से भिन्न प्रतीत होते हों, निर्णय लीजिए कि कौन सा/से निष्कर्ष कथनों का तार्किक रूप से अनुसरण करता है/करते हैं।

कथन:

- कुछ बिस्तर, कुर्सियाँ हैं।
- कुछ कुर्सियाँ, मेज हैं।
- सभी मेज, अलमारी हैं।

निष्कर्ष:

- I. कुछ मेज, बिस्तर हैं।
- II. कुछ अलमारी, कुर्सियाँ हैं।
- III. कुछ अलमारी, बिस्तर हैं।

- Ans
- ✓ 1. केवल निष्कर्ष II अनुसरण करता है।
 - ✗ 2. केवल निष्कर्ष I अनुसरण करता है।
 - ✗ 3. केवल निष्कर्ष III अनुसरण करता है।
 - ✗ 4. सभी निष्कर्ष अनुसरण करते हैं।

Question ID : 26433093156

Option 1 ID : 264330365878

Option 2 ID : 264330365877

Option 3 ID : 264330365879

Option 4 ID : 264330365880

Status : Answered

Chosen Option : 1

Q.49 दिए गए समीकरण को संतुलित करने के लिए किन दो चिह्नों को आपस में बदला जाना चाहिए?

$$200 + 180 \div 12 \times 9 - 55 = 120$$

- Ans
- 1. + और +
 - 2. \times और -
 - 3. + और \times
 - 4. + और -

Question ID : 264330144853

Option 1 ID : 264330567670

Option 2 ID : 264330567669

Option 3 ID : 264330567668

Option 4 ID : 264330567667

Status : Answered

Chosen Option : 4

Q.50 दिये गये कथनों और निष्कर्षों को ध्यानपूर्वक पढ़ें। यह मानते हुए कि कथनों में दी गयी जानकारी सत्य है, भले ही वह सामान्य रूप से ज्ञात तथ्यों से भिन्न प्रतीत होती हो, निर्णय करें कि दिए गए निष्कर्षों में से कौन-सा/से निष्कर्ष कथन(नों) का तार्किक रूप से अनुसरण करता/करते है/हैं।

कथन:

कुछ छतों पलंग हैं।

कोई पलंग सेब नहीं है।

सभी कुत्ते पलंग हैं।

निष्कर्ष:

I. कुछ छतों के कुत्ते होने की संभावना है।

II. कोई कुत्ता सेब नहीं है।

III. सभी पलंग कुत्ते हैं।

IV. कोई छत सेब नहीं है।

- Ans
- 1. केवल निष्कर्ष I अनुसरण करता है
 - 2. केवल निष्कर्ष I और II अनुसरण करते हैं
 - 3. केवल निष्कर्ष II और III अनुसरण करते हैं
 - 4. केवल निष्कर्ष I, II और IV अनुसरण करते हैं

Question ID : 26433070352

Option 1 ID : 264330275886

Option 2 ID : 264330275887

Option 3 ID : 264330275884

Option 4 ID : 264330275885

Status : Answered

Chosen Option : 1

Section : General Awareness

Q.1 मलयालम नव वर्ष को केरल में क्या कहा जाता है?

- Ans
- 1. नुआखाई
 - 2. विशु
 - 3. पोंगल
 - 4. उगादी

Question ID : 26433074093

Option 1 ID : 264330290493

Option 2 ID : 264330290494

Option 3 ID : 264330290495

Option 4 ID : 264330290492

Status : Answered

Chosen Option : 2

Q.2 निम्नलिखित में से किसने आंध्र प्रदेश में विधवा पुनर्विवाह और लड़कियों की शिक्षा के समर्थन में आंदोलन का नेतृत्व किया?

- Ans 1. सी. राजगोपालाचारी
 2. कंदुकुरी वीरेशलिंगम
 3. चेम्बेटी श्रीधरालु नायडू
 4. श्री नारायण गुरु

Question ID : 264330165400

Option 1 ID : 264330648682

Option 2 ID : 264330648681

Option 3 ID : 264330648679

Option 4 ID : 264330648680

Status : Answered

Chosen Option : 3

Q.3 भारत में कार्यबल की क्षेत्रीय संरचना (2011) के आंकड़ों के अनुसार, कुल श्रमिकों का कितना प्रतिशत प्राथमिक क्षेत्र में कार्यरत है?

- Ans 1. 41.6%
 2. 58.4%
 3. 54.6%
 4. 3.8%

Question ID : 264330119924

Option 1 ID : 264330469973

Option 2 ID : 264330469974

Option 3 ID : 264330469972

Option 4 ID : 264330469971

Status : Answered

Chosen Option : 2

Q.4 हड़प्पा सभ्यता के विशाल स्नानागार से संबंधित दिए गए कथनों के आधार पर सही विकल्प का चयन कीजिए।

कथन I: विशाल स्नानागार हड़प्पा सभ्यता के मोहनजोदड़ो स्थल में पाया गया था।
कथन II: विशाल स्नानागार को ईंटों को एक निश्चित क्रम में रखते हुए बनाया गया था, प्लास्टर से लेपित किया गया था और उसे प्राकृतिक राल की एक परत से जल-रोधी बनाया गया था।

- Ans 1. केवल कथन II सत्य है।
 2. न तो कथन I सत्य है और न ही कथन II सत्य है।
 3. कथन I और कथन II दोनों सत्य हैं।
 4. केवल कथन I सत्य है।

Question ID : 264330141810

Option 1 ID : 264330555560

Option 2 ID : 264330555562

Option 3 ID : 264330555561

Option 4 ID : 264330555559

Status : Answered

Chosen Option : 3

Q.5 IOA के प्रथम अध्यक्ष कौन थे?

- Ans
- 1. एच.सी. बक
 - 2. डॉ. हेनरी ग्रे
 - 3. प्रो. जी.डी. सोंधी
 - 4. सर दोराबजी टाटा

Question ID : 264330110359

Option 1 ID : 264330433715

Option 2 ID : 264330433716

Option 3 ID : 264330433713

Option 4 ID : 264330433714

Status : Marked For Review

Chosen Option : 1

Q.6 भारतीय संविधान में राज्य के नीति निर्देशक तत्व निम्नलिखित में से किस संविधान से लिए गए हैं?

- Ans
- 1. पोलैंड के संविधान
 - 2. ब्रिटेन के संविधान
 - 3. यूएसएसआर के संविधान
 - 4. आयरलैंड के संविधान

Question ID : 264330112779

Option 1 ID : 264330443203

Option 2 ID : 264330443204

Option 3 ID : 264330443201

Option 4 ID : 264330443202

Status : Answered

Chosen Option : 4

Q.7 Which of the following is NOT true about the circular flow of income in a two-sector economy?

- Ans
- 1. Real Flow is more than money flow.
 - 2. Factor payment is equal to factor income.
 - 3. Consumption expenditure is equal to factor income.
 - 4. Total production is equal to total consumption.

Question ID : 264330106677

Option 1 ID : 264330419011

Option 2 ID : 264330419012

Option 3 ID : 264330419010

Option 4 ID : 264330419009

Status : Answered

Chosen Option : 1

Q.8 किस वर्ष के आस-पास रॉबर्ट ब्राउन (Robert Brown) ने एक लेख प्रस्तुत किया था, जिसमें पादप कोशिकाओं में केंद्रक की उपस्थिति पर प्रकाश डाला गया था?

- Ans
- 1. 1780s
 - 2. 1950s
 - 3. 1830s
 - 4. 1660s

Question ID : 264330113471

Option 1 ID : 264330445972

Option 2 ID : 264330445971

Option 3 ID : 264330445970

Option 4 ID : 264330445969

Status : Answered

Chosen Option : 4

Q.9 विषाणुओं के व्यास के आकार की सीमा _____ तक होती है।

Ans ✓ 1. 20–200 nm

✗ 2. 300-500 nm

✗ 3. 10–100 nm

✗ 4. 5–50 nm

Question ID : 264330131714

Option 1 ID : 264330515956

Option 2 ID : 264330515955

Option 3 ID : 264330515957

Option 4 ID : 264330515958

Status : Answered

Chosen Option : 3

Q.10 नमक सत्याग्रह का संबंध _____ से था।

Ans ✓ 1. सविनय अवज्ञा आंदोलन

✗ 2. खेड़ा आंदोलन

✗ 3. चंपारण सत्याग्रह

✗ 4. भारत छोड़ो आंदोलन

Question ID : 264330111399

Option 1 ID : 264330437683

Option 2 ID : 264330437684

Option 3 ID : 264330437682

Option 4 ID : 264330437681

Status : Answered

Chosen Option : 1

Q.11 बतुकम्मा महोत्सव के संबंध में निम्नलिखित में से कौन से कथन सही हैं?

A. यह त्योहार तेलंगाना राज्य में मनाया जाता है।

B. बतुकम्मा जिसका अर्थ 'देवी माँ जीवित हो जाएं' है, रंग-बिरंगे फूलों का उत्सव है।

C. यह त्योहार सितंबर या अक्टूबर के दौरान (प्रायः दशहरे से पहले) 9 दिनों तक मनाया जाता है।

D. इस त्योहार के दौरान पुरुष फूलों के गुच्छों के चारों ओर नाचते और गाते हैं।

Ans ✗ 1. A, B, C और D

✗ 2. केवल A, C और D

✓ 3. केवल A, B और C

✗ 4. केवल B, C और D

Question ID : 264330111550

Option 1 ID : 264330438285

Option 2 ID : 264330438287

Option 3 ID : 264330438286

Option 4 ID : 264330438288

Status : Answered

Chosen Option : 1

Q.12 सदिया-धुबरी खंड को जोड़ने वाला राष्ट्रीय जलमार्ग-2 निम्नलिखित में से किस नदी पर स्थित है?

- Ans 1. ब्रह्मपुत्र
 2. कृष्णा
 3. गंगा
 4. गोदावरी

Question ID : 264330163227
Option 1 ID : 264330640221
Option 2 ID : 264330640220
Option 3 ID : 264330640219
Option 4 ID : 264330640222
Status : Answered
Chosen Option : 1

Q.13 एस. बलेश भजंत्री को 2022 में पद्म श्री पुरस्कार से सम्मानित किया गया। वे _____ वादन के लिए प्रसिद्ध हैं।

- Ans 1. शहनाई
 2. बांसुरी
 3. घटम
 4. मृदंगम

Question ID : 26433064636
Option 1 ID : 264330253137
Option 2 ID : 264330253136
Option 3 ID : 264330253139
Option 4 ID : 264330253138
Status : Answered
Chosen Option : 4

Q.14 Brihat Samhita was the treatise of which of the following subjects?

- Ans 1. Natural History
 2. Astronomy
 3. Botany
 4. Geography

Question ID : 264330112142
Option 1 ID : 264330440656
Option 2 ID : 264330440655
Option 3 ID : 264330440654
Option 4 ID : 264330440653
Status : Answered
Chosen Option : 2

Q.15 ग्रेनाइट के प्रमुख घटक क्या हैं?

Ans 1. TiO_2 और ZnSO_4

2. SiO_2 और Al_2O_3

3. MnO_2 और PbSO_4

4. ZnSO_4 और Al_2O_3

Question ID : 264330111917

Option 1 ID : 264330439756

Option 2 ID : 264330439755

Option 3 ID : 264330439753

Option 4 ID : 264330439754

Status : Answered

Chosen Option : 2

Q.16 मार्च 2023 तक प्राप्त जानकारी के अनुसार, भारत के मुख्य चुनाव आयुक्त कौन हैं?

Ans 1. सुशील चंद्रा

2. राजीव कुमार

3. अनूप चंद्र पाण्डेय

4. अरुण गोयल

Question ID : 264330158511

Option 1 ID : 264330621406

Option 2 ID : 264330621405

Option 3 ID : 264330621403

Option 4 ID : 264330621404

Status : Answered

Chosen Option : 1

Q.17 निम्नलिखित में से किसे विश्व में 'हरित क्रांति का जनक' कहा जाता है?

Ans 1. लिनस पॉलिंग

2. नॉर्मन बोरलॉग

3. एम.एस. स्वामीनाथन

4. राल्फ बंचे

Question ID : 264330110177

Option 1 ID : 264330432985

Option 2 ID : 264330432987

Option 3 ID : 264330432988

Option 4 ID : 264330432986

Status : Answered

Chosen Option : 1

Q.18 रमा वैद्यनाथन को किस भारतीय शास्त्रीय नृत्य शैली के लिए अकादमी पुरस्कार प्रदान किया गया है?

- Ans 1. मणिपुरी
 2. कथक
 3. भरतनाट्यम
 4. सत्रीया

Question ID : 264330132403

Option 1 ID : 264330518707

Option 2 ID : 264330518709

Option 3 ID : 264330518710

Option 4 ID : 264330518708

Status : Answered

Chosen Option : 3

Q.19 निम्नलिखित में से किस देवता को उत्तर वैदिक काल में एक नया उपनाम 'हल का स्वामी' प्राप्त हुआ?

- Ans 1. वरुण
 2. ब्रह्मा
 3. विष्णु
 4. इंद्र

Question ID : 264330165337

Option 1 ID : 264330648427

Option 2 ID : 264330648430

Option 3 ID : 264330648429

Option 4 ID : 264330648428

Status : Answered

Chosen Option : 4

Q.20 भारत के योजना आयोग (2011-12) के अनुसार, गरीबी रेखा से नीचे की जनसंख्या के प्रतिशत के साथ निम्नलिखित राज्यों का मिलान करें।

राज्य	गरीबी रेखा से नीचे की जनसंख्या का %
1. गुजरात	a. 8.06
2. हरियाणा	b. 11.16
3. हिमाचल प्रदेश	c. 16.63

- Ans 1. 1-c, 2-b, 3-a
 2. 1-c, 2-a, 3-b
 3. 1-b, 2-c, 3-a
 4. 1-a, 2-b, 3-c

Question ID : 264330119919

Option 1 ID : 264330469952

Option 2 ID : 264330469951

Option 3 ID : 264330469953

Option 4 ID : 264330469954

Status : Answered

Chosen Option : 4

Q.21 मामलुक शैली की स्थापत्य कला किस वंश से संबंधित है?

- Ans
- ✓ 1. गुलाम वंश
 - ✗ 2. तुगलक वंश
 - ✗ 3. खिलजी वंश
 - ✗ 4. लोदी वंश

Question ID : 26433066559
 Option 1 ID : 264330260763
 Option 2 ID : 264330260762
 Option 3 ID : 264330260761
 Option 4 ID : 264330260760
 Status : Answered
 Chosen Option : 1

Q.22 ट्रा इब्रोमोएफ्रेकिस ब्रोमिनेटेड कार्बनिक विलायक का एक पर्याय है?

- Ans
- ✗ 1. डाइबोरेन
 - ✗ 2. ब्रोमो सक्सिनिमाइड
 - ✗ 3. बोरज़ीन
 - ✓ 4. ब्रोमोफॉर्म

Question ID : 264330141676
 Option 1 ID : 264330555025
 Option 2 ID : 264330555026
 Option 3 ID : 264330555023
 Option 4 ID : 264330555024
 Status : Answered
 Chosen Option : 4

Q.23 जनवरी 2023 तक प्राप्त जानकारी के अनुसार, गुजरात के/की राज्यपाल कौन हैं?

- Ans
- ✗ 1. आनंदीबेन पटेल
 - ✗ 2. बनवारीलाल पुरोहित
 - ✗ 3. भूपेंद्र पटेल
 - ✓ 4. आचार्य देवव्रत

Question ID : 264330165218
 Option 1 ID : 264330647971
 Option 2 ID : 264330647973
 Option 3 ID : 264330647974
 Option 4 ID : 264330647972
 Status : Answered
 Chosen Option : 4

Q.24 भारत में जब पहली रेलवे लाइन बिछाई गई, उस समय गवर्नर-जनरल कौन था?

- Ans
- ✗ 1. लॉर्ड विलियम बेंटिक
 - ✗ 2. लॉर्ड कार्नवालिस
 - ✗ 3. वारेन हेस्टिंग्स
 - ✓ 4. लॉर्ड डलहौजी

Question ID : 264330112190
 Option 1 ID : 264330440845
 Option 2 ID : 264330440847
 Option 3 ID : 264330440846
 Option 4 ID : 264330440848
 Status : Answered
 Chosen Option : 4

Q.25 हर्षवर्धन की मृत्यु के लगभग 75 वर्ष बाद किस शासक ने कन्नौज की सत्ता संभाली?

- Ans
- 1. यादगिरी
 - 2. यशोवर्मन
 - 3. पुलकेशिन द्वितीय
 - 4. महेन्द्रवर्मन

Question ID : 264330106596
Option 1 ID : 264330418688
Option 2 ID : 264330418686
Option 3 ID : 264330418685
Option 4 ID : 264330418687
Status : Answered
Chosen Option : 3

Q.26 हरि प्रसाद चौरसिया किस वाद्य यंत्र के उल्लेखनीय प्रतिपादक हैं?

- Ans
- 1. वीणा
 - 2. सरोद
 - 3. सितार
 - 4. बांसुरी

Question ID : 26433064253
Option 1 ID : 264330251606
Option 2 ID : 264330251604
Option 3 ID : 264330251607
Option 4 ID : 264330251605
Status : Answered
Chosen Option : 4

Q.27 केलुचरण महापात्र का संबंध निम्नलिखित में से किस नृत्य से है?

- Ans
- 1. ओडिसी
 - 2. सत्रीया
 - 3. भरतनाट्यम
 - 4. कथक

Question ID : 264330164799
Option 1 ID : 264330646326
Option 2 ID : 264330646324
Option 3 ID : 264330646325
Option 4 ID : 264330646323
Status : Answered
Chosen Option : 1

Q.28 केंद्रीय विश्वविद्यालय (संशोधन) विधेयक, 2022, _____ की स्थापना से संबंधित है।

- Ans
- 1. महात्मा गांधी केंद्रीय विश्वविद्यालय
 - 2. आंध्रप्रदेश केंद्रीय विश्वविद्यालय (CUAP)
 - 3. केंद्रीय जनजातीय विश्वविद्यालय आंध्रप्रदेश (CTUAP)
 - 4. गति शक्ति विश्वविद्यालय

Question ID : 264330158487
Option 1 ID : 264330621308
Option 2 ID : 264330621310
Option 3 ID : 264330621309
Option 4 ID : 264330621307
Status : Answered
Chosen Option : 4

Q.29 निम्नलिखित में से कौन-सी एक किसी खिलाड़ी की आत्मकथा नहीं है?

- Ans
- 1. प्लेइंग इट माई वे
 - 2. द रेस ऑफ माई लाइफ
 - 3. स्ट्रेट फ्रॉम द हार्ट
 - 4. करेज एंड कन्विकशन

Question ID : 26433072943
Option 1 ID : 264330285964
Option 2 ID : 264330285965
Option 3 ID : 264330285967
Option 4 ID : 264330285966
Status : Answered
Chosen Option : 4

Q.30 चावल की निम्नलिखित में से किस किस्म को भारत के लिए चमत्कारिक चावल के रूप में जाना जाता है और इसे पहली बार 1967 में असाधारण उपज के साथ उगाया गया था?

- Ans
- 1. DGWG
 - 2. PETA
 - 3. IR8
 - 4. IR9

Question ID : 26433064540
Option 1 ID : 264330252754
Option 2 ID : 264330252752
Option 3 ID : 264330252753
Option 4 ID : 264330252755
Status : Answered
Chosen Option : 3

Q.31 स्तंभ A में वन्यजीव अभ्यारण्यों का, स्तंभ B में उनके संबंधित राज्यों से मिलान कीजिए।

स्तंभ A (वन्यजीव अभ्यारण्य)	स्तंभ B (राज्य)
1. तानसा	a. तमिलनाडु
2. गुइंडी	b. महाराष्ट्र
3. ओरछा	c. मध्य प्रदेश
4. काजीरंगा	d. असम

- Ans
- 1. 1-a, 2-b, 3-c, 4-d
 - 2. 1-b, 2-a, 3-d, 4-c
 - 3. 1-b, 2-c, 3-a, 4-d
 - 4. 1-b, 2-a, 3-c, 4-d

Question ID : 264330167275
Option 1 ID : 264330656095
Option 2 ID : 264330656096
Option 3 ID : 264330656097
Option 4 ID : 264330656098
Status : Answered
Chosen Option : 4

Q.32 प्रायद्वीपीय भारत की सबसे बड़ी नदी कौन-सी है?

- Ans 1. गोदावरी
 2. कृष्णा
 3. तापी
 4. तुंगभद्रा

Question ID : 264330169994
 Option 1 ID : 264330666653
 Option 2 ID : 264330666651
 Option 3 ID : 264330666652
 Option 4 ID : 264330666654
 Status : Answered
 Chosen Option : 1

Q.33 भारत में वाणिज्यिक बैंकों द्वारा निम्नलिखित में से कौन-सा कार्य किया जाता है?

- Ans 1. सरकार को बैंकिंग सुविधाएं
 2. ऋण नियंत्रण
 3. मुद्रा जारी करना
 4. ऋण निर्माण

Question ID : 264330109094
 Option 1 ID : 264330428654
 Option 2 ID : 264330428653
 Option 3 ID : 264330428655
 Option 4 ID : 264330428656
 Status : Answered
 Chosen Option : 2

Q.34 टाइफाइड बुखार की उपस्थिति की पुष्टि करने के लिए निम्नलिखित में से किस परीक्षण का उपयोग किया जाता है?

- Ans 1. विवैक्स टेस्ट
 2. विडाल टेस्ट
 3. आलेप परीक्षण
 4. सी रिएक्टिव प्रोटीन (CRP) टेस्ट

Question ID : 264330131723
 Option 1 ID : 264330515994
 Option 2 ID : 264330515992
 Option 3 ID : 264330515993
 Option 4 ID : 264330515991
 Status : Answered
 Chosen Option : 2

Q.35 भारतीय संविधान के अनुसार, संयुक्त लोक सेवा आयोग के सदस्य के लिए अपने पद पर बने रहने की अधिकतम आयु क्या है?

- Ans 1. 65 वर्ष
 2. 62 वर्ष
 3. 60 वर्ष
 4. 66 वर्ष

Question ID : 264330133068
 Option 1 ID : 264330521326
 Option 2 ID : 264330521324
 Option 3 ID : 264330521323
 Option 4 ID : 264330521325
 Status : Answered
 Chosen Option : 2

Q.36 जनवरी 2023 तक प्राप्त जानकारी के अनुसार, छत्तीसगढ़ के मुख्यमंत्री कौन हैं?

- Ans
- 1. भूपेंद्र पटेल
 - 2. अशोक गहलोत
 - 3. रमन सिंह
 - 4. भूपेश बघेल

Question ID : 264330165214
Option 1 ID : 264330647958
Option 2 ID : 264330647956
Option 3 ID : 264330647957
Option 4 ID : 264330647955
Status : Answered
Chosen Option : 4

Q.37 नेताजी सुभाष राष्ट्रीय खेल संस्थान कहाँ स्थित है?

- Ans
- 1. पटियाला
 - 2. बंगलुरु
 - 3. कोलकाता
 - 4. नई दिल्ली

Question ID : 264330110365
Option 1 ID : 264330433740
Option 2 ID : 264330433739
Option 3 ID : 264330433738
Option 4 ID : 264330433737
Status : Answered
Chosen Option : 3

Q.38 निम्नलिखित धातुओं में से, आवर्त सारणी में उनके स्थान के आधार पर असंगत धातु का चयन कीजिए।

- Ans
- 1. लिथियम
 - 2. सोडियम
 - 3. पोटेशियम
 - 4. मैग्नीशियम

Question ID : 264330169295
Option 1 ID : 264330663961
Option 2 ID : 264330663960
Option 3 ID : 264330663959
Option 4 ID : 264330663962
Status : Answered
Chosen Option : 2

Q.39 उत्तर प्रदेश निम्नलिखित में से किस शास्त्रीय नृत्य शैली के लिए प्रसिद्ध है?

- Ans
- 1. कथक
 - 2. कथकली
 - 3. सत्रीया
 - 4. भरतनाट्यम

Question ID : 264330109272
Option 1 ID : 264330429366
Option 2 ID : 264330429368
Option 3 ID : 264330429367
Option 4 ID : 264330429365
Status : Answered
Chosen Option : 1

Q.40 अर्जुन पुरस्कार की शुरुआत किस वर्ष में हुई थी?

- Ans 1. 1961 में
 2. 1955 में
 3. 1951 में
 4. 1965 में

Question ID : 264330110354

Option 1 ID : 264330433695

Option 2 ID : 264330433694

Option 3 ID : 264330433693

Option 4 ID : 264330433696

Status : Not Attempted and
Marked For Review

Chosen Option : --

Q.41 निम्नलिखित में से कौन-से विकल्प में सभी संक्रमण धातुएं हैं?

- Ans 1. F, Cl, Br, I
 2. He, Ne, Ar, Au
 3. Cu, Fe, Ni, Ti
 4. Na, Mg, Al, Mn

Question ID : 264330131782

Option 1 ID : 264330516229

Option 2 ID : 264330516230

Option 3 ID : 264330516227

Option 4 ID : 264330516228

Status : Answered

Chosen Option : 3

Q.42 इंडियन आयरन एंड स्टील कंपनी ने अपना पहला कारखाना निम्नलिखित में से किस स्थान पर स्थापित किया था?

- Ans 1. हरिपुर
 2. रानीगंज
 3. दामोदर
 4. हीरापुर

Question ID : 264330163212

Option 1 ID : 264330640159

Option 2 ID : 264330640162

Option 3 ID : 264330640160

Option 4 ID : 264330640161

Status : Not Attempted and
Marked For Review

Chosen Option : --

Q.43 जीवाण्वीय कशाभ (फ्लेजिला) के कितने घटक होते हैं?

Ans 1. 3

2. 1

3. 2

4. 4

Question ID : 264330111555

Option 1 ID : 264330438307

Option 2 ID : 264330438305

Option 3 ID : 264330438306

Option 4 ID : 264330438308

Status : Not Attempted and
Marked For Review

Chosen Option : --

Q.44 फुटबॉल के गोल पोस्टों के बीच की दूरी कितनी होती है?

Ans 1. 8.34 m

2. 7.32 m

3. 6.32 m

4. 7.10 m

Question ID : 264330119286

Option 1 ID : 264330467434

Option 2 ID : 264330467432

Option 3 ID : 264330467431

Option 4 ID : 264330467433

Status : Not Attempted and
Marked For Review

Chosen Option : --

Q.45 कौन सा पारिस्थितिक नियम कहता है कि गर्म जलवायु में शरीर का रूप या आकार रैखिक होता है और ठंडी जलवायु में अधिक गोल और सुगठित होता है?

Ans 1. जॉर्डन का नियम (Jordon's rule)

2. एलन का नियम (Allen's rule)

3. योदा का नियम (Yoda's rule)

4. ग्लोडर का नियम (Gloder's rule)

Question ID : 264330113480

Option 1 ID : 264330446006

Option 2 ID : 264330446008

Option 3 ID : 264330446007

Option 4 ID : 264330446005

Status : Not Attempted and
Marked For Review

Chosen Option : --

Q.46 कथकली का गायन प्रदर्शन पारंपरिक रूप से _____ में किया जाता है।

Ans 1. मराठी

2. संस्कृतनिष्ठ मलयालम

3. संस्कृतनिष्ठ तमिल

4. हिन्दी

Question ID : 264330109267

Option 1 ID : 264330429345

Option 2 ID : 264330429347

Option 3 ID : 264330429348

Option 4 ID : 264330429346

Status : Answered

Chosen Option : 2

Q.47 पंजाब में बहने वाली पांच नदियों; सतलुज, ब्यास, रावी, चिनाब और झेलम को 'पंचनद' नाम दिया गया है। ये नदियां अंततः किस सागर में गिरती हैं?

Ans 1. कैस्पियन सागर

2. अरब सागर

3. अंडमान सागर

4. लाल सागर

Question ID : 264330114605

Option 1 ID : 264330450508

Option 2 ID : 264330450507

Option 3 ID : 264330450506

Option 4 ID : 264330450505

Status : Answered

Chosen Option : 2

Q.48 'हैरी पॉटर एंड द प्रिजनर ऑफ अज़काबान' के लेखक कौन हैं?

Ans 1. सलमान रुश्दी

2. जॉर्ज एलियट

3. जे.के. रॉउलिंग

4. स्टीफन किंग

Question ID : 264330144845

Option 1 ID : 264330567635

Option 2 ID : 264330567638

Option 3 ID : 264330567637

Option 4 ID : 264330567636

Status : Answered

Chosen Option : 3

Q.49 ओवल स्टेडियम का संबंध किस खेल से है?

Ans 1. बास्केटबॉल

2. फुटबॉल

3. हॉकी

4. क्रिकेट

Question ID : 264330110386

Option 1 ID : 264330433821

Option 2 ID : 264330433823

Option 3 ID : 264330433822

Option 4 ID : 264330433824

Status : Not Attempted and Marked For Review

Chosen Option : --

Q.50 जनगणना-2011 के अनुसार, भारत की औसत वार्षिक वृद्धि दर क्या है?

Ans 1. 1.64%

2. 1.95%

3. 1.56%

4. 1.46%

Question ID : 264330166813

Option 1 ID : 264330654288

Option 2 ID : 264330654287

Option 3 ID : 264330654290

Option 4 ID : 264330654289

Status : Answered

Chosen Option : 1

Section : English Language and Comprehension

Q.1 The following sentence has been split into four segments. Identify the segment that contains a grammatical error.

You can have accused / me of being lazy, / but I will not finish / the project right now.

Ans 1. the project right now

2. but I will not finish

3. me of being lazy,

4. You can have accused

Question ID : 264330133409

Option 1 ID : 264330522670

Option 2 ID : 264330522669

Option 3 ID : 264330522668

Option 4 ID : 264330522667

Status : Answered

Chosen Option : 4

Q.2 Select the option that expresses the following sentence in active voice.

A delicious meal was prepared by the chef.

Ans 1. The chef has prepared a delicious meal.

2. The chef has been preparing a delicious meal.

3. The chef had prepared a delicious meal.

4. The chef prepared a delicious meal.

Question ID : 264330168112

Option 1 ID : 264330659327

Option 2 ID : 264330659330

Option 3 ID : 264330659329

Option 4 ID : 264330659328

Status : Answered

Chosen Option : 4

Q.3 Select the most appropriate ANTONYM of the given word.
General

- Ans 1. Specific
 2. Common
 3. Composite
 4. Mixture

Question ID : 264330168298
Option 1 ID : 264330660055
Option 2 ID : 264330660058
Option 3 ID : 264330660056
Option 4 ID : 264330660057
Status : Answered
Chosen Option : 1

Q.4 Select the option that expresses the given sentence in indirect speech.
She said, "I am going to the library to return the book".

- Ans 1. She said that she was going to the library to return the book.
 2. She said that she had gone to the library to return the book.
 3. She said that she will go to the library to return the book.
 4. She said that she is going to the library to return the book.

Question ID : 264330139230
Option 1 ID : 264330545457
Option 2 ID : 264330545458
Option 3 ID : 264330545455
Option 4 ID : 264330545456
Status : Answered
Chosen Option : 1

Q.5 Select the most appropriate option that can substitute the underlined segment in the given sentence.
The fluffy cat used to make a feeble cry by the others only which food was supplied by Leepika.

- Ans 1. about the others while food
 2. over the others when food
 3. among the others what food
 4. above the others where food

Question ID : 264330117216
Option 1 ID : 264330460925
Option 2 ID : 264330460928
Option 3 ID : 264330460926
Option 4 ID : 264330460927
Status : Marked For Review
Chosen Option : 2

Q.6 Select the most appropriate meaning of the underlined idiom in the following sentence.

Qualifying for JEE Advanced has given Abhikriti a shot in the arm.

- Ans
- 1. A dose of medication
 - 2. A boost or stimulant
 - 3. A trivial annoyance
 - 4. Put in trouble

Question ID : 264330168143

Option 1 ID : 264330659447

Option 2 ID : 264330659448

Option 3 ID : 264330659450

Option 4 ID : 264330659449

Status : Answered

Chosen Option : 2

Q.7 Select the most appropriate synonym of the underlined word in the following sentence.

The artist skilfully captured the intricate contours of the mountain range.

- Ans
- 1. Reasonable
 - 2. Complex
 - 3. Systematic
 - 4. Fantastic

Question ID : 264330168124

Option 1 ID : 264330659376

Option 2 ID : 264330659378

Option 3 ID : 264330659377

Option 4 ID : 264330659375

Status : Answered

Chosen Option : 2

Q.8 Select the most appropriate option that can substitute the underlined segment in the given sentence.

Many Cubans in circumstances similar to what I had become American citizens at the first opportunity.

- Ans
- 1. like those of mine
 - 2. similar to mine
 - 3. like that of mine
 - 4. similar to what I have

Question ID : 264330120589

Option 1 ID : 264330472601

Option 2 ID : 264330472599

Option 3 ID : 264330472602

Option 4 ID : 264330472600

Status : Answered

Chosen Option : 4

Q.9 Select the most appropriate option to fill in the blank.

There was utter _____ after the explosion.

- Ans 1. pacifism
 2. mayhem
 3. force
 4. belting

Question ID : 264330169987

Option 1 ID : 264330666626

Option 2 ID : 264330666623

Option 3 ID : 264330666624

Option 4 ID : 264330666625

Status : Marked For Review

Chosen Option : 4

Q.10 Select the option that can be used as a one-word substitute for the underlined words.
Whatever topic I discussed with the sage, it seemed that he knew everything.

- Ans 1. was a psychologist
 2. was omniscient
 3. was abnormal
 4. was excellent

Question ID : 264330131574

Option 1 ID : 264330515401

Option 2 ID : 264330515399

Option 3 ID : 264330515402

Option 4 ID : 264330515400

Status : Answered

Chosen Option : 2

Q.11 Select the most appropriate option to fill in the blank.

Panna in Madhya Pradesh is the diamond mining capital of India, and fortune-seekers have been _____ the territory for years in pursuit of the precious stones.

- Ans 1. abandoning
 2. scouring
 3. ignoring
 4. neglecting

Question ID : 26433098921

Option 1 ID : 264330388337

Option 2 ID : 264330388339

Option 3 ID : 264330388340

Option 4 ID : 264330388338

Status : Answered

Chosen Option : 2

Q.12 The following sentence has been split into four segments. Identify the segment that contains a grammatical error.

Ramya, Soumya's sister, / always tells / Kiran that / she will helped him.

- Ans
- 1. she will helped him
 - 2. Kiran that
 - 3. Ramya, Soumya's sister,
 - 4. always tells

Question ID : 264330139155

Option 1 ID : 264330545198

Option 2 ID : 264330545197

Option 3 ID : 264330545195

Option 4 ID : 264330545196

Status : Answered

Chosen Option : 1

Q.13 The following sentence has been split into four segments. Identify the segment that contains a grammatical error.

Nothing hinders the cat / from reaching its master / whenever it listening / to his voice.

- Ans
- 1. to his voice
 - 2. whenever it listening
 - 3. Nothing hinders the cat
 - 4. from reaching its master

Question ID : 26433099908

Option 1 ID : 264330392224

Option 2 ID : 264330392223

Option 3 ID : 264330392221

Option 4 ID : 264330392222

Status : Answered

Chosen Option : 2

Q.14 Select the option that expresses the given sentence in indirect speech.

"I have been to Hyderabad", Vishnu told me.

- Ans
- 1. Vishnu tell me that he has been to Hyderabad.
 - 2. Vishnu told me that he have be to Hyderabad.
 - 3. Vishnu told me that he had been to Hyderabad.
 - 4. Vishnu told me that he has being to Hyderabad.

Question ID : 264330140603

Option 1 ID : 264330550766

Option 2 ID : 264330550765

Option 3 ID : 264330550763

Option 4 ID : 264330550764

Status : Answered

Chosen Option : 3

Q.15 Select the most appropriate option to fill in the blank.

Asanas, or yoga postures, primarily serve as a lubrication practice for the body's joints, muscles, ligaments, and other parts, _____ circulation and flexibility.

- Ans
- 1. dwindling
 - 2. retrenching
 - 3. boosting
 - 4. abating

Question ID : 26433098924
Option 1 ID : 264330388349
Option 2 ID : 264330388352
Option 3 ID : 264330388351
Option 4 ID : 264330388350
Status : Answered
Chosen Option : 3

Q.16 Select the most appropriate synonym of the given word.
Jubilant

- Ans
- 1. Stunted
 - 2. Overjoyed
 - 3. Journeyed
 - 4. Terrified

Question ID : 264330164269
Option 1 ID : 264330644302
Option 2 ID : 264330644300
Option 3 ID : 264330644299
Option 4 ID : 264330644301
Status : Answered
Chosen Option : 2

Q.17 Select the option that expresses the given sentence in direct speech.
Parvathy explained that she was playing the violin.

- Ans
- 1. "I played the violin," Parvathy explaining.
 - 2. "I am playing the violin," Parvathy explained.
 - 3. "I playing the violin," Parvathy explained.
 - 4. "I playing the violin," Parvathy explain.

Question ID : 264330135985
Option 1 ID : 264330532785
Option 2 ID : 264330532786
Option 3 ID : 264330532784
Option 4 ID : 264330532783
Status : Answered
Chosen Option : 2

Q.18 Select the option that expresses the given sentence in active voice.
A window will have been opened by her.

- Ans
- 1. She will open a window.
 - 2. She will have been opened a window.
 - 3. She will have opened a window.
 - 4. She will be opened a window.

Question ID : 264330132778
Option 1 ID : 264330520207
Option 2 ID : 264330520209
Option 3 ID : 264330520210
Option 4 ID : 264330520208
Status : Answered
Chosen Option : 3

Q.19 The following sentence has been split into four segments. Identify the segment that contains a grammatical error.

Communicating what / you felt / wasn't always / easy in Rita.

- Ans
- 1. easy in Rita
 - 2. Communicating what
 - 3. you felt
 - 4. wasn't always

Question ID : 264330109064
Option 1 ID : 264330428536
Option 2 ID : 264330428533
Option 3 ID : 264330428534
Option 4 ID : 264330428535
Status : Answered
Chosen Option : 1

Q.20 One of the following parts of the given sentence may contain an error. Select the part that contains the error from the given options. If you don't find any error, mark 'No error' as your answer.

Jaya takes classes for two months to pass the National Eligibility test.

- Ans
- 1. No error
 - 2. For two months
 - 3. To pass the National Eligibility test
 - 4. Takes classes

Question ID : 264330120567
Option 1 ID : 264330472514
Option 2 ID : 264330472512
Option 3 ID : 264330472513
Option 4 ID : 264330472511
Status : Answered
Chosen Option : 4

Q.21 Select the most appropriate ANTONYM of the given word.
Collapse

- Ans 1. Flourish
 2. Flounder
 3. Slip
 4. Collaborate

Question ID : 264330137461
Option 1 ID : 264330538469
Option 2 ID : 264330538470
Option 3 ID : 264330538467
Option 4 ID : 264330538468
Status : Answered
Chosen Option : 1

Q.22 Select the option that expresses the following sentence in active voice.
A batch of cookies was baked for the party by her.

- Ans 1. A batch of cookies for the party she baked.
 2. She baked a batch of cookies for the party.
 3. She has been baking a batch of cookies for the party.
 4. For the party she has baked a batch of cookies.

Question ID : 264330168113
Option 1 ID : 264330659333
Option 2 ID : 264330659334
Option 3 ID : 264330659332
Option 4 ID : 264330659331
Status : Answered
Chosen Option : 2

Q.23 Select the most appropriate ANTONYM of the given word.

Opaque

- Ans 1. Transient
 2. Intelligible
 3. Conventional
 4. Volatile

Question ID : 264330141553
Option 1 ID : 264330554549
Option 2 ID : 264330554550
Option 3 ID : 264330554547
Option 4 ID : 264330554548
Status : Answered
Chosen Option : 2

Q.24 Sentences of a paragraph are given below in jumbled order. Arrange the sentences in the correct order to form a meaningful and coherent paragraph.

- A. This digital universe is not restricted to technology gadgets such as searching for information on the internet.
- B. A digital realm is created through metaverse technology.
- C. The human presence will be marked by the existence of avatars, which will be free to interact with one another in 3-D virtual spaces.
- D. You may not only glance at things in this, but you can also feel and mark your presence in augmented reality.

- Ans** ✓ 1. BADC
✗ 2. ABCD
✗ 3. BCDA
✗ 4. CDAB

Question ID : 264330117168
Option 1 ID : 264330460739
Option 2 ID : 264330460738
Option 3 ID : 264330460740
Option 4 ID : 264330460737
Status : Answered
Chosen Option : 4

Q.25 Select the option that expresses the following sentence in indirect speech.

Rahul says, "I go to the gym daily."

- Ans** ✓ 1. Rahul says that he goes to the gym daily.
✗ 2. Rahul told that he went to the gym daily.
✗ 3. Rahul explained that I go to the gym daily.
✗ 4. Rahul said that he goes to the gym every day.

Question ID : 264330163354
Option 1 ID : 264330640708
Option 2 ID : 264330640710
Option 3 ID : 264330640709
Option 4 ID : 264330640707
Status : Answered
Chosen Option : 1

Q.26 Select the most appropriate synonym of the given word.

Lavish

- Ans** ✗ 1. Meagre
✗ 2. Stylish
✓ 3. Luxurious
✗ 4. Unique

Question ID : 264330164165
Option 1 ID : 264330643911
Option 2 ID : 264330643913
Option 3 ID : 264330643912
Option 4 ID : 264330643914
Status : Answered
Chosen Option : 3

Q.27 Select the most appropriate option to fill in the blank.

The fire damaged the utensils so much that it was impossible to _____ them.

- Ans 1. retrieve
 2. retract
 3. retreat
 4. retrace

Question ID : 26433098893
Option 1 ID : 264330388226
Option 2 ID : 264330388227
Option 3 ID : 264330388225
Option 4 ID : 264330388228
Status : Answered
Chosen Option : 1

Q.28 The following sentence has been split into four segments. Identify the segment that contains an error.

Naira promise me / to show me how to / fish for salmon, / but he never had the time.

- Ans 1. but he never had the time.
 2. Naira promise me
 3. to show me how to
 4. fish for salmon,

Question ID : 264330164198
Option 1 ID : 264330644041
Option 2 ID : 264330644042
Option 3 ID : 264330644039
Option 4 ID : 264330644040
Status : Answered
Chosen Option : 2

Q.29 Select the option that expresses the given sentence in passive voice.
The government is implementing new policies to reduce pollution in the city.

- Ans 1. The implementation of new policies to reduce pollution in the city is by the government.
 2. The government implemented new policies to reduce pollution in the city.
 3. New policies are being implemented by the government to reduce pollution in the city.
 4. The government will implement new policies to reduce pollution in the city.

Question ID : 264330137482
Option 1 ID : 264330538547
Option 2 ID : 264330538549
Option 3 ID : 264330538550
Option 4 ID : 264330538548
Status : Answered
Chosen Option : 3

Q.30 Select the option that expresses the following sentence in reported (or indirect) speech.

The postmaster said to her, "You can purchase only two stamps at a time."

- Ans
- 1. The postmaster told her that she can purchase only two stamps at a time.
 - 2. The postmaster instructed her that she should purchase only two stamps at a time.
 - 3. The postmaster asked her that she could purchase only two stamps at a time.
 - 4. The postmaster told her that she could purchase only two stamps at a time.

Question ID : 264330164346

Option 1 ID : 264330644596

Option 2 ID : 264330644597

Option 3 ID : 264330644595

Option 4 ID : 264330644598

Status : Answered

Chosen Option : 4

Q.31 Select the most appropriate option that can substitute the underlined segment in the given sentence.

All the guests I have invited to the movie screening have shown unwilling due to their busy schedules.

- Ans
- 1. have shown unwillingness
 - 2. had shown unwilling
 - 3. are unwillingness
 - 4. are being unwilling

Question ID : 264330133432

Option 1 ID : 264330522760

Option 2 ID : 264330522759

Option 3 ID : 264330522762

Option 4 ID : 264330522761

Status : Answered

Chosen Option : 1

Q.32 Select the most appropriate ANTONYM of the given word.
Absolve

- Ans
- 1. Resolve
 - 2. Condemn
 - 3. Pardon
 - 4. Gratify

Question ID : 264330168138

Option 1 ID : 264330659430

Option 2 ID : 264330659427

Option 3 ID : 264330659429

Option 4 ID : 264330659428

Status : Answered

Chosen Option : 2

Q.33 Select the option that can substitute the underlined word segment with the most appropriate idiom.

26 January 1950 is a memorable day for the countrymen.

- Ans
- ✓ 1. red letter
 - ✗ 2. green thumb
 - ✗ 3. out of the blue
 - ✗ 4. black and white

Question ID : 264330165288

Option 1 ID : 264330648242

Option 2 ID : 264330648240

Option 3 ID : 264330648239

Option 4 ID : 264330648241

Status : Answered

Chosen Option : 1

Q.34 Choose the most suitable idiom for the given situation.

They don't talk to him anymore as he brought disgrace to the family by robbing the bank. They have ousted him and consider him as insult to the family name. He is

- Ans
- ✗ 1. a dark horse
 - ✗ 2. a fish out of water
 - ✗ 3. a crying wolf
 - ✓ 4. a black sheep

Question ID : 264330135904

Option 1 ID : 264330532471

Option 2 ID : 264330532473

Option 3 ID : 264330532474

Option 4 ID : 264330532472

Status : Answered

Chosen Option : 4

Q.35 Select the option that expresses the following sentence in direct speech.

Lata told me to give her a glass of water.

- Ans
- ✗ 1. Lata asked me, "Give me a glass of water."
 - ✓ 2. Lata said to me, "Give me a glass of water."
 - ✗ 3. Lata said, "Can you give her a glass of water."
 - ✗ 4. Lata said, "Give her a glass of water."

Question ID : 264330164348

Option 1 ID : 264330644605

Option 2 ID : 264330644604

Option 3 ID : 264330644606

Option 4 ID : 264330644603

Status : Answered

Chosen Option : 2

Q.36 Select the option that expresses the given sentence in active voice.

It is said that this is the oldest temple in the region.

- Ans
- 1. This is said to be the oldest temple in the region.
 - 2. This temple is said in the region to be.
 - 3. This oldest temple is said to be in the region.
 - 4. This is told to be the oldest temple.

Question ID : 264330164594

Option 1 ID : 264330645559

Option 2 ID : 264330645562

Option 3 ID : 264330645560

Option 4 ID : 264330645561

Status : Answered

Chosen Option : 4

Q.37 Select the most appropriate ANTONYM of the given word.
Compatible

- Ans
- 1. Helpful
 - 2. Inconsistent
 - 3. Energetic
 - 4. Immaculate

Question ID : 264330165245

Option 1 ID : 264330648080

Option 2 ID : 264330648081

Option 3 ID : 264330648079

Option 4 ID : 264330648082

Status : Answered

Chosen Option : 2

Q.38 Select the most appropriate option that can substitute the underlined segment in the given sentence.

She likes street food such that golgappe, tikka and chaat.

- Ans
- 1. street food which as
 - 2. street food such as
 - 3. street food that
 - 4. street food like as

Question ID : 264330117261

Option 1 ID : 264330461102

Option 2 ID : 264330461101

Option 3 ID : 264330461104

Option 4 ID : 264330461103

Status : Answered

Chosen Option : 2

Q.39 Select the option that expresses the given sentence in active voice.
The monkey was not chased up the tree by the lion.

- Ans
- 1. Up the tree the monkey was not chased by the lion.
 - 2. The lion was not chasing the monkey up the tree.
 - 3. The lion did not chase the monkey up the tree.
 - 4. The monkey was not chasing up the tree to the lion.

Question ID : 264330164246
Option 1 ID : 264330644218
Option 2 ID : 264330644215
Option 3 ID : 264330644217
Option 4 ID : 264330644216
Status : Answered
Chosen Option : 3

Q.40 The following sentence has been divided into parts. One of them may contain an error.
Select the part that contains the error from the given options. If you don't find any error, mark 'No error' as your answer.

Stella usually manages / the waste materials and / disposed them meticulously.

- Ans
- 1. disposed them meticulously
 - 2. Stella usually manages
 - 3. No error
 - 4. the waste materials and

Question ID : 26433094752
Option 1 ID : 264330371843
Option 2 ID : 264330371841
Option 3 ID : 264330371844
Option 4 ID : 264330371842
Status : Answered
Chosen Option : 1

Q.41 Select the option that expresses the given sentence in active voice.
A new laptop was bought by me yesterday.

- Ans
- 1. I bought a new laptop yesterday.
 - 2. I have been buying a laptop yesterday.
 - 3. I have buy a new laptop yesterday.
 - 4. I was bought a new laptop yesterday.

Question ID : 264330164355
Option 1 ID : 264330644634
Option 2 ID : 264330644632
Option 3 ID : 264330644633
Option 4 ID : 264330644631
Status : Answered
Chosen Option : 1

Q.42 Select the most appropriate option to fill in the blank.

The amount of sleep you require changes greatly throughout your life, _____ on your age, activity level, overall health, and lifestyle patterns.

- Ans 1. suspecting
 2. depending
 3. distrusting
 4. correlating

Question ID : 26433098922
Option 1 ID : 264330388344
Option 2 ID : 264330388341
Option 3 ID : 264330388343
Option 4 ID : 264330388342
Status : Answered
Chosen Option : 2

Q.43 Select the most appropriate idiom to substitute the underlined segment in the given sentence.

I was undecided for a long time to select the right course of study after my senior secondary exam.

- Ans 1. sitting on the fence
 2. beating around the bush
 3. on fool's errand
 4. knocking around

Question ID : 264330135906
Option 1 ID : 264330532479
Option 2 ID : 264330532480
Option 3 ID : 264330532481
Option 4 ID : 264330532482
Status : Answered
Chosen Option : 1

Q.44 Select the option that expresses the given sentence in indirect speech.

"We must be vigilant. Our teacher never accepts the assignment if any one of us is late in submission", Ramesh said to his friend.

- Ans 1. Ramesh told his friend that we must be vigilant as their teacher never accepted the assignment if any one of them was late in submission.
 2. Ramesh said to his friend that we must be vigilant as their teacher never accepted the assignment if any one of them was late in submission.
 3. Ramesh told his friend that they must be vigilant as their teacher never accepted the assignment if any one of them was late in submission.
 4. Ramesh said his friend that they must be vigilant as our teacher never accepted the assignment if any one of them was late in submission.

Question ID : 264330169773
Option 1 ID : 264330665784
Option 2 ID : 264330665783
Option 3 ID : 264330665786
Option 4 ID : 264330665785
Status : Answered
Chosen Option : 1

Q.45 Select the option that expresses the following sentence in active voice.
The pizza was ordered by Nikita at 5 p.m.

- Ans
- 1. Nikita ordered the pizza at 5 p.m.
 - 2. Nikita has being ordered the pizza at 5 p.m.
 - 3. Nikita had ordered the pizza at 5 p.m.
 - 4. Nikita has been ordered the pizza at 5 p.m.

Question ID : 264330164319
Option 1 ID : 264330644491
Option 2 ID : 264330644494
Option 3 ID : 264330644492
Option 4 ID : 264330644493
Status : Answered
Chosen Option : 1

Q.46 Select the most appropriate option to fill in the blank.
I could sense the _____ between husband and wife.

- Ans
- 1. tunelessness
 - 2. disharmony
 - 3. jangling
 - 4. raucous

Question ID : 264330168337
Option 1 ID : 264330660214
Option 2 ID : 264330660213
Option 3 ID : 264330660212
Option 4 ID : 264330660211
Status : Answered
Chosen Option : 2

Q.47 Select the most appropriate option to fill in the blank.

To avoid _____ on the roads, proper signs and signals should be put up.

- Ans
- 1. chuffing
 - 2. sleeping
 - 3. stuffing
 - 4. congestion

Question ID : 26433098900
Option 1 ID : 264330388253
Option 2 ID : 264330388254
Option 3 ID : 264330388256
Option 4 ID : 264330388255
Status : Answered
Chosen Option : 4

Q.48 Select the most appropriate ANTONYM of the given word.
Reluctantly

- Ans 1. Zealously
 2. Unwillingly
 3. Fairly
 4. Smartly

Question ID : 264330168281
Option 1 ID : 264330659992
Option 2 ID : 264330659991
Option 3 ID : 264330659993
Option 4 ID : 264330659994
Status : Answered
Chosen Option : 1

Q.49 Sentences of a paragraph are given below in jumbled order. Arrange the sentences in the correct order to form a meaningful and coherent paragraph.

- A. His original contributions to natural science include the accurate assessment of the elephant gestation period and the disclosure of the Sarus Crane pairing information.
B. His Tuzuk-i-Jahangiri contains a record of his observations (memoirs of Jahangir).
C. Jahangir, the emperor of the Mughal Empire, was a devoted naturalist.
D. Jahangir is known for his in-depth descriptions of several animals and birds, including the monkey and the hawk-cuckoo.

- Ans 1. CBDA
 2. ABCD
 3. DACB
 4. BDCA

Question ID : 26433098155
Option 1 ID : 264330385273
Option 2 ID : 264330385274
Option 3 ID : 264330385276
Option 4 ID : 264330385275
Status : Answered
Chosen Option : 1

Q.50 Sentences of a paragraph are given below in jumbled order. Arrange the sentences in the correct order to form a meaningful and coherent paragraph.

- A. United nations maintains peace and security in the world.
B. It also takes care of developing friendly relations between nations.
C. United Nations also strives to implement the principles of equality.
D. It also act as a centre through which countries coordinate their actions and activities for global peace.

- Ans 1. CDAB
 2. DCAB
 3. BCDA
 4. ABCD

Question ID : 26433098147
Option 1 ID : 264330385244
Option 2 ID : 264330385242
Option 3 ID : 264330385241
Option 4 ID : 264330385243
Status : Answered
Chosen Option : 4

Q.51 Select the most appropriate meaning of the given idiom.

To be in hot water

- Ans 1. To get into a difficult situation in which you are in danger of being drowned
2. To get into a difficult situation in which you are in danger of being choked to death
3. To get into a difficult situation in which you are in danger of being criticised or punished
4. To get into a difficult situation in which you are in danger of being burnt

Question ID : 264330163430
Option 1 ID : 264330640998
Option 2 ID : 264330640997
Option 3 ID : 264330640996
Option 4 ID : 264330640995
Status : Answered
Chosen Option : 3

Q.52 Select the option that expresses the given sentence in direct speech.

Minal said that they were boarding the train then.

- Ans 1. Minal said, "We have been boarding the train now."
2. Minal asked, "Are we boarding the train now?"
3. Minal told, "We would be boarding the train by then."
4. Minal said, "We are boarding the train now."

Question ID : 264330164597
Option 1 ID : 264330645573
Option 2 ID : 264330645574
Option 3 ID : 264330645571
Option 4 ID : 264330645572
Status : Answered
Chosen Option : 4

Q.53 Select the most appropriate ANTONYM of the given word.

Ruthless

- Ans 1. Hostile
2. Lenient
3. Resolute
4. Affluent

Question ID : 264330141552
Option 1 ID : 264330554543
Option 2 ID : 264330554544
Option 3 ID : 264330554545
Option 4 ID : 264330554546
Status : Answered
Chosen Option : 2

Q.54 The following sentence has been divided into parts. One of them may contain an error. Select the part that contains the error from the given options. If you don't find any error, mark 'No error' as your answer.

(1) Ravi walked / (2) up to a Principal's cabin / (3) but could not meet him. / (4) No error

- Ans
- 1. 1
 - 2. 4
 - 3. 2
 - 4. 3

Question ID : 264330164339
Option 1 ID : 264330644567
Option 2 ID : 264330644570
Option 3 ID : 264330644568
Option 4 ID : 264330644569
Status : Answered
Chosen Option : 2

Q.55 Select the most appropriate option that can substitute the underlined segment in the given sentence.

Don't see into my phone.

- Ans
- 1. look at
 - 2. watch into
 - 3. see through
 - 4. watch through

Question ID : 264330117267
Option 1 ID : 264330461128
Option 2 ID : 264330461125
Option 3 ID : 264330461126
Option 4 ID : 264330461127
Status : Answered
Chosen Option : 1

Q.56 Select the option that expresses the given sentence in passive voice.
They are constructing a new building in the city centre.

- Ans
- 1. They constructed a new building in the city centre.
 - 2. The construction of a new building in the city centre by them is ongoing
 - 3. A new building is being constructed by them in the city centre.
 - 4. They will construct a new building in the city centre.

Question ID : 264330137481
Option 1 ID : 264330538543
Option 2 ID : 264330538544
Option 3 ID : 264330538545
Option 4 ID : 264330538546
Status : Answered
Chosen Option : 3

Q.57 The following sentence has been divided into parts. One of them may contain an error. Select the part that contains the error from the given options. If you don't find any error, mark 'No error' as your answer.

(1) It is raining / (2) when they played / (3) the cricket match last night. / (4) No error

Ans 1. 1

2. 2

3. 4

4. 3

Question ID : 264330157039

Option 1 ID : 264330615531

Option 2 ID : 264330615532

Option 3 ID : 264330615534

Option 4 ID : 264330615533

Status : Answered

Chosen Option : 1

Q.58 Select the most appropriate option that can substitute the underlined segment in the given sentence.

I visited my friend for night.

Ans 1. with

2. in

3. from

4. at

Question ID : 264330117256

Option 1 ID : 264330461084

Option 2 ID : 264330461081

Option 3 ID : 264330461083

Option 4 ID : 264330461082

Status : Answered

Chosen Option : 2

Q.59 Select the most appropriate option that can substitute the underlined segment in the given sentence.

We are discussing for the same matter.

Ans 1. discussing about

2. discussing upon

3. discussing

4. discussing of

Question ID : 264330117254

Option 1 ID : 264330461073

Option 2 ID : 264330461076

Option 3 ID : 264330461075

Option 4 ID : 264330461074

Status : Answered

Chosen Option : 1

Q.60 Given below are four jumbled sentences select the option that gives their correct logical sequence

A. One common mistake that many people have made is this; they have thought that it would be a very good thing if everybody had exactly the same amount of money, no matter whether they worked hard or lived quite idly.

B. Now that is a very great mistake, because there simply is not enough money to make everybody rich.

C. And they have imagined that if all the money in the country were equally divided everybody would be rich

D. They forget that very few people would work at all if it were not for the money their work brings them, and that without work there would be no money

Ans ✓ 1. ADCB

✗ 2. ADBC

✗ 3. ABCD

✗ 4. ABDC

Question ID : 264330117436

Option 1 ID : 264330461785

Option 2 ID : 264330461786

Option 3 ID : 264330461787

Option 4 ID : 264330461788

Status : Answered

Chosen Option : 1

Q.61 The following sentence has been divided into parts. One of them may contain an error. Select the part that contains the error from the given options. If you don't find any error, mark 'No error' as your answer.
Thirty miles / are / a long way to walk.

Ans ✗ 1. No error

✗ 2. Thirty miles

✗ 3. a long way to walk

✓ 4. are

Question ID : 264330123027

Option 1 ID : 264330482174

Option 2 ID : 264330482171

Option 3 ID : 264330482173

Option 4 ID : 264330482172

Status : Answered

Chosen Option : 4

Q.62 Select the most appropriate synonym of the bracketed word in the following sentence to fill in the blank.

The Government is planning to irrigate the _____ desert land by using water from the nearby river. (parched)

Ans ✗ 1. lush

✓ 2. arid

✗ 3. only

✗ 4. rustic

Question ID : 264330163274

Option 1 ID : 264330640410

Option 2 ID : 264330640407

Option 3 ID : 264330640409

Option 4 ID : 264330640408

Status : Answered

Chosen Option : 2

Q.63 Select the most appropriate idiom that can substitute the underlined segment in the given sentence.

"I don't feel like hanging out today. I'm feeling a bit unwell."

- Ans
- 1. under the coat
 - 2. under the weather
 - 3. near the horizon
 - 4. over the moon

Question ID : 264330164572
Option 1 ID : 264330645475
Option 2 ID : 264330645477
Option 3 ID : 264330645478
Option 4 ID : 264330645476
Status : Answered
Chosen Option : 2

Q.64 Select the most appropriate option to fill in the blank.

Hitler's concentration camps _____ the bodies of the dead captives subsequently.

- Ans
- 1. mutilated
 - 2. conspired
 - 3. exaggerated
 - 4. resounded

Question ID : 264330164613
Option 1 ID : 264330645637
Option 2 ID : 264330645638
Option 3 ID : 264330645635
Option 4 ID : 264330645636
Status : Answered
Chosen Option : 1

Q.65 Select the option that expresses the given sentence in reported speech.
Shyla said to me, "What a skilful tailor she is!"

- Ans
- 1. Shyla exclaimed that she is a very skilful tailor.
 - 2. Shyla said that she was a very skilful tailor.
 - 3. Shyla exclaimed that she was a very skilful tailor.
 - 4. Shyla exclaimed to me if she was a very skilful tailor.

Question ID : 264330139316
Option 1 ID : 264330545756
Option 2 ID : 264330545757
Option 3 ID : 264330545755
Option 4 ID : 264330545758
Status : Answered
Chosen Option : 3

Comprehension:

In the following passage, some words have been deleted. Read the passage carefully and select the most appropriate option to fill in each blank.

Climate change is a pressing global issue that demands immediate (1) _____. The Earth's climate is undergoing (2) _____ changes primarily due to human activities, such as burning fossil fuels and deforestation. The consequences of climate change are (3) _____ and include rising global temperatures, extreme weather events, and biodiversity loss. To mitigate these effects, it is crucial to reduce greenhouse gas emissions, promote renewable energy sources, and adopt sustainable (4) _____. Additionally, raising awareness and educating the public about the importance of conservation and environmentally friendly practices are essential. Cooperation and international (5) _____ are needed to address climate change collectively.

SubQuestion No : 66**Q.66** Select the most appropriate option to fill in blank number 1.

- Ans 1. action
 2. apathy
 3. difference
 4. delay

Question ID : 264330164645

Option 1 ID : 264330645755

Option 2 ID : 264330645758

Option 3 ID : 264330645757

Option 4 ID : 264330645756

Status : Answered

Chosen Option : 1

Comprehension:

In the following passage, some words have been deleted. Read the passage carefully and select the most appropriate option to fill in each blank.

Climate change is a pressing global issue that demands immediate (1) _____. The Earth's climate is undergoing (2) _____ changes primarily due to human activities, such as burning fossil fuels and deforestation. The consequences of climate change are (3) _____ and include rising global temperatures, extreme weather events, and biodiversity loss. To mitigate these effects, it is crucial to reduce greenhouse gas emissions, promote renewable energy sources, and adopt sustainable (4) _____. Additionally, raising awareness and educating the public about the importance of conservation and environmentally friendly practices are essential. Cooperation and international (5) _____ are needed to address climate change collectively.

SubQuestion No : 67**Q.67** Select the most appropriate option to fill in blank number 2.

- Ans 1. profound
 2. simple
 3. hard
 4. honest

Question ID : 264330164646

Option 1 ID : 264330645760

Option 2 ID : 264330645759

Option 3 ID : 264330645762

Option 4 ID : 264330645761

Status : Answered

Chosen Option : 1

Comprehension:

In the following passage, some words have been deleted. Read the passage carefully and select the most appropriate option to fill in each blank.

Climate change is a pressing global issue that demands immediate (1) _____. The Earth's climate is undergoing (2) _____ changes primarily due to human activities, such as burning fossil fuels and deforestation. The consequences of climate change are (3) _____ and include rising global temperatures, extreme weather events, and biodiversity loss. To mitigate these effects, it is crucial to reduce greenhouse gas emissions, promote renewable energy sources, and adopt sustainable (4) _____. Additionally, raising awareness and educating the public about the importance of conservation and environmentally friendly practices are essential. Cooperation and international (5) _____ are needed to address climate change collectively.

SubQuestion No : 68

Q.68 Select the most appropriate option to fill in blank number 3.

- Ans
- 1. short-sighted
 - 2. far-reaching
 - 3. clean
 - 4. inadequate

Question ID : 264330164647

Option 1 ID : 264330645764

Option 2 ID : 264330645763

Option 3 ID : 264330645765

Option 4 ID : 264330645766

Status : Answered

Chosen Option : 1

Comprehension:

In the following passage, some words have been deleted. Read the passage carefully and select the most appropriate option to fill in each blank.

Climate change is a pressing global issue that demands immediate (1) _____. The Earth's climate is undergoing (2) _____ changes primarily due to human activities, such as burning fossil fuels and deforestation. The consequences of climate change are (3) _____ and include rising global temperatures, extreme weather events, and biodiversity loss. To mitigate these effects, it is crucial to reduce greenhouse gas emissions, promote renewable energy sources, and adopt sustainable (4) _____. Additionally, raising awareness and educating the public about the importance of conservation and environmentally friendly practices are essential. Cooperation and international (5) _____ are needed to address climate change collectively.

SubQuestion No : 69

Q.69 Select the most appropriate option to fill in blank number 4.

- Ans
- 1. solutions
 - 2. results
 - 3. effects
 - 4. consequences

Question ID : 264330164648

Option 1 ID : 264330645768

Option 2 ID : 264330645767

Option 3 ID : 264330645770

Option 4 ID : 264330645769

Status : Answered

Chosen Option : 1

Comprehension:

In the following passage, some words have been deleted. Read the passage carefully and select the most appropriate option to fill in each blank.

Climate change is a pressing global issue that demands immediate (1) _____. The Earth's climate is undergoing (2) _____ changes primarily due to human activities, such as burning fossil fuels and deforestation. The consequences of climate change are (3) _____ and include rising global temperatures, extreme weather events, and biodiversity loss. To mitigate these effects, it is crucial to reduce greenhouse gas emissions, promote renewable energy sources, and adopt sustainable (4) _____. Additionally, raising awareness and educating the public about the importance of conservation and environmentally friendly practices are essential. Cooperation and international (5) _____ are needed to address climate change collectively.

SubQuestion No : 70

Q.70 Select the most appropriate option to fill in blank number 5.

- Ans
- 1. direction
 - 2. cases
 - 3. efforts
 - 4. instances

Question ID : 264330164649

Option 1 ID : 264330645771

Option 2 ID : 264330645773

Option 3 ID : 264330645774

Option 4 ID : 264330645772

Status : Answered

Chosen Option : 3

Comprehension:

In the following passage, some words have been deleted. Read the passage carefully and select the most appropriate option to fill in each blank.

KIPS, with its vast (1) _____ in School Computer Education, (2) _____ the computer Series- Cyber Beans. This is the (3) _____ comprehensive computer series, (4) _____ is free from rote learning. While designing this series, a lot of effort has been put in to give each (5) _____ a practical shape.

SubQuestion No : 71

Q.71 Select the most appropriate option to fill in blank 1.

- Ans
- 1. membership
 - 2. belief
 - 3. share
 - 4. experience

Question ID : 264330167885

Option 1 ID : 264330658471

Option 2 ID : 264330658474

Option 3 ID : 264330658472

Option 4 ID : 264330658473

Status : Answered

Chosen Option : 4

Comprehension:

In the following passage, some words have been deleted. Read the passage carefully and select the most appropriate option to fill in each blank.

KIPS, with its vast (1)_____ in School Computer Education, (2)_____ the computer Series- Cyber Beans. This is the (3)_____ comprehensive computer series, (4)_____ is free from rote learning. While designing this series, a lot of effort has been put in to give each (5)_____ a practical shape.

SubQuestion No : 72**Q.72 Select the most appropriate option to fill in blank 2.**

- Ans 1. will design
 2. has designed
 3. is designing
 4. designed

Question ID : 264330167886

Option 1 ID : 264330658478

Option 2 ID : 264330658476

Option 3 ID : 264330658475

Option 4 ID : 264330658477

Status : Answered

Chosen Option : 2

Comprehension:

In the following passage, some words have been deleted. Read the passage carefully and select the most appropriate option to fill in each blank.

KIPS, with its vast (1)_____ in School Computer Education, (2)_____ the computer Series- Cyber Beans. This is the (3)_____ comprehensive computer series, (4)_____ is free from rote learning. While designing this series, a lot of effort has been put in to give each (5)_____ a practical shape.

SubQuestion No : 73**Q.73 Select the most appropriate option to fill in blank 3.**

- Ans 1. more
 2. least
 3. most
 4. great

Question ID : 264330167887

Option 1 ID : 264330658479

Option 2 ID : 264330658482

Option 3 ID : 264330658480

Option 4 ID : 264330658481

Status : Answered

Chosen Option : 3

Comprehension:

In the following passage, some words have been deleted. Read the passage carefully and select the most appropriate option to fill in each blank.

KIPS, with its vast (1)_____ in School Computer Education, (2)_____ the computer Series- Cyber Beans. This is the (3)_____ comprehensive computer series, (4)_____ is free from rote learning. While designing this series, a lot of effort has been put in to give each (5)_____ a practical shape.

SubQuestion No : 74

Q.74 Select the most appropriate option to fill in blank 4.

- Ans 1. who
 2. which
 3. that
 4. whose

Question ID : 264330167888

Option 1 ID : 264330658483

Option 2 ID : 264330658486

Option 3 ID : 264330658485

Option 4 ID : 264330658484

Status : Answered

Chosen Option : 2

Comprehension:

In the following passage, some words have been deleted. Read the passage carefully and select the most appropriate option to fill in each blank.

KIPS, with its vast (1)_____ in School Computer Education, (2)_____ the computer Series- Cyber Beans. This is the (3)_____ comprehensive computer series, (4)_____ is free from rote learning. While designing this series, a lot of effort has been put in to give each (5)_____ a practical shape.

SubQuestion No : 75

Q.75 Select the most appropriate option to fill in blank 5.

- Ans 1. aspect
 2. concept
 3. process
 4. views

Question ID : 264330167889

Option 1 ID : 264330658490

Option 2 ID : 264330658487

Option 3 ID : 264330658489

Option 4 ID : 264330658488

Status : Answered

Chosen Option : 2

Comprehension:

In the following passage, some words have been deleted. Read the passage carefully and select the most appropriate option to fill in each blank.

Exploitation in the marketplace happens in various (1)_____. For example, sometimes traders indulge in (2)_____ trade practices such as when shopkeepers weigh less than what they should or when traders add charges that were not mentioned before, or when (3)_____ goods are sold. Markets do not work in a fair manner when producers are few and powerful whereas consumers purchase in small amounts and are (4)_____. This happens especially when large companies are producing these goods. These companies with huge wealth, power and reach can (5)_____ the market in various ways.

SubQuestion No : 76

Q.76 Select the most appropriate option to fill in blank number 1.

- Ans 1. means
 2. status
 3. ways
 4. paths

Question ID : 264330168129

Option 1 ID : 264330659391

Option 2 ID : 264330659394

Option 3 ID : 264330659392

Option 4 ID : 264330659393

Status : Answered

Chosen Option : 1

Comprehension:

In the following passage, some words have been deleted. Read the passage carefully and select the most appropriate option to fill in each blank.

Exploitation in the marketplace happens in various (1)_____. For example, sometimes traders indulge in (2)_____ trade practices such as when shopkeepers weigh less than what they should or when traders add charges that were not mentioned before, or when (3)_____ goods are sold. Markets do not work in a fair manner when producers are few and powerful whereas consumers purchase in small amounts and are (4)_____. This happens especially when large companies are producing these goods. These companies with huge wealth, power and reach can (5)_____ the market in various ways.

SubQuestion No : 77

Q.77 Select the most appropriate option to fill in blank number 2.

- Ans 1. decent
 2. partial
 3. ethical
 4. unfair

Question ID : 264330168130

Option 1 ID : 264330659396

Option 2 ID : 264330659395

Option 3 ID : 264330659398

Option 4 ID : 264330659397

Status : Answered

Chosen Option : 4

Comprehension:

In the following passage, some words have been deleted. Read the passage carefully and select the most appropriate option to fill in each blank.

Exploitation in the marketplace happens in various (1)_____. For example, sometimes traders indulge in (2)_____ trade practices such as when shopkeepers weigh less than what they should or when traders add charges that were not mentioned before, or when (3)_____ goods are sold. Markets do not work in a fair manner when producers are few and powerful whereas consumers purchase in small amounts and are (4)_____. This happens especially when large companies are producing these goods. These companies with huge wealth, power and reach can (5)_____ the market in various ways.

SubQuestion No : 78

Q.78 Select the most appropriate option to fill in blank number 3.

- Ans 1. liquid
 2. adulterated
 3. diseased
 4. purified

Question ID : 264330168131

Option 1 ID : 264330659399

Option 2 ID : 264330659402

Option 3 ID : 264330659400

Option 4 ID : 264330659401

Status : Answered

Chosen Option : 2

Comprehension:

In the following passage, some words have been deleted. Read the passage carefully and select the most appropriate option to fill in each blank.

Exploitation in the marketplace happens in various (1)_____. For example, sometimes traders indulge in (2)_____ trade practices such as when shopkeepers weigh less than what they should or when traders add charges that were not mentioned before, or when (3)_____ goods are sold. Markets do not work in a fair manner when producers are few and powerful whereas consumers purchase in small amounts and are (4)_____. This happens especially when large companies are producing these goods. These companies with huge wealth, power and reach can (5)_____ the market in various ways.

SubQuestion No : 79

Q.79 Select the most appropriate option to fill in blank number 4.

- Ans 1. concentrated
 2. scattered
 3. organised
 4. disorderly

Question ID : 264330168132

Option 1 ID : 264330659406

Option 2 ID : 264330659405

Option 3 ID : 264330659403

Option 4 ID : 264330659404

Status : Answered

Chosen Option : 2

Comprehension:

In the following passage, some words have been deleted. Read the passage carefully and select the most appropriate option to fill in each blank.

Exploitation in the marketplace happens in various (1)_____. For example, sometimes traders indulge in (2)_____ trade practices such as when shopkeepers weigh less than what they should or when traders add charges that were not mentioned before, or when (3)_____ goods are sold. Markets do not work in a fair manner when producers are few and powerful whereas consumers purchase in small amounts and are (4)_____. This happens especially when large companies are producing these goods. These companies with huge wealth, power and reach can (5)_____ the market in various ways.

SubQuestion No : 80**Q.80** Select the most appropriate option to fill in blank number 5.

- Ans 1. surrender
 2. manipulate
 3. exercise
 4. employ

Question ID : 264330168133

Option 1 ID : 264330659407

Option 2 ID : 264330659410

Option 3 ID : 264330659408

Option 4 ID : 264330659409

Status : Answered

Chosen Option : 2

Comprehension:

In the following passage, some words have been deleted. Read the passage carefully and select the most appropriate option to fill in each blank.

A stone that is constantly rolling cannot gather moss, while a stone that remains lying in one (1)_____ will gather it after a time. In the same way, a man who is a rolling stone, who is constantly (2)_____ his occupations and pursuits, and does not settle (3)_____ long for any particular work, achieves little or no (4)_____ in life. One who is constantly chopping and changing will never become wealthy and get success in life. He will merely be dissipating his energies, and will get nowhere. As the proverb says, 'He who hunts two hares, loses (5)_____'.

SubQuestion No : 81**Q.81** Select the most appropriate option to fill in blank 1.

- Ans 1. place
 2. society
 3. locality
 4. size

Question ID : 264330168353

Option 1 ID : 264330660273

Option 2 ID : 264330660271

Option 3 ID : 264330660274

Option 4 ID : 264330660272

Status : Answered

Chosen Option : 1

Comprehension:

In the following passage, some words have been deleted. Read the passage carefully and select the most appropriate option to fill in each blank.

A stone that is constantly rolling cannot gather moss , while a stone that remains lying in one (1)_____ will gather it after a time. In the same way, a man who is a rolling stone, who is constantly (2)_____ his occupations and pursuits, and does not settle (3)_____ long for any particular work, achieves little or no (4)_____ in life. One who is constantly chopping and changing will never become wealthy and get success in life. He will merely be dissipating his energies, and will get nowhere. As the proverb says , 'He who hunts two hares, loses (5)_____':.

SubQuestion No : 82**Q.82 Select the most appropriate option to fill in blank 2.****Ans** ✓ 1. changing

✗ 2. active

✗ 3. agile

✗ 4. moving

Question ID : 264330168354

Option 1 ID : 264330660278

Option 2 ID : 264330660276

Option 3 ID : 264330660277

Option 4 ID : 264330660275

Status : Answered

Chosen Option : 1

Comprehension:

In the following passage, some words have been deleted. Read the passage carefully and select the most appropriate option to fill in each blank.

A stone that is constantly rolling cannot gather moss , while a stone that remains lying in one (1)_____ will gather it after a time. In the same way, a man who is a rolling stone, who is constantly (2)_____ his occupations and pursuits, and does not settle (3)_____ long for any particular work, achieves little or no (4)_____ in life. One who is constantly chopping and changing will never become wealthy and get success in life. He will merely be dissipating his energies, and will get nowhere. As the proverb says , 'He who hunts two hares, loses (5)_____':.

SubQuestion No : 83**Q.83 Select the most appropriate option to fill in blank 3.****Ans** ✓ 1. down

✗ 2. below

✗ 3. upon

✗ 4. after

Question ID : 264330168355

Option 1 ID : 264330660280

Option 2 ID : 264330660281

Option 3 ID : 264330660282

Option 4 ID : 264330660279

Status : Answered

Chosen Option : 1

Comprehension:

In the following passage, some words have been deleted. Read the passage carefully and select the most appropriate option to fill in each blank.

A stone that is constantly rolling cannot gather moss, while a stone that remains lying in one (1)_____ will gather it after a time. In the same way, a man who is a rolling stone, who is constantly (2)_____ his occupations and pursuits, and does not settle (3)_____ long for any particular work, achieves little or no (4)_____ in life. One who is constantly chopping and changing will never become wealthy and get success in life. He will merely be dissipating his energies, and will get nowhere. As the proverb says, 'He who hunts two hares, loses (5)_____':.

SubQuestion No : 84**Q.84** Select the most appropriate option to fill in blank 4.

- Ans
- 1. seniority
 - 2. priority
 - 3. majority
 - 4. success

Question ID : 264330168356

Option 1 ID : 264330660286

Option 2 ID : 264330660284

Option 3 ID : 264330660283

Option 4 ID : 264330660285

Status : Answered

Chosen Option : 4

Comprehension:

In the following passage, some words have been deleted. Read the passage carefully and select the most appropriate option to fill in each blank.

A stone that is constantly rolling cannot gather moss, while a stone that remains lying in one (1)_____ will gather it after a time. In the same way, a man who is a rolling stone, who is constantly (2)_____ his occupations and pursuits, and does not settle (3)_____ long for any particular work, achieves little or no (4)_____ in life. One who is constantly chopping and changing will never become wealthy and get success in life. He will merely be dissipating his energies, and will get nowhere. As the proverb says, 'He who hunts two hares, loses (5)_____':.

SubQuestion No : 85**Q.85** Select the most appropriate option to fill in blank 5.

- Ans
- 1. equal
 - 2. both
 - 3. nothing
 - 4. everything

Question ID : 264330168357

Option 1 ID : 264330660290

Option 2 ID : 264330660289

Option 3 ID : 264330660287

Option 4 ID : 264330660288

Status : Answered

Chosen Option : 2

Comprehension:

Read the given passage and answer the questions that follow.

World heritage refers to cultural or natural landmarks that have been recognised by the United Nations Educational, Scientific and Cultural Organization (UNESCO) for their outstanding value to humanity. These landmarks are considered to be of great importance to human history and culture and are therefore protected by international treaties to ensure their preservation for future generations.

One of the most important aspects of World Heritage Sites is their cultural significance. These sites are often associated with important events or people that have had a major impact on human history. For example, the Great Wall of China is recognised as a World Heritage Site because of its historical and cultural importance to China and the world. The wall was constructed over a period of centuries to protect China from invasion and has become a symbol of China's strength and determination.

Another important aspect of World Heritage Sites is their natural beauty. These sites are often recognised for their unique geological formations, breath-taking landscapes and diverse ecosystems. The Great Barrier Reef in Australia, for example, is a World Heritage Site because of its unparalleled biodiversity and natural beauty. The reef is home to thousands of species of marine life and provides an important habitat for many endangered species.

Preserving World Heritage Sites is crucial for maintaining their cultural and natural significance. Many sites are under threat from a variety of factors, including climate change, natural disasters and human activities such as tourism and development. For this reason, UNESCO works with governments and local communities around the world to develop strategies for protecting and preserving these important landmarks.

Despite these efforts, many World Heritage Sites continue to face threats. For example, the ancient city of Palmyra in Syria, which was recognised as a World Heritage Site in 1980, was extensively damaged by ISIS militants in 2015. The destruction of this important cultural site was a devastating loss for the people of Syria and the world.

In conclusion, World Heritage Sites are of great importance to humanity, and their preservation is crucial for maintaining our cultural and natural heritage. The recognition of these sites by UNESCO is an important step towards their protection and preservation for future generations.

SubQuestion No : 86

Q.86 What are some of the factors that threaten World Heritage Sites?

- Ans
- 1. Political unrest, wars and terrorism
 - 2. Lack of funding and government support through many institutions
 - 3. A decline in public interest and appreciation for cultural demands
 - 4. Climate change, natural disasters and human activities such as tourism and development

Question ID : 264330167921

Option 1 ID : 264330658595

Option 2 ID : 264330658596

Option 3 ID : 264330658598

Option 4 ID : 264330658597

Status : Answered

Chosen Option : 4

Comprehension:

Read the given passage and answer the questions that follow.

World heritage refers to cultural or natural landmarks that have been recognised by the United Nations Educational, Scientific and Cultural Organization (UNESCO) for their outstanding value to humanity. These landmarks are considered to be of great importance to human history and culture and are therefore protected by international treaties to ensure their preservation for future generations.

One of the most important aspects of World Heritage Sites is their cultural significance. These sites are often associated with important events or people that have had a major impact on human history. For example, the Great Wall of China is recognised as a World Heritage Site because of its historical and cultural importance to China and the world. The wall was constructed over a period of centuries to protect China from invasion and has become a symbol of China's strength and determination.

Another important aspect of World Heritage Sites is their natural beauty. These sites are often recognised for their unique geological formations, breath-taking landscapes and diverse ecosystems. The Great Barrier Reef in Australia, for example, is a World Heritage Site because of its unparalleled biodiversity and natural beauty. The reef is home to thousands of species of marine life and provides an important habitat for many endangered species.

Preserving World Heritage Sites is crucial for maintaining their cultural and natural significance. Many sites are under threat from a variety of factors, including climate change, natural disasters and human activities such as tourism and development. For this reason, UNESCO works with governments and local communities around the world to develop strategies for protecting and preserving these important landmarks.

Despite these efforts, many World Heritage Sites continue to face threats. For example, the ancient city of Palmyra in Syria, which was recognised as a World Heritage Site in 1980, was extensively damaged by ISIS militants in 2015. The destruction of this important cultural site was a devastating loss for the people of Syria and the world.

In conclusion, World Heritage Sites are of great importance to humanity, and their preservation is crucial for maintaining our cultural and natural heritage. The recognition of these sites by UNESCO is an important step towards their protection and preservation for future generations.

SubQuestion No : 87

Q.87 Which of the following would be the most suitable title for this passage?

- Ans 1. The importance of World Heritage Sites to human history and culture
2. The threats facing World Heritage Sites due to humans
3. World Heritage Sites—a natural beauty to explore
4. The role of UNESCO in protecting World Heritage Sites

Question ID : 264330167920

Option 1 ID : 264330658591

Option 2 ID : 264330658593

Option 3 ID : 264330658592

Option 4 ID : 264330658594

Status : Answered

Chosen Option : 4

Comprehension:

Read the given passage and answer the questions that follow.

World heritage refers to cultural or natural landmarks that have been recognised by the United Nations Educational, Scientific and Cultural Organization (UNESCO) for their outstanding value to humanity. These landmarks are considered to be of great importance to human history and culture and are therefore protected by international treaties to ensure their preservation for future generations.

One of the most important aspects of World Heritage Sites is their cultural significance. These sites are often associated with important events or people that have had a major impact on human history. For example, the Great Wall of China is recognised as a World Heritage Site because of its historical and cultural importance to China and the world. The wall was constructed over a period of centuries to protect China from invasion and has become a symbol of China's strength and determination.

Another important aspect of World Heritage Sites is their natural beauty. These sites are often recognised for their unique geological formations, breath-taking landscapes and diverse ecosystems. The Great Barrier Reef in Australia, for example, is a World Heritage Site because of its unparalleled biodiversity and natural beauty. The reef is home to thousands of species of marine life and provides an important habitat for many endangered species. Preserving World Heritage Sites is crucial for maintaining their cultural and natural significance. Many sites are under threat from a variety of factors, including climate change, natural disasters and human activities such as tourism and development. For this reason, UNESCO works with governments and local communities around the world to develop strategies for protecting and preserving these important landmarks.

Despite these efforts, many World Heritage Sites continue to face threats. For example, the ancient city of Palmyra in Syria, which was recognised as a World Heritage Site in 1980, was extensively damaged by ISIS militants in 2015. The destruction of this important cultural site was a devastating loss for the people of Syria and the world.

In conclusion, World Heritage Sites are of great importance to humanity, and their preservation is crucial for maintaining our cultural and natural heritage. The recognition of these sites by UNESCO is an important step towards their protection and preservation for future generations.

SubQuestion No : 88

Q.88 How does UNESCO work to protect World Heritage Sites?

- Ans**
- 1. By enforcing strict laws and regulations to prevent any damage or destruction
 - 2. By working with governments and local communities to develop strategies for their preservation
 - 3. By conducting regular inspections and assessments to identify potential threats and risks
 - 4. By limiting access to the sites to reduce the impact of tourism and development

Question ID : 264330167922

Option 1 ID : 264330658602

Option 2 ID : 264330658599

Option 3 ID : 264330658600

Option 4 ID : 264330658601

Status : Answered

Chosen Option : 2

Comprehension:

Read the given passage and answer the questions that follow.

World heritage refers to cultural or natural landmarks that have been recognised by the United Nations Educational, Scientific and Cultural Organization (UNESCO) for their outstanding value to humanity. These landmarks are considered to be of great importance to human history and culture and are therefore protected by international treaties to ensure their preservation for future generations.

One of the most important aspects of World Heritage Sites is their cultural significance. These sites are often associated with important events or people that have had a major impact on human history. For example, the Great Wall of China is recognised as a World Heritage Site because of its historical and cultural importance to China and the world. The wall was constructed over a period of centuries to protect China from invasion and has become a symbol of China's strength and determination.

Another important aspect of World Heritage Sites is their natural beauty. These sites are often recognised for their unique geological formations, breath-taking landscapes and diverse ecosystems. The Great Barrier Reef in Australia, for example, is a World Heritage Site because of its unparalleled biodiversity and natural beauty. The reef is home to thousands of species of marine life and provides an important habitat for many endangered species.

Preserving World Heritage Sites is crucial for maintaining their cultural and natural significance. Many sites are under threat from a variety of factors, including climate change, natural disasters and human activities such as tourism and development. For this reason, UNESCO works with governments and local communities around the world to develop strategies for protecting and preserving these important landmarks.

Despite these efforts, many World Heritage Sites continue to face threats. For example, the ancient city of Palmyra in Syria, which was recognised as a World Heritage Site in 1980, was extensively damaged by ISIS militants in 2015. The destruction of this important cultural site was a devastating loss for the people of Syria and the world.

In conclusion, World Heritage Sites are of great importance to humanity, and their preservation is crucial for maintaining our cultural and natural heritage. The recognition of these sites by UNESCO is an important step towards their protection and preservation for future generations.

SubQuestion No : 89

Q.89 Find the ANTONYM of the word 'unparalleled'

- Ans
- 1. Strategies
 - 2. Devastation
 - 3. Barrier
 - 4. Frequent

Question ID : 264330167924

Option 1 ID : 264330658608

Option 2 ID : 264330658607

Option 3 ID : 264330658610

Option 4 ID : 264330658609

Status : Answered

Chosen Option : 2

Comprehension:

Read the given passage and answer the questions that follow.

World heritage refers to cultural or natural landmarks that have been recognised by the United Nations Educational, Scientific and Cultural Organization (UNESCO) for their outstanding value to humanity. These landmarks are considered to be of great importance to human history and culture and are therefore protected by international treaties to ensure their preservation for future generations.

One of the most important aspects of World Heritage Sites is their cultural significance. These sites are often associated with important events or people that have had a major impact on human history. For example, the Great Wall of China is recognised as a World Heritage Site because of its historical and cultural importance to China and the world. The wall was constructed over a period of centuries to protect China from invasion and has become a symbol of China's strength and determination.

Another important aspect of World Heritage Sites is their natural beauty. These sites are often recognised for their unique geological formations, breath-taking landscapes and diverse ecosystems. The Great Barrier Reef in Australia, for example, is a World Heritage Site because of its unparalleled biodiversity and natural beauty. The reef is home to thousands of species of marine life and provides an important habitat for many endangered species.

Preserving World Heritage Sites is crucial for maintaining their cultural and natural significance. Many sites are under threat from a variety of factors, including climate change, natural disasters and human activities such as tourism and development. For this reason, UNESCO works with governments and local communities around the world to develop strategies for protecting and preserving these important landmarks.

Despite these efforts, many World Heritage Sites continue to face threats. For example, the ancient city of Palmyra in Syria, which was recognised as a World Heritage Site in 1980, was extensively damaged by ISIS militants in 2015. The destruction of this important cultural site was a devastating loss for the people of Syria and the world.

In conclusion, World Heritage Sites are of great importance to humanity, and their preservation is crucial for maintaining our cultural and natural heritage. The recognition of these sites by UNESCO is an important step towards their protection and preservation for future generations.

SubQuestion No : 90

Q.90 Identify the structure of the passage.

- Ans
- 1. Chronological
 - 2. Compare and contrast
 - 3. Cause and effect
 - 4. Problem and solution

Question ID : 264330167923

Option 1 ID : 264330658604

Option 2 ID : 264330658605

Option 3 ID : 264330658603

Option 4 ID : 264330658606

Status : Answered

Chosen Option : 4

Comprehension:

Read the given passage and answer the questions that follow.

Wuthering Heights, penned by Emily Bronte, is a captivating novel set on the desolate moors of Yorkshire. The story revolves around the intense relationships and obsessions of its characters. The narrative begins with Mr. Lockwood, who rents Thrushcross Grange from the enigmatic Heathcliff. Intrigued by the neighbouring farmhouse, Wuthering Heights, Lockwood delves into the complex history of the Earnshaw and Linton families. The heart of the story focuses on the passionate love affair between Heathcliff and Catherine Earnshaw, which leads to betrayal and revenge. Heathcliff's thirst for vengeance drives the plot, inflicting suffering upon those who wronged him, particularly Edgar Linton and Isabella. The novel explores themes of love, revenge, social class, and the destructive power of unchecked passion. Wuthering Heights presents complex characters, most notably Heathcliff, who challenges conventional notions of heroism and romance. Against the backdrop of the wild moors, Bronte weaves a dark and haunting tale that continues to captivate readers.

SubQuestion No : 91

Q.91 How does Heathcliff challenge conventional notions of heroism?

- Ans 1. By showing extreme emotions of obsession, exacting revenge and inflicting pain on others
2. By living in the Wuthering Heights manor
3. By being extremely passionate
4. By falling in love with Catherine

Question ID : 264330165272

Option 1 ID : 264330648175

Option 2 ID : 264330648177

Option 3 ID : 264330648178

Option 4 ID : 264330648176

Status : Answered

Chosen Option : 1

Comprehension:

Read the given passage and answer the questions that follow.

Wuthering Heights, penned by Emily Bronte, is a captivating novel set on the desolate moors of Yorkshire. The story revolves around the intense relationships and obsessions of its characters. The narrative begins with Mr. Lockwood, who rents Thrushcross Grange from the enigmatic Heathcliff. Intrigued by the neighbouring farmhouse, Wuthering Heights, Lockwood delves into the complex history of the Earnshaw and Linton families. The heart of the story focuses on the passionate love affair between Heathcliff and Catherine Earnshaw, which leads to betrayal and revenge. Heathcliff's thirst for vengeance drives the plot, inflicting suffering upon those who wronged him, particularly Edgar Linton and Isabella. The novel explores themes of love, revenge, social class, and the destructive power of unchecked passion. Wuthering Heights presents complex characters, most notably Heathcliff, who challenges conventional notions of heroism and romance. Against the backdrop of the wild moors, Bronte weaves a dark and haunting tale that continues to captivate readers.

SubQuestion No : 92

Q.92 Identify the central theme of the passage.

- Ans 1. The affair between Heathcliff and Catherine
2. Heathcliff's thirst for revenge
3. Summary of Wuthering Heights
4. Life of Emily Bronte

Question ID : 264330165270

Option 1 ID : 264330648169

Option 2 ID : 264330648170

Option 3 ID : 264330648167

Option 4 ID : 264330648168

Status : Answered

Chosen Option : 1

Comprehension:

Read the given passage and answer the questions that follow.

Wuthering Heights, penned by Emily Bronte, is a captivating novel set on the desolate moors of Yorkshire. The story revolves around the intense relationships and obsessions of its characters. The narrative begins with Mr. Lockwood, who rents Thrushcross Grange from the enigmatic Heathcliff. Intrigued by the neighbouring farmhouse, Wuthering Heights, Lockwood delves into the complex history of the Earnshaw and Linton families. The heart of the story focuses on the passionate love affair between Heathcliff and Catherine Earnshaw, which leads to betrayal and revenge. Heathcliff's thirst for vengeance drives the plot, inflicting suffering upon those who wronged him, particularly Edgar Linton and Isabella. The novel explores themes of love, revenge, social class, and the destructive power of unchecked passion. Wuthering Heights presents complex characters, most notably Heathcliff, who challenges conventional notions of heroism and romance. Against the backdrop of the wild moors, Bronte weaves a dark and haunting tale that continues to captivate readers.

SubQuestion No : 93

Q.93 Who is entranced by the neighbouring farmhouse named Wuthering Heights?

- Ans
- 1. Isabella
 - 2. Edgar Linton
 - 3. Catherine Earnshaw
 - 4. Mr. Lockwood

Question ID : 264330165271

Option 1 ID : 264330648171

Option 2 ID : 264330648172

Option 3 ID : 264330648173

Option 4 ID : 264330648174

Status : Answered

Chosen Option : 4

Comprehension:

Read the given passage and answer the questions that follow.

Wuthering Heights, penned by Emily Bronte, is a captivating novel set on the desolate moors of Yorkshire. The story revolves around the intense relationships and obsessions of its characters. The narrative begins with Mr. Lockwood, who rents Thrushcross Grange from the enigmatic Heathcliff. Intrigued by the neighbouring farmhouse, Wuthering Heights, Lockwood delves into the complex history of the Earnshaw and Linton families. The heart of the story focuses on the passionate love affair between Heathcliff and Catherine Earnshaw, which leads to betrayal and revenge. Heathcliff's thirst for vengeance drives the plot, inflicting suffering upon those who wronged him, particularly Edgar Linton and Isabella. The novel explores themes of love, revenge, social class, and the destructive power of unchecked passion. Wuthering Heights presents complex characters, most notably Heathcliff, who challenges conventional notions of heroism and romance. Against the backdrop of the wild moors, Bronte weaves a dark and haunting tale that continues to captivate readers.

SubQuestion No : 94

Q.94 Select the most appropriate synonym of the word 'conventional'.

- Ans
- 1. Abnormal
 - 2. Unusual
 - 3. Customary
 - 4. Contemporary

Question ID : 264330165273

Option 1 ID : 264330648179

Option 2 ID : 264330648182

Option 3 ID : 264330648180

Option 4 ID : 264330648181

Status : Answered

Chosen Option : 3

Comprehension:

Read the given passage and answer the questions that follow.

Wuthering Heights, penned by Emily Bronte, is a captivating novel set on the desolate moors of Yorkshire. The story revolves around the intense relationships and obsessions of its characters. The narrative begins with Mr. Lockwood, who rents Thrushcross Grange from the enigmatic Heathcliff. Intrigued by the neighbouring farmhouse, Wuthering Heights, Lockwood delves into the complex history of the Earnshaw and Linton families. The heart of the story focuses on the passionate love affair between Heathcliff and Catherine Earnshaw, which leads to betrayal and revenge. Heathcliff's thirst for vengeance drives the plot, inflicting suffering upon those who wronged him, particularly Edgar Linton and Isabella. The novel explores themes of love, revenge, social class, and the destructive power of unchecked passion. Wuthering Heights presents complex characters, most notably Heathcliff, who challenges conventional notions of heroism and romance. Against the backdrop of the wild moors, Bronte weaves a dark and haunting tale that continues to captivate readers.

SubQuestion No : 95

Q.95 Select the most appropriate ANTONYM of the word 'vengeance'.

- Ans
- 1. Compensation
 - 2. Custom
 - 3. Forgiveness
 - 4. Requit

Question ID : 264330165274

Option 1 ID : 264330648185

Option 2 ID : 264330648183

Option 3 ID : 264330648186

Option 4 ID : 264330648184

Status : Answered

Chosen Option : 3

Comprehension:

Read the given passage carefully and answer the questions that follows.

Where there is a will, there is a way, that is, if we are really determined to do a thing, however difficult it may be, however great obstacles in our path, we shall at last find a way of doing it. All difficulties, all hardships, all obstacles, however, insurmountable they may appear, melt before a determined will. A fierce desire, a strong determination, an iron will, will overcome all obstacles and triumph over all difficulties. A strong will is like a rushing torrent that sweeps away rocks and stones and trees in the path. Men who have 'towered high above their fellows' have been remarkable for their undaunted will.

SubQuestion No : 96

Q.96 Select a suitable title for the passage.

- Ans
- 1. Where There's A Will, There's A Way
 - 2. Birds of a Feather Flock Together
 - 3. Make a Mountain of a Molehill
 - 4. A Rolling Stone Gathers no Moss

Question ID : 264330169604

Option 1 ID : 264330665127

Option 2 ID : 264330665128

Option 3 ID : 264330665130

Option 4 ID : 264330665129

Status : Answered

Chosen Option : 1

Comprehension:

Read the given passage carefully and answer the questions that follows.

Where there is a will, there is a way, that is, if we are really determined to do a thing, however difficult it may be, however great obstacles in our path, we shall at last find a way of doing it. All difficulties, all hardships, all obstacles, however, insurmountable they may appear, melt before a determined will. A fierce desire, a strong determination, an iron will, will overcome all obstacles and triumph over all difficulties. A strong will is like a rushing torrent that sweeps away rocks and stones and trees in the path. Men who have 'towered high above their fellows' have been remarkable for their undaunted will.

SubQuestion No : 97**Q.97 Identify the structure of the passage.**

- Ans 1. Problem and solution
 2. Process
 3. Description
 4. Chronological

Question ID : 264330169606

Option 1 ID : 264330665136

Option 2 ID : 264330665137

Option 3 ID : 264330665138

Option 4 ID : 264330665135

Status : Answered

Chosen Option : 3

Comprehension:

Read the given passage carefully and answer the questions that follows.

Where there is a will, there is a way, that is, if we are really determined to do a thing, however difficult it may be, however great obstacles in our path, we shall at last find a way of doing it. All difficulties, all hardships, all obstacles, however, insurmountable they may appear, melt before a determined will. A fierce desire, a strong determination, an iron will, will overcome all obstacles and triumph over all difficulties. A strong will is like a rushing torrent that sweeps away rocks and stones and trees in the path. Men who have 'towered high above their fellows' have been remarkable for their undaunted will.

SubQuestion No : 98**Q.98 Identify the tone of the passage.**

- Ans 1. Informal
 2. Worried
 3. Humorous
 4. Encouraging

Question ID : 264330169607

Option 1 ID : 264330665141

Option 2 ID : 264330665142

Option 3 ID : 264330665139

Option 4 ID : 264330665140

Status : Answered

Chosen Option : 4

Comprehension:

Read the given passage carefully and answer the questions that follows.

Where there is a will, there is a way, that is, if we are really determined to do a thing, however difficult it may be, however great obstacles in our path, we shall at last find a way of doing it. All difficulties, all hardships, all obstacles, however, insurmountable they may appear, melt before a determined will. A fierce desire, a strong determination, an iron will, will overcome all obstacles and triumph over all difficulties. A strong will is like a rushing torrent that sweeps away rocks and stones and trees in the path. Men who have 'towered high above their fellows' have been remarkable for their undaunted will.

SubQuestion No : 99**Q.99 Identify the main theme of the passage.**

- Ans 1. The main theme of the passage is to have an ambition and a desire in life.
2. The main theme of the passage is trusting oneself.
3. The main theme of the passage is strong will. A person having strong will can achieve anything in life.
4. The main theme of the passage is to have a goal in life.

Question ID : 264330169605

Option 1 ID : 264330665134

Option 2 ID : 264330665132

Option 3 ID : 264330665131

Option 4 ID : 264330665133

Status : Answered

Chosen Option : 3

Comprehension:

Read the given passage carefully and answer the questions that follows.

Where there is a will, there is a way, that is, if we are really determined to do a thing, however difficult it may be, however great obstacles in our path, we shall at last find a way of doing it. All difficulties, all hardships, all obstacles, however, insurmountable they may appear, melt before a determined will. A fierce desire, a strong determination, an iron will, will overcome all obstacles and triumph over all difficulties. A strong will is like a rushing torrent that sweeps away rocks and stones and trees in the path. Men who have 'towered high above their fellows' have been remarkable for their undaunted will.

SubQuestion No : 100**Q.100 Select the most appropriate ANTONYM for the given word.****Undaunted**

- Ans 1. Feisty
2. Indomitable
3. Cowardly
4. Impetuous

Question ID : 264330169608

Option 1 ID : 264330665143

Option 2 ID : 264330665144

Option 3 ID : 264330665145

Option 4 ID : 264330665146

Status : Answered

Chosen Option : 4